



LOW-VOLTAGE 24-BIT BUS EXCHANGE SWITCH

IDT74CBTLV16212

FEATURES:

- 5Ω A/B bi-directional switch
- Isolation Under Power-Off Conditions
- Over-voltage tolerant
- Latch-up performance exceeds 100mA
- Vcc = 2.3V - 3.6V, normal range
- ESD >2000V per MIL-STD-883, Method 3015; >200V using machine model (C = 200pF, R = 0)
- Available in TSSOP package

APPLICATIONS:

- 3.3V High Speed Bus Switching and Bus Isolation

DESCRIPTION:

The CBTLV16212 provides a set of 24 high-speed switches for bus exchanging and switching. The device has low ON resistance, resulting in under 250ps propagation delay through the switch. The CBTLV16212 operates as a single 24-bit bus switch or as a 12-bit bus exchanger, which provides data exchanging between the four signal ports through the data select (S0-S2) pins.

The CBTLV16212 has the break-before-make feature, which allows zero current when switching between ports B1 and B2.

FUNCTIONAL BLOCK DIAGRAM

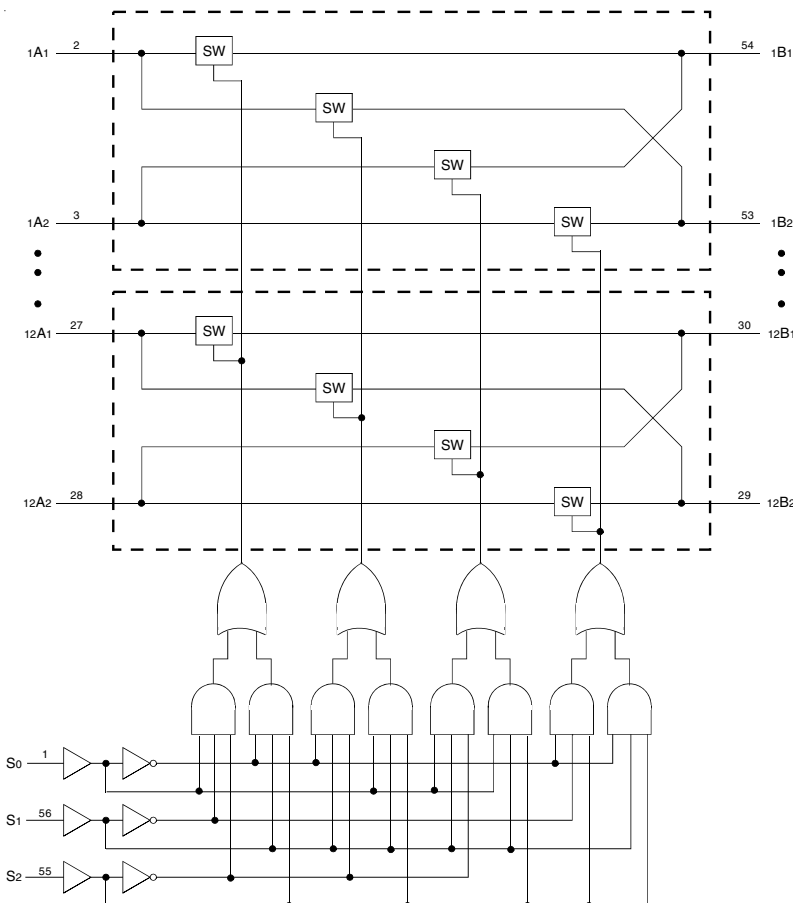

SIMPLIFIED SCHEMATIC, EACH SWITCH

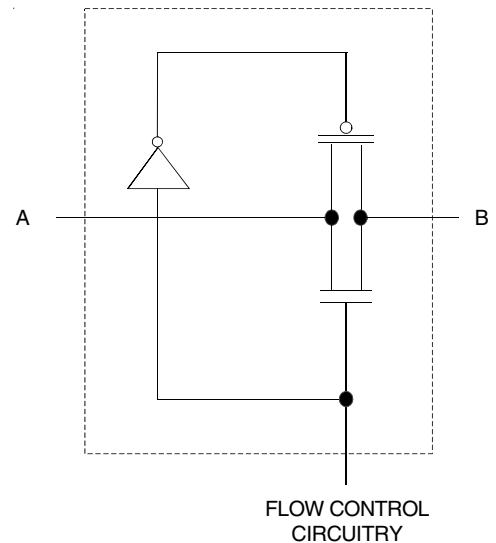

The IDT logo is a registered trademark of Integrated Device Technology, Inc.

INDUSTRIAL TEMPERATURE RANGE

DECEMBER 2014

PIN CONFIGURATION

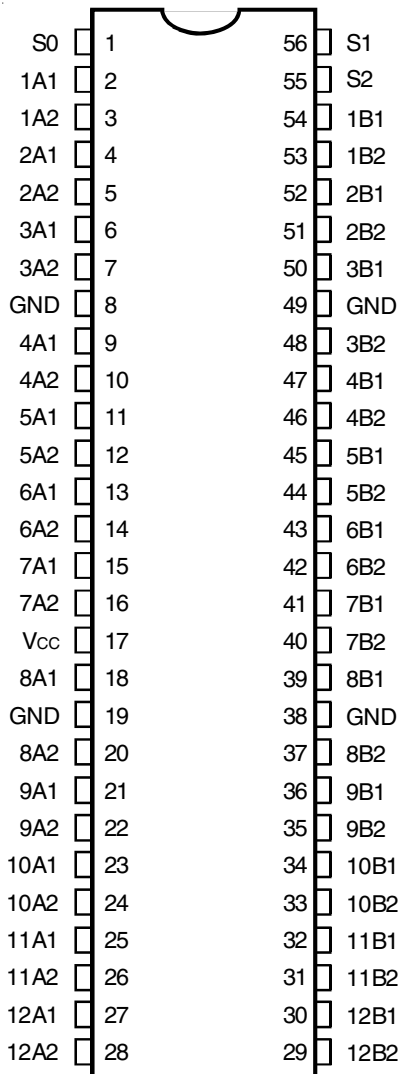

TSSOP
TOP VIEW

ABSOLUTE MAXIMUM RATINGS⁽¹⁾

Symbol	Description	Max.	Unit
V _{CC}	Supply Voltage Range	-0.5 to 4.6	V
V _I	Input Voltage Range	-0.5 to 4.6	V
	Continuous Channel Current	128	mA
I _{IK}	Input Clamp Current, V _{I/O} < 0	-50	mA
T _{STG}	Storage Temperature Range	-65 to +150	°C

NOTE:

- Stresses greater than those listed under ABSOLUTE MAXIMUM RATINGS may cause permanent damage to the device. This is a stress rating only and functional operation of the device at these or any other conditions above those indicated in the operational sections of this specification is not implied. Exposure to absolute maximum rating conditions for extended periods may affect reliability.

PIN DESCRIPTION

Pin Names	Description
S _x	Data Select
xA _x	Port A Inputs or Outputs
xB _x	Port B Inputs or Outputs

FUNCTION TABLE⁽¹⁾

Inputs			Inputs/Outputs		Operation
S ₂	S ₁	S ₀	A ₁	A ₂	
L	L	L	Z	Z	Disconnect
L	L	H	B ₁	Z	A ₁ port = B ₁ port
L	H	L	B ₂	Z	A ₁ port = B ₂ port
L	H	H	Z	B ₁	A ₂ port = B ₁ port
H	L	L	Z	B ₂	A ₂ port = B ₂ port
H	L	H	Z	Z	Disconnect
H	H	L	B ₁	B ₂	A ₁ port = B ₁ port A ₂ port = B ₂ port
H	H	H	B ₂	B ₁	A ₁ port = B ₂ port A ₂ port = B ₁ port

NOTE:

- H = HIGH Voltage Level
L = LOW Voltage Level
Z = High-Impedance

OPERATING CHARACTERISTICS⁽¹⁾

Symbol	Parameter	Test Conditions	Min.	Max.	Unit
V _{CC}	Supply Voltage		2.3	3.6	V
V _{IH}	High-Level Control Input Voltage	V _{CC} = 2.3V to 2.7V	1.7	—	V
		V _{CC} = 2.7V to 3.6V	2	—	
V _{IL}	Low-Level Control Input Voltage	V _{CC} = 2.3V to 2.7V	—	0.7	V
		V _{CC} = 2.7V to 3.6V	—	0.8	
T _A	Operating Free-Air Temperature		-40	+85	°C

NOTE:

- All unused control inputs of the device must be held at V_{CC} or GND to ensure proper device operation.

DC ELECTRICAL CHARACTERISTICS OVER OPERATING RANGE

Following Conditions Apply Unless Otherwise Specified:

Operating Condition: TA = -40°C to +85°C

Symbol	Parameter	Test Conditions	Min.	Typ. ⁽¹⁾	Max.	Unit	
V _{IK}	Control Inputs, Data I/O	V _{CC} = 3V, I _I = -18mA	—	—	-1.2	V	
I _I	Control Inputs	V _{CC} = 3.6V, V _I = V _{CC} or GND	—	—	±1	μA	
I _{OZ}	Data I/O	V _{CC} = 3.6V, V _O = 0V or 3.6V switch disabled	—	—	5	μA	
I _{OFF}		V _{CC} = 0V, V _I or V _O = 0V or 3.6V	—	—	10	μA	
I _{CC}		V _{CC} = 3.6V, I _O = 0, V _I = V _{CC} or GND	—	—	10	μA	
ΔI _{CC} ⁽²⁾	Control Inputs	V _{CC} = 3.6V, one input at 3V, other inputs at V _{CC} or GND	—	—	300	μA	
C _I	Control Inputs	V _I = 3V or 0	—	5	—	pF	
C _{I(OFF)}		V _O = 3V or 0 (switch off)	—	13.5	—	pF	
R _{ON} ⁽³⁾	Max. at V _{CC} = 2.3V Typ. at V _{CC} = 2.5V	V _I = 0	I _O = 64mA	—	5	8	Ω
			I _O = 24mA	—	5	8	
	V _{CC} = 3V	V _I = 1.7V	I _O = 15mA	—	27	40	
			V _I = 0	I _O = 64mA	—	5	
		V _I = 2.4V		I _O = 24mA	—	5	
			V _I = 2.4V	I _O = 15mA	—	10	

NOTES:

1. Typical values are at 3.3V, +25°C ambient.
2. The increase in supply current is attributable to each input that is at the specified voltage level rather than V_{CC} or GND.
3. This is measured by the voltage drop between the A and B terminals at the indicated current through the switch.

SWITCHING CHARACTERISTICS

Symbol	Parameter	V _{CC} = 2.5V ± 0.2V		V _{CC} = 3.3V ± 0.3V		Unit
		Min.	Max.	Min.	Max.	
t _{PD} ⁽¹⁾	Propagation Delay A to B or B to A	—	0.15	—	0.25	ns
t _{PD}	Propagation Delay S to A or B	3	11.1	3	8.8	ns
t _{EN}	Output Enable Time S to A or B	3	10.9	3	8.6	ns
t _{DIS}	Output Disable Time S to A or B	1	8.7	2	8.8	ns

NOTE:

1. The propagation delay is the calculated RC time constant of the typical on-state resistance of the switch and the specified load capacitance when driven by an ideal voltage source (zero output impedance).

TEST CIRCUITS AND WAVEFORMS

TEST CONDITIONS

Symbol	V _{CC} ⁽¹⁾ =3.3V±0.3V	V _{CC} ⁽²⁾ =2.5V±0.2V	Unit
V _{LOAD}	6	2 x V _{CC}	V
V _{IH}	3	V _{CC}	V
V _T	1.5	V _{CC} / 2	V
V _{LZ}	300	150	mV
V _{HZ}	300	150	mV
C _L	50	30	pF

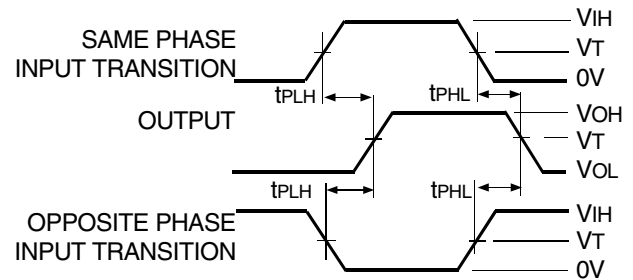

Propagation Delay

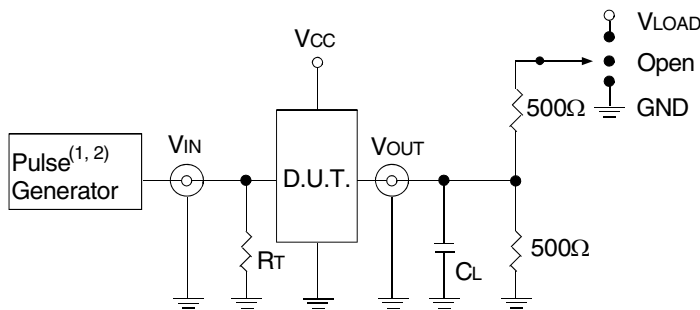

Test Circuits for All Outputs

DEFINITIONS:

C_L = Load capacitance: includes jig and probe capacitance.
 R_T = Termination resistance: should be equal to Z_{OUT} of the Pulse Generator.

NOTES:

1. Pulse Generator for All Pulses: Rate ≤ 10MHz; t_r ≤ 2.5ns; t_f ≤ 2.5ns.
2. Pulse Generator for All Pulses: Rate ≤ 10MHz; t_r ≤ 2ns; t_f ≤ 2ns.

SWITCH POSITION

Test	Switch
t _{PLZ} /t _{PZL}	V _{LOAD}
t _{PHZ} /t _{PZH}	GND
t _{PD}	Open

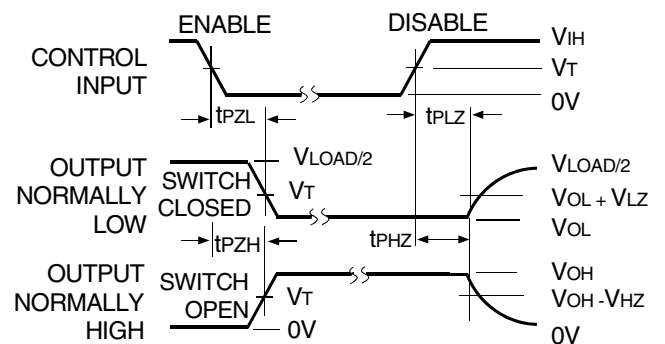

NOTE:

1. Diagram shown for input Control Enable-LOW and input Control Disable-HIGH.

Enable and Disable Times

ORDERING INFORMATION

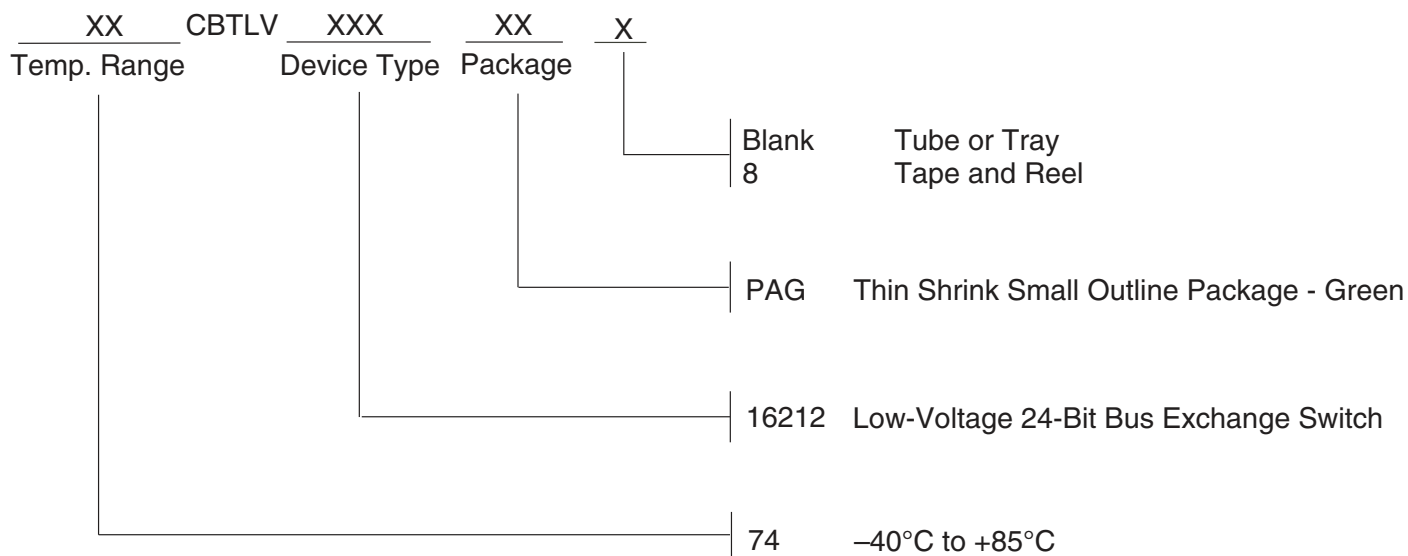

Datasheet Document History

12/04/2014 Pg. 5 Updated the ordering information by removing the "IDT" notation, non RoHS part and by adding Tape and Reel information.



CORPORATE HEADQUARTERS
6024 Silver Creek Valley Road
San Jose, CA 95138

for SALES:
800-345-7015 or 408-284-8200
fax: 408-284-2775
www.idt.com

for Tech Support:
logichelp@idt.com