

General Description

The AOZ1353DI is a current-limited load switch targeting applications that require comprehensive protections. The input operating voltage range is between 3.4V and 5.5V. The output terminal is rated 28V absolute maximum. The internal current-limiting circuit protects the supply from large load current. The current limit level is set with an external resistor. The soft-start circuit controls inrush current due to highly capacitive loads. The soft-start time can be optionally adjusted with an external capacitor. The device features very low quiescent current of 80µA. The supply current reduces to less than 1µA in shut- down. It also has under-voltage lockout (UVLO), over- voltage protection (OVP) and thermal shutdown protection.

The AOZ1353DI has True Reverse-Current Blocking (TRCB) protection to avoid undesired reverse-current from VOUT to VIN.

The device features fast recovery to turn on power switch once reverse current blocking protection is de-activated.

The AOZ1353DI is available in 3mm x 3mm DFN-12L package.

Features

- 28V voltage rating on VOUT pin
- 3.4V to 5.5V operating input voltage
- 3.5A current capability
- Typical RON: 40mΩ
- Programmable current limit
- True Reverse-Current Blocking (TRCB)
- Fast recovery from TRCB
- Adjustable soft-start
- 80µA quiescent current
- Over-voltage protection
- Input under-voltage lockout
- Thermal shutdown protection
- ±4kV HBM rating
- ±1kV CDM Rating
- DFN3x3-12L package
- IEC 62368-1: 2018 (3rd edition) Certificate Number US-39616-UL

Applications

- USB PD power source switch
- Smart phone and tablet
- Notebook, ultrabook and desktop
- Portable devices



Typical Applications

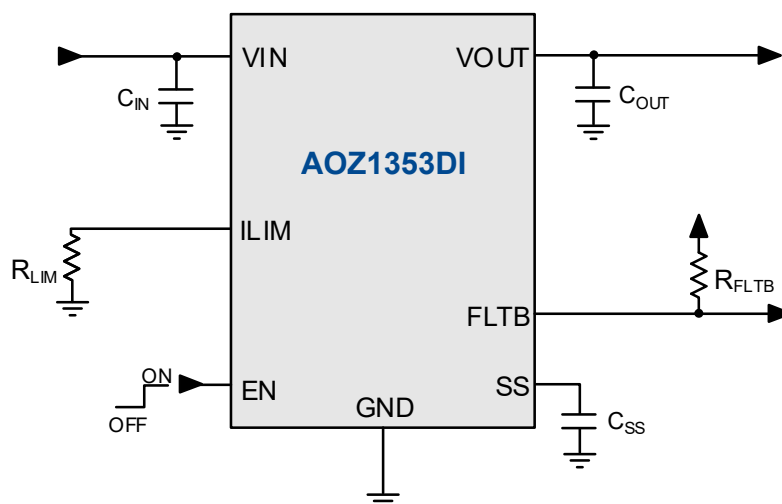

Ordering Information

Part Number	Fault Recovery	Short Circuit Protection Response	Package	Environmental
AOZ1353DI-01	Auto-Restart	Current Limit	DFN3x3-12L	RoHS
AOZ1353DI-02	Latch-Off	Current Limit	DFN3x3-12L	RoHS
AOZ1353DI-03	Auto-Restart	Fast Shutdown	DFN3x3-12L	RoHS
AOZ1353DI-04	Latch-Off	Fast Shutdown	DFN3x3-12L	RoHS



AOS Green Products use reduced levels of Halogens, and are also RoHS compliant. Please visit www.aosmd.com/media/AOSGreenPolicy.pdf for additional information.

Pin Configuration

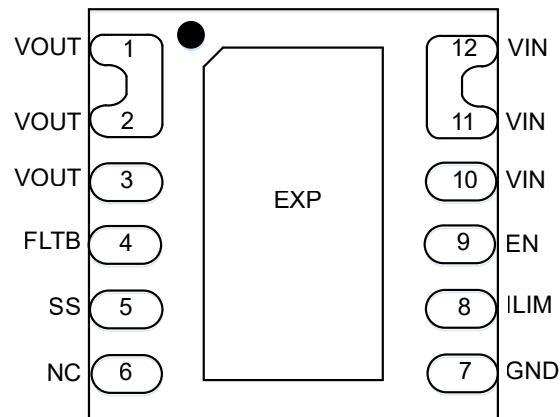

DFN3x3-12L
(Top Transparent View)

Pin Description

Pin Number	Pin Name	Pin Function
1, 2, 3	VOUT	Power output. Connect to adaptor. Pin 3 is internally connected to Pin 1 and Pin 2.
4	FLT B	Fault indicator, open-drain output, active-low when fault condition occurs.
5	SS	Soft-start pin. Connect a capacitor C_{SS} from SS to GND to set the soft-start time or short to GND for fixed-time soft-start.
6	NC	Not connected internally. Can leave it floated or connect to GND.
7	GND	Ground
8	ILIM	Current limit set pin. Connect a 1% resistor R_{LIM} from ILIM to GND to set the current limit threshold.
9	EN	Enable input. Active high.
10, 11, 12	VIN	Supply input. Connected to internal power regulator. Pin 10 is internally connected to Pin 11 and Pin 12.
EXP	EXP	Exposed pad. Connect to GND.

Absolute Maximum Ratings

Exceeding the Absolute Maximum ratings may damage the device.

Parameter	Rating
V _{OUT} to GND	-0.3V to +28V
V _{IN} , EN, ILIM, SS, FLTB to GND	-0.3V to +6V
Junction Temperature (T _J)	+150°C
Storage Temperature (T _S)	-65°C to +150°C
ESD Rating HBM/CDM	±4kV / ±1kV

Recommended Operating Conditions

The device is not guaranteed to operate beyond the Maximum Recommended Operating Conditions.

Parameter	Rating
V _{IN} to GND	3.4V to 5.5V
EN, FLTB to GND	0V to 5.5V
Switch Current (ISW)	0A to 3.5A
Ambient Temperature (T _A)	-40°C to +85°C
Package Thermal Resistance	50°C/W

Electrical Characteristics

T_A = 25°C, V_{IN} = 5V, EN = 5V, SS is shorted to GND unless otherwise specified.

Symbol	Parameter	Conditions	Min	Typ	Max	Units
General						
V _{IN}	Input Supply Voltage		3.4		5.5	V
V _{UVLO_R}	Under-voltage Lockout Threshold	V _{IN} rising	3	3.25	3.35	V
V _{UVLO_HYS}	Under-voltage Lockout Hysteresis	V _{IN} falling		150		mV
I _{IN_ON}	Input Quiescent Current	I _{OUT} = 0A AOZ1353DI-01 and AOZ1353DI-02		80		μA
		I _{OUT} = 0A AOZ1353DI-03 and AOZ1353DI-04		125		
I _{IN_OFF}	Input Shutdown Current	I _{OUT} = 0A, EN = 0V AOZ1353DI-01 and AOZ1353DI-02		0.1		μA
		I _{OUT} = 0A, EN = 0V AOZ1353DI-03 and AOZ1353DI-04		6		
R _{ON}	Switch On Resistance	V _{IN} = 5V, I _{OUT} = 1A		40		mΩ
V _{EN_H}	Enable Input Logic High Threshold	EN rising	1.4			V
V _{EN_L}	Enable Input Logic Low Threshold	EN falling			0.4	V
I _{EN_BIAS}	Enable Input Bias Current	EN = 1.8V		1	1.5	μA
V _{FLTB_LO}	FLTB Pull-down Voltage	I _{SINK} = 3mA			0.3	V
Over-Voltage Protection						
V _{OVLO_R}	Over-voltage Lockout Threshold	V _{IN} rising	5.5	5.75	6	V
V _{OVLO_F}		V _{IN} falling. AOZ1353DI-01 and AOZ1353DI-03 only.		5.5		
V _{OVLO_HYS}	Over-voltage Lockout Hysteresis	V _{IN} Falling. AOZ1353DI-01 and AOZ1353DI-03 only.		250		mV
t _{DELAY_OVP}	OVP Turn-Off Delay			2		μs

Electrical Characteristics

$T_A = 25^\circ\text{C}$, $V_{IN} = 5\text{V}$, $EN = 5\text{V}$, SS is shorted to GND unless otherwise specified.

Symbol	Parameter	Conditions	Min	Typ	Max	Units
Over-Current Protection						
I_{LIM}	Current Limit Threshold	$V_{OUT} = 5\text{V}$, $R_{LIM} = 4.02\text{k}\Omega$	3.08	3.5	3.92	A
		$V_{OUT} = 5\text{V}$, $R_{LIM} = 14.3\text{k}\Omega$	0.9	1	1.1	
		$V_{OUT} = 5\text{V}$, $R_{LIM} = 29.4\text{k}\Omega$	0.45	0.5	0.55	
$t_{OCP_FLT B}$	Over-Current Flag Delay	From $I_{OOUT} \geq I_{LIM}$ to FLT B pulled low		12		ms
True Reverse-Current Blocking						
V_{T_TRCB}	TRCB Protection Trip Point	$V_{OUT} > V_{IN}$, V_{OUT} rising		60		mV
V_{R_TRCB}	TRCB Protection Release Trip Point	$V_{OUT} < V_{IN}$, V_{OUT} falling		70		mV
V_{TRCB_HYS}	TRCB Hysteresis	$V_{T_TRCB} + V_{R_TRCB}$		130		mV
t_{TRCB}	TRCB Response Time			2		μs
Thermal Shutdown Protection						
T_{SD}	Thermal Shutdown Threshold	Temperature rising.		140		$^\circ\text{C}$
T_{SD_HYS}	Thermal Shutdown Hysteresis	Temperature falling AOZ1353DI-01 and AOZ1353DI-03 Only		20		
Dynamic Timing Characteristics						
t_{D_ON}	Turn-On Delay Time (From $EN = 50\%$ to $V_{OUT} = 0.5\text{V}$)	$V_{IN} = 5\text{V}$, $R_L = 100\Omega$, $C_{OUT} = 1\mu\text{F}$, $C_{SS} = 1\text{nF}$, $R_{LIM} = 14.3\text{k}\Omega$		2.1		ms
t_{ON}	Turn-On Rise Time (V_{OUT} from 0.5V to 4.5V)	$V_{IN} = 5\text{V}$, $R_L = 100\Omega$, $C_{OUT} = 1\mu\text{F}$, SS Pin grounded, $R_{LIM} = 14.3\text{k}\Omega$		3.4		ms

Functional Block Diagram

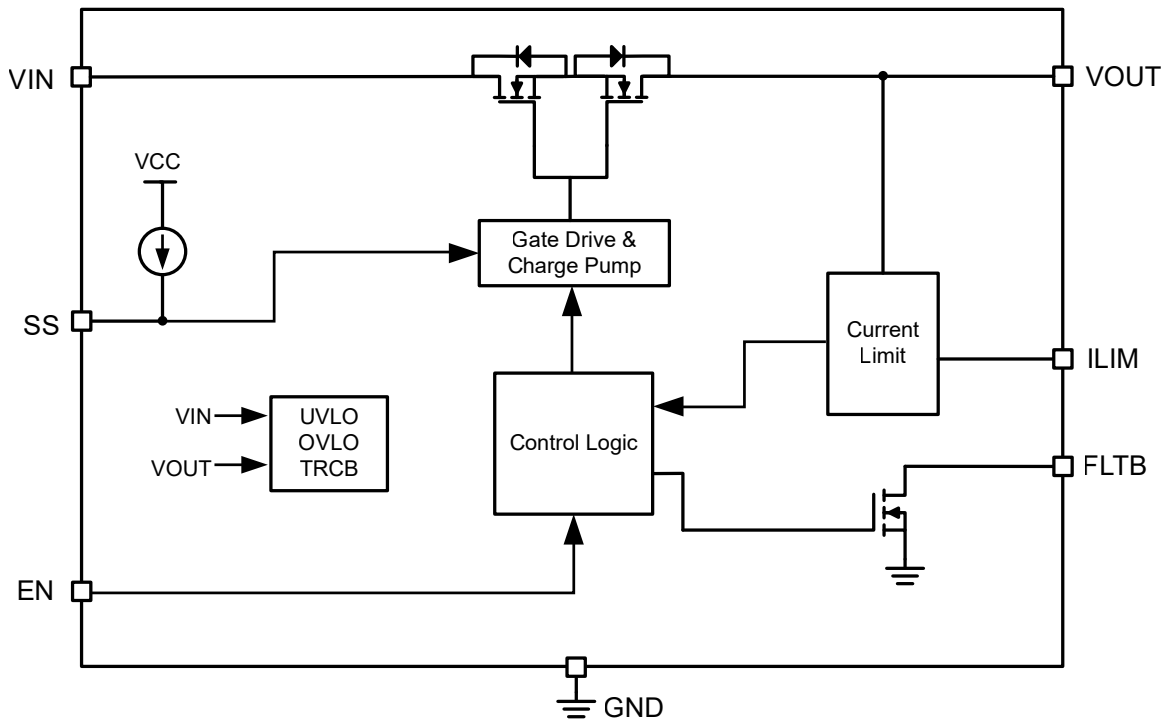

Timing Diagrams

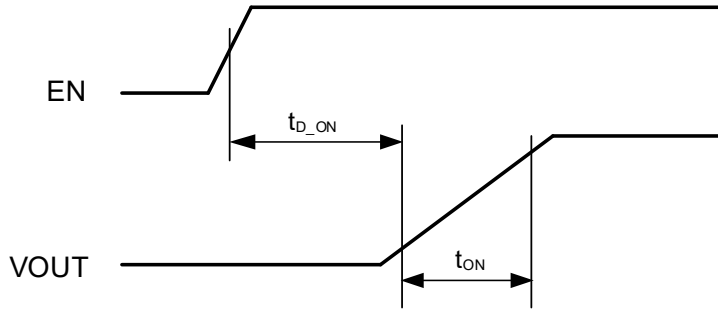

Figure 1. Turn-on Delay and Turn-on Time

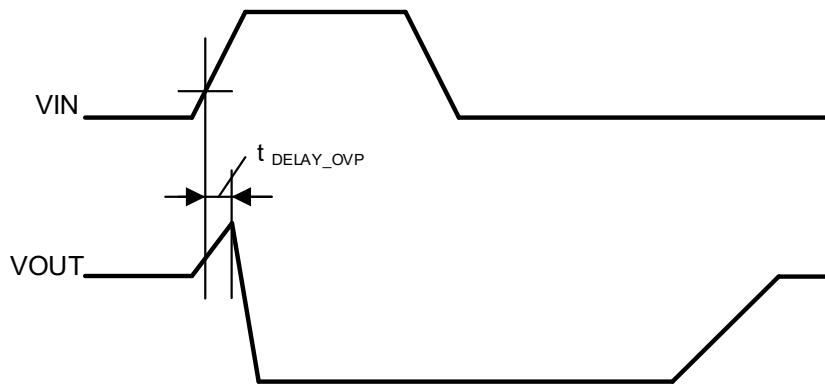
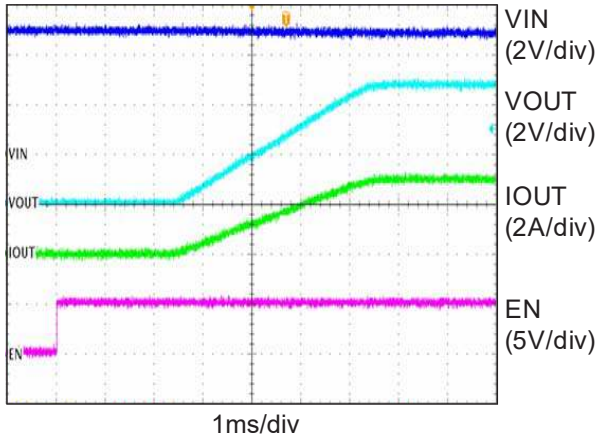

Figure 2. Over-Voltage Protection Delay and Recovery

Typical Characteristics

$T_A = 25\text{ }^\circ\text{C}$, $V_{IN} = 5\text{ V}$, $C_{OUT} = 20\mu\text{F}$, $R_{LIM} = 4.02\text{ k}\Omega$, SS pin shorted to GND unless otherwise specified.

Startup by EN
($R_{Load} = 1.6\ \Omega$)



Shutdown by EN
($R_{Load} = 1.6\ \Omega$)

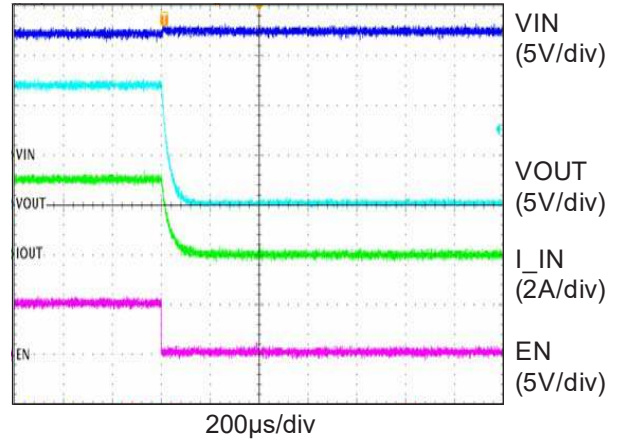

Startup by VIN
($R_{Load} = 1.6\ \Omega$)

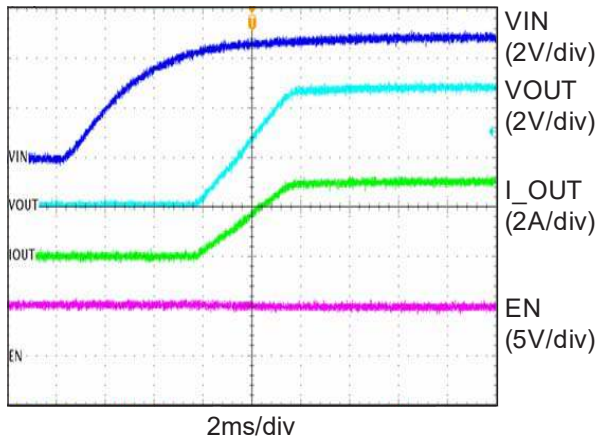

Shutdown by VIN
($R_{Load} = 1.6\ \Omega$)

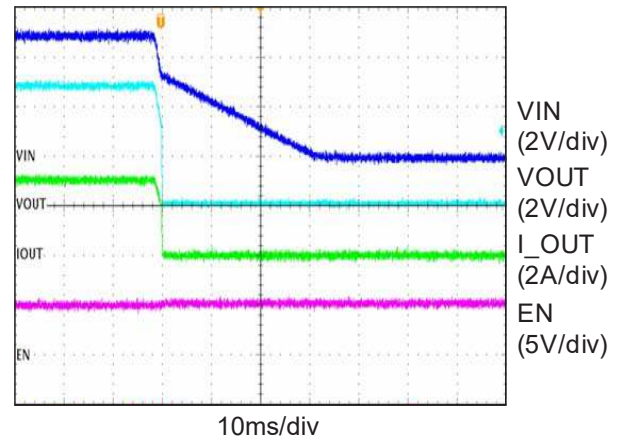

Input OVP and Recovery ($R_{Load} = 1\text{ k}\Omega$,
AOZ1353DI-01 and AOZ1353DI-03)

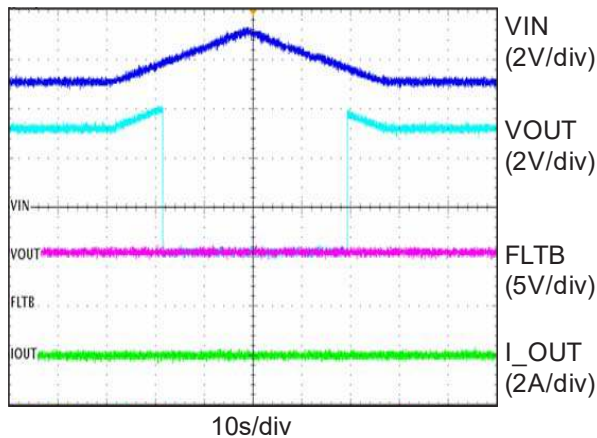

Over-Current Protection ($R_{Load} = 1\text{ k}\Omega$,
AOZ1353DI-02 and AOZ1353DI-04)

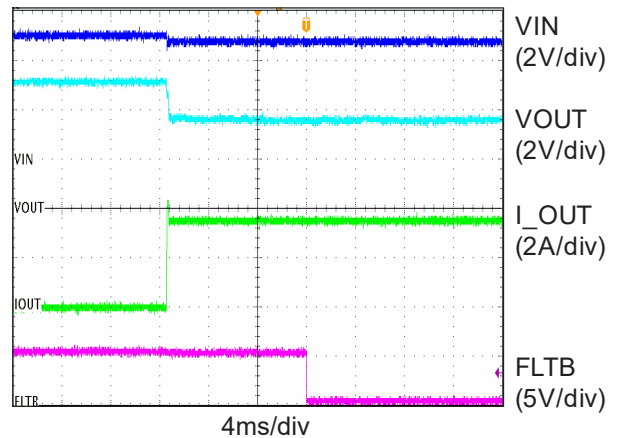

Typical Characteristics

$T_A = 25\text{ }^\circ\text{C}$, $V_{IN} = 5\text{ V}$, $C_{OUT} = 20\mu\text{F}$, $R_{LIM} = 4.02\text{k}\Omega$, SS pin shorted to GND unless otherwise specified.

Output Short and Thermal Shutdown AOZ1353DI-01 and AOZ1353DI-03

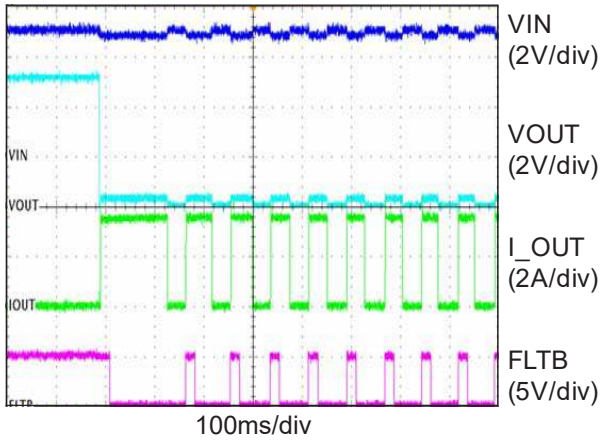

Typical Characteristics

$T_A = 25^\circ\text{C}$, $V_{IN} = 5\text{V}$ unless otherwise specified.

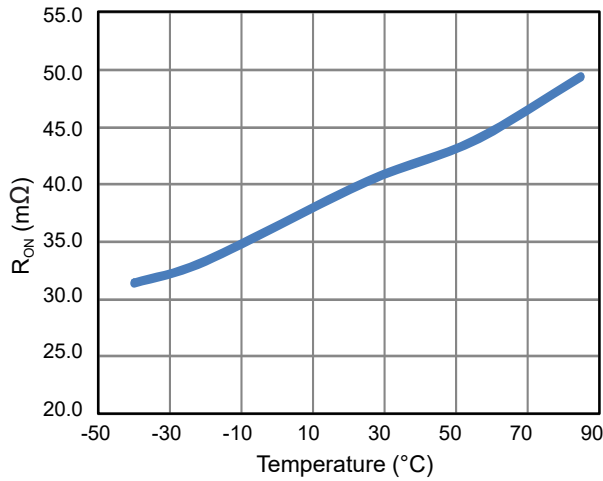

Figure 3. R_{ON} vs. Temperature

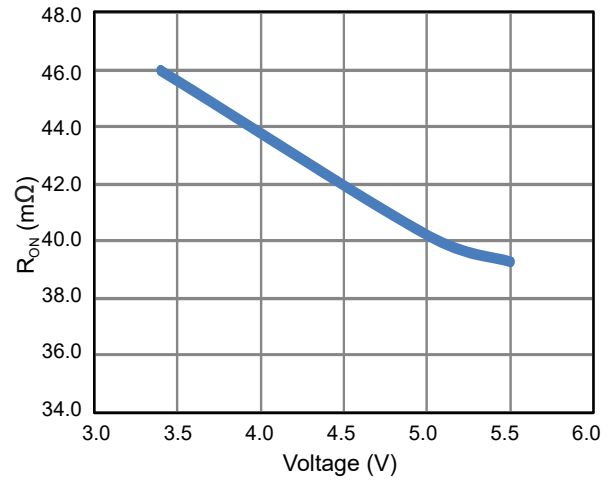

Figure 4. R_{ON} vs. Input Voltage

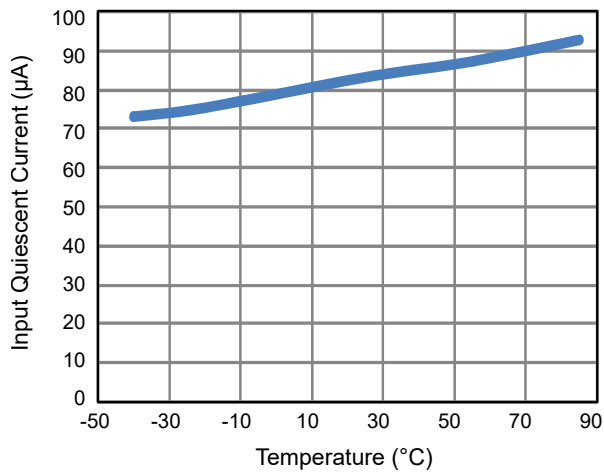

Figure 5. Input Quiescent Current vs. Temperature

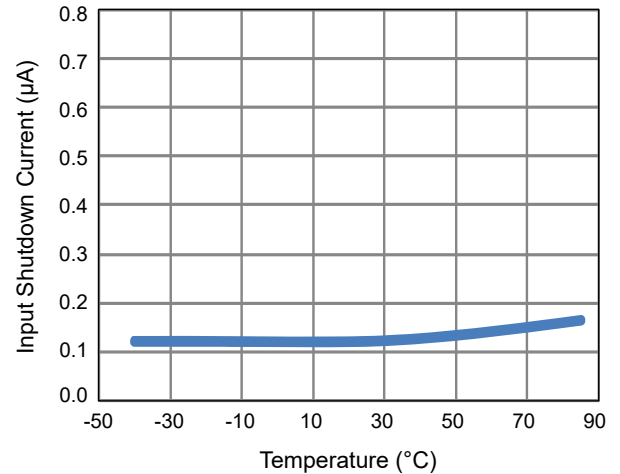

Figure 6. Input Shutdown Current vs. Temperature

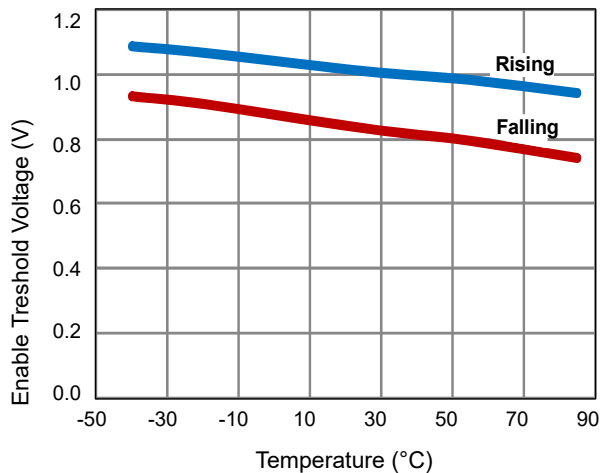

Figure 7. EN Threshold vs. Temperature

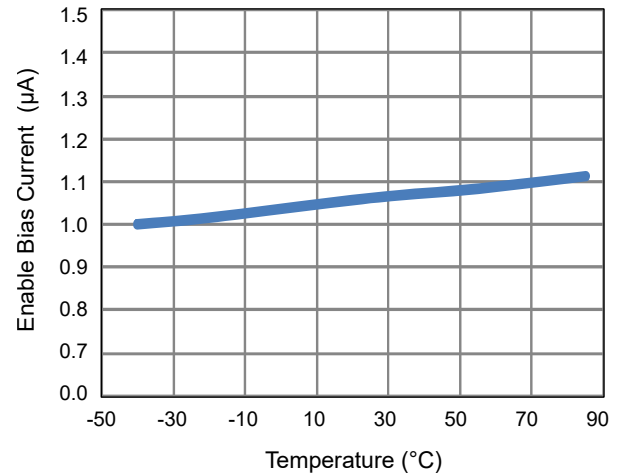

Figure 8. EN Bias Current vs. Temperature

Typical Characteristics

$T_A = 25\text{ }^\circ\text{C}$, $T_A = 25\text{ }^\circ\text{C}$, $V_{IN} = 5\text{V}$ unless otherwise specified.

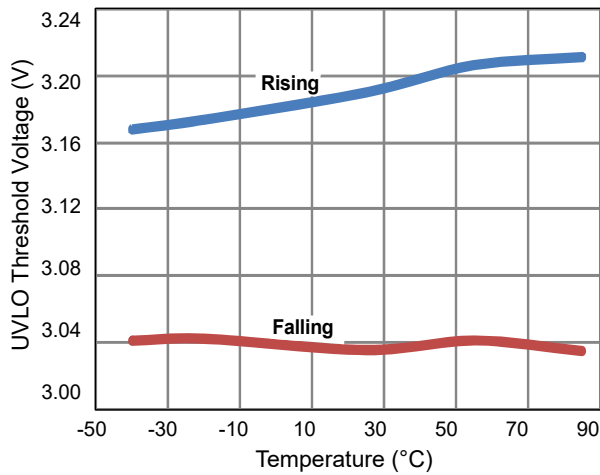

Figure 9. UVLO Threshold vs. Temperature

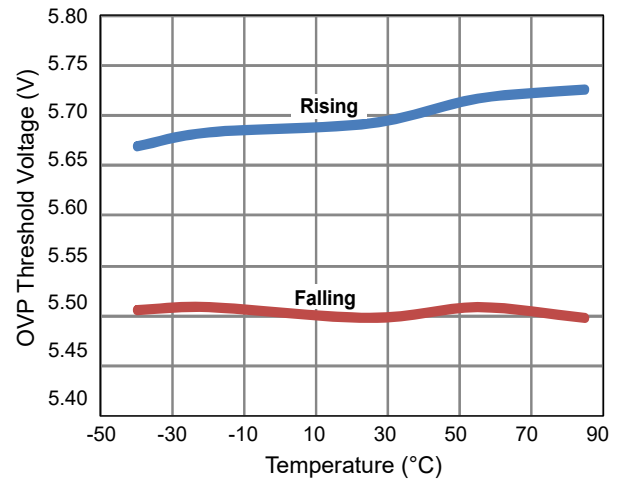

Figure 10. OVP Threshold vs. Temperature

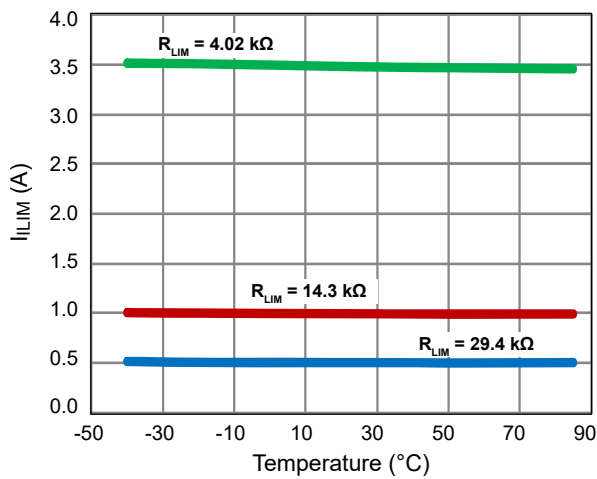

Figure 11. Current Limit Threshold vs. Temperature

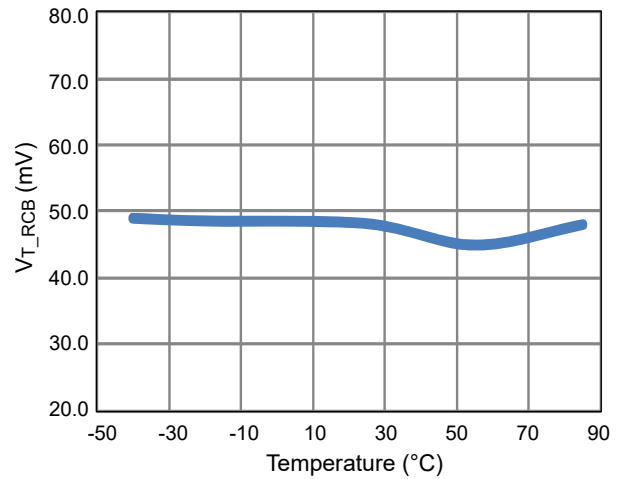

Figure 12. RCB Threshold (Rising) vs. Temperature

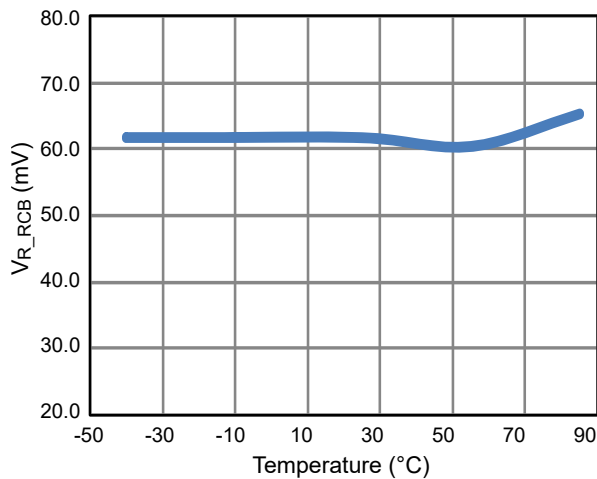

Figure 13. RCB Threshold (Falling) vs. Temperature

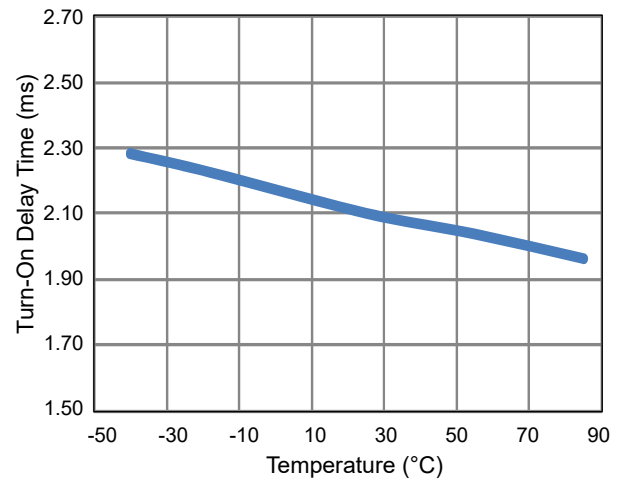

Figure 14. Turn-On Delay vs. Temperature

Typical Characteristics

$T_A = 25\text{ }^\circ\text{C}$, $V_{IN} = 5\text{V}$ unless otherwise specified.

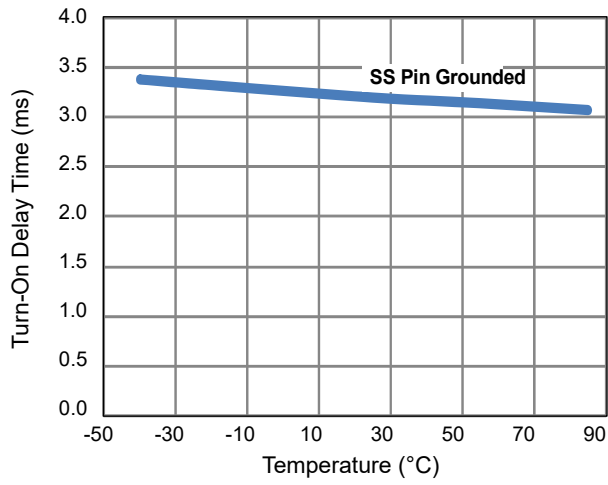

Figure 15. Turn-On Time vs. Temperature

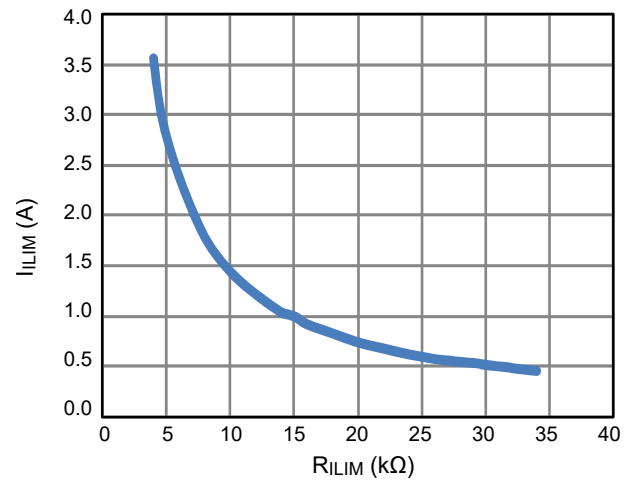

Figure 16. Current Limit vs. R_{LIM}

Functional Description

The AOZ1353DI is a current limited power switch with over-voltage, over-current, reverse-current and thermal shutdown protections. The VOUT pin is rated 28V. The operating input voltage ranges from 3.4V to 5.5V. The switch current is rated up to 3.5A.

The device has true reverse-current blocking features that will prevent undesired current flow from output to its input in either enabled or disabled state.

Enable

The EN pin is the ON/OFF control for the power switch. The device is enabled when EN pin is high and not in under-voltage lockout state. The EN pin must be driven to a logic high or logic low state to guarantee operation. While disabled, the AOZ1353DI draws less than 1 μ A from supply.

For AOZ1353DI-02 and AOZ1353DI-04, toggle EN pin to restart the device and clear fault flag after device latches off due to fault.

Input Under-Voltage Lockout (UVLO)

The under-voltage lockout (UVLO) circuit monitors the input voltage. The power switch is only allowed to turn on when input voltage is higher than UVLO threshold. Otherwise the switch is off.

Over-Voltage Protection (OVP)

The voltages at VIN terminal is constantly monitored once the device is enabled. In case input voltage exceeds the over-voltage lockout threshold (V_{OVLO_R}), the power switch is either turned off immediately or kept off, depending on its initial state. AOZ1353DI-01 and AOZ1353DI-03 can restart when VIN drops below V_{OVLO_F} .

Programmable Current Limit and Over-Current Protection (OCP)

The AOZ1353DI implemented current limit to ensure that the current through the switch does not exceed current limit threshold set by the external resistor RLIM.

The current limit threshold can be calculated using the equation below:

$$I_{LIM} = 14300/R_{LIM} \text{ (A)}$$

For example, for 1A current limit threshold, a 14.3k Ω RLIM resistor should be selected. 1% resistor is recommended for R_{LIM} .

AOZ1353DI continuously limits the output current when output is overloaded, Under current-limiting, FLT B is pulled low after delay ($t_{OCP_FLT B}$). Severe overload causes power dissipation and die temperature to increase and may trigger thermal shutdown.

Short Circuit Protection (SCP)

AOZ1353DI offers protection against output short circuit. In case of AOZ1353DI-01 and AOZ1353DI-02, when a hard short occurs while enabled, there will be a sudden increase in output current that can cause the input to drop momentarily before the part enters current limit. The device will remain in current limit indefinitely until the device is disabled or enters thermal shutdown.

In contrast, AOZ1353DI-03 and AOZ1353DI-04 have fast SCP comparator that will immediately shut down the pass device if $(V_{IN} - V_{OUT}) < 450\text{mV}$. AOZ1353DI-03 will restart the soft start after 3ms to resume normal operation. If the short stills persists the device will enter current limit until disabled or enters thermal shutdown.

True Reverse-Current Blocking Protection (TRCB)

True reverse-current blocking prevents undesired current flow from output to input when power switch is in either on or off state. When device is enabled, power switch is quickly turned off whenever output voltage is higher than input voltage. The power switch is turned on again when output voltage falls below input by 70mV.

Once RCB event is removed, power switch turns on again quickly. The recovery time is less than 100 μ s.

Thermal Shutdown Protection

Thermal shutdown protects device from excessive temperature. The power switch is turned off when the die temperature reaches thermal shutdown threshold of 140 $^{\circ}$ C. There is a 20 $^{\circ}$ C hysteresis. For AOZ1353DI-01 and AOZ1353DI-03 power switch is allowed to turn on again if die temperature drops below approximately 120 $^{\circ}$ C.

Soft Start

The AOZ1353DI has soft-start circuitry to limit in-rush current due to large capacitive load. By default the turn-on time is 3.4ms when SS pin is connected to GND.

Fast turn-on time can be set by adding an external capacitor CSS between SS pin and ground. The capacitor value can be selected using Table 1.

Table 1. Turn-On Time vs SS Capacitor Value

C _{SS} (nF)	Turn-On Time (ms)
1	0.3
1.2	0.4
2.2	0.8
3.3	1.2
4.7	1.7
5.6	1.9
6.8	2.4
8.2	2.8
10	3.2
12	3.4
SS pin short to GND	3.4

Startup

The device is enabled when $EN \geq V_{EN_H}$ and input voltage is above UVLO threshold. The device first checks if any fault condition exists. When no fault exists, the power switch is turned on and the output is then ramped up. Power switch is kept off if fault condition was detected.

Fault Reporting

AOZ1353DI protects itself and load from the following fault condition: over-voltage, over-current, reverse-current, and over-temperature.

The FLTB pin is an open drain output. It is asserted low when either an over-current, or over-temperature condition occurs. The FLTB pin becomes high impedance when the fault conditions are removed. A pull-up resistor (R_{FLTB}) must be connected between FLTB to 5V to provide a logic signal.

When thermal shutdown is activated, FLTB is pulled low immediately to report fault condition to host. FLTB is pulled high once fault is removed.

In case of output overload, FLTB pin is pulled low about 12ms (t_{OCP_FLTB}) after device is in current-limiting. For AOZ1353DI-02 and AOZ1353DI-04 power switch is then turned off after another 12ms.

There is no fault reporting for UVLO, OVP and TRCB event.

Auto-restart or Latch-off

AOZ1353DI-01 and AOZ1353DI-03 (auto-restart version): The device will try to restart 24ms after the power switch is turned off and when OVP or thermal shutdown fault is removed.

Power switch is turned on immediately after a TRCB event is removed.

AOZ1353DI-02 and AOZ1353DI-04 (latch-off version): The device keeps off even after the fault condition is removed. Power switch can only be turned on again by either toggle EN pin or recycle the input supply.

Input Capacitor Selection

The input capacitor prevents large voltage transients from appearing at the input, and provides the instantaneous current needed each time the switch turns on to charge output capacitors and to limit input voltage drop. It is also to prevent high-frequency noise on the power line from passing through to the output. The input capacitor should be located as close to the pin as possible. A minimum of 10 μ F ceramic capacitor should be used. However, higher capacitor value is strongly recommended to further reduce the transient voltage drop at the input.

Output Capacitor Selection

This bulk capacitor must be large enough to supply fast transient load in order to prevent the output from dropping. The USB specification limits the capacitance on VBUS (VOUT) to a maximum of 10 μ F. In addition, there is an upper limit for output capacitor for AOZ1353DI to ensure the output capacitor can be charged fully during start-up. This upper limit is set by the current limit level and soft-start time.

$$C_{OUT} = I_{LIM} \times (t_{ON} / V_{IN})$$

Power Dissipation Calculation

Calculate the power dissipation for normal load condition using the following equation:

$$\text{Power Dissipated} = R_{ON} \times (I_{OUT})^2$$

The worst case power dissipation occurs when the load current hits the current limit due to over-current. The power dissipation can be calculated using the following equation:

$$\text{Power Dissipated} = (V_{IN} - V_{OUT}) \times I_{LIM}$$

Layout Guidelines

Good PCB layout is important for improving the thermal and overall performance of AOZ1353DI. To optimize the switch response time to output short-circuit conditions, keep all traces as short as possible to reduce the effect of unwanted parasitic inductance. Place the input and output bypass capacitors as close as possible to the VIN and VOUT pins. The input and output PCB traces should be as wide as possible for the given PCB space. Use a ground plane to enhance the power dissipation capability of the device.

Package Dimensions, DFN3x3B-12L

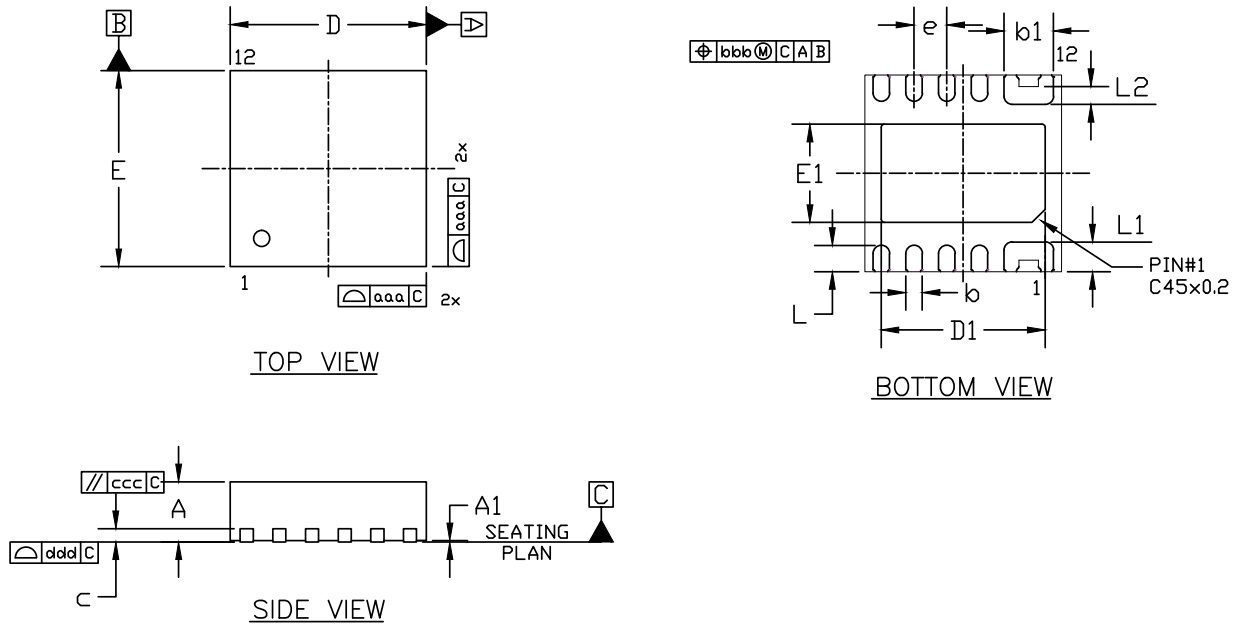

RECOMMENDED LAND PATTERN

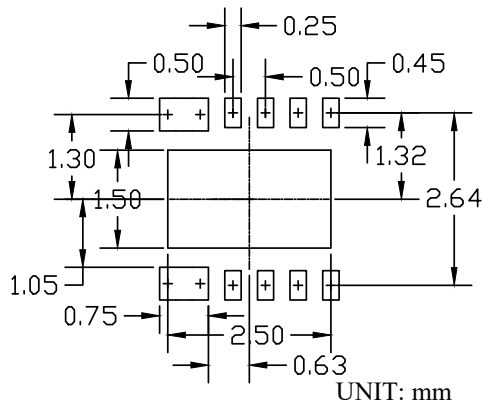

SYMBOLS	DIMENSIONS IN MILLIMETERS			DIMENSIONS IN INCHES		
	MIN	NOM	MAX	MIN	NOM	MAX
A	0.80	0.90	1.00	0.031	0.035	0.039
A1	0.00	0.02	0.05	0.000	0.001	0.002
b	0.20	0.25	0.30	0.008	0.010	0.012
b1	0.70	0.75	0.80	0.028	0.030	0.032
c	0.195	0.203	0.211	0.008	0.008	0.008
D	2.90	3.00	3.10	0.116	0.118	0.120
D1	2.40	2.50	2.60	0.094	0.098	0.102
E	2.90	3.00	3.10	0.116	0.118	0.120
E1	1.40	1.50	1.60	0.055	0.059	0.063
e	0.50BSC			0.020BSC		
L	0.30	0.40	0.50	0.012	0.016	0.020
L1	0.35	0.45	0.55	0.014	0.018	0.022
L2	0.22	0.27	0.32	0.009	0.011	0.013
aaa	0.15			0.006		
bbb	0.10			0.004		
ccc	0.10			0.004		
ddd	0.08			0.003		

NOTE

1. DIMENSIONING AND TOLERANCING CONFORM TO ASME Y14.5M-1994.
2. CONTROLLING DIMENSION IS MILLIMETER.
CONVERTED INCH DIMENSIONS ARE NOT NECESSARILY EXACT.
3. DIMENSION b APPLIES TO METALLIZED TERMINAL AND IS MEASURED BETWEEN 0.15mm AND 0.30mm FROM THE TERMINAL TIP. IF THE TERMINAL HAS THE OPTIONAL RADIUS ON THE OTHER END OF THE TERMINAL, THE DIMENSION b SHOULD NOT BE MEASURED IN THAT RADIUS AREA.
4. COPLANARITY ddd APPLIES TO THE TERMINALS AND ALL OTHER BOTTOM SURFACE METALLIZATION.

Package Dimensions, DFN3x3B-12L

Carrier Tape

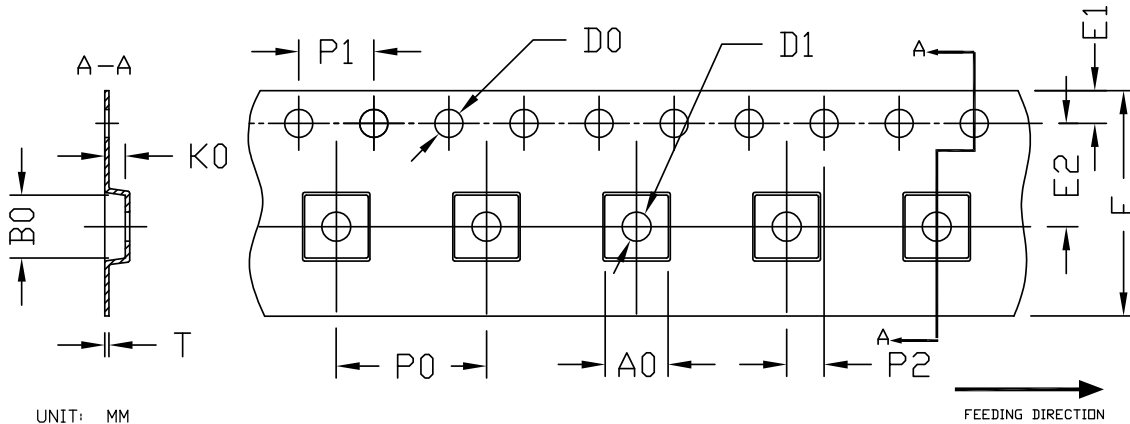

UNIT: MM

FEEDING DIRECTION

PACKAGE	A0	B0	K0	D0	D1	E	E1	E2	P0	P1	P2	T
DFN3x3_EP	3.40 ±0.10	3.35 ±0.10	1.10 ±0.10	1.50 +0.10 -0	1.50 +0.10 -0	12.00 ±0.30	1.75 ±0.10	5.50 ±0.05	8.00 ±0.10	4.00 ±0.10	2.00 ±0.05	0.30 ±0.05

Reel

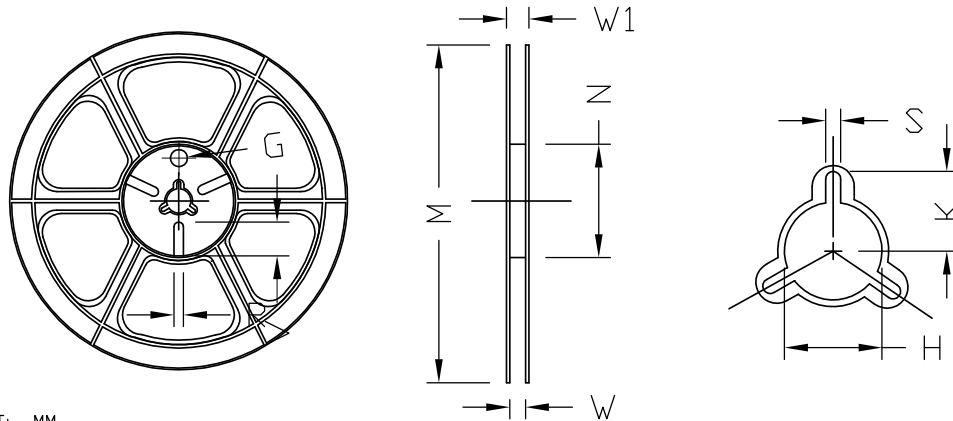

UNIT: MM

TAPE SIZE	REEL SIZE	M	N	W	W1	H	K	S	G	R	V
12 mm	ø330	ø330.00 ±0.50	ø97.00 ±0.10	13.00 ±0.30	17.40 ±1.00	ø13.00 +0.50 -0.20	10.60	2.00 ±0.50	---	---	---

DFN3x3 EP TAPE

Leader / Trailer & Orientation

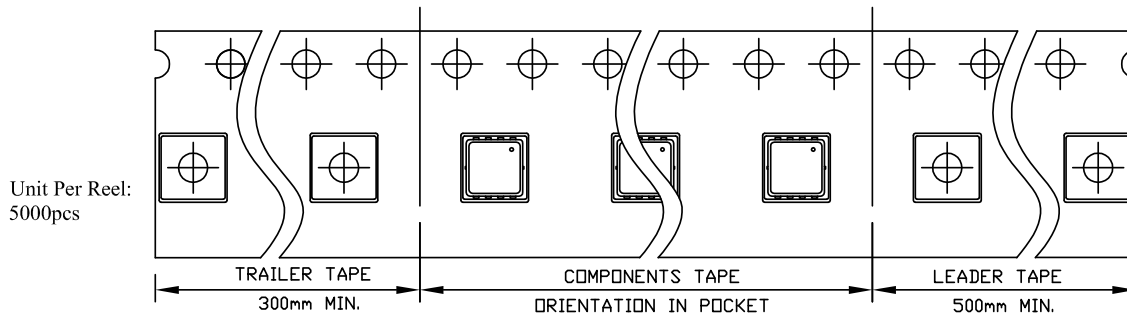

Unit Per Reel:
5000pcs

Part Marking

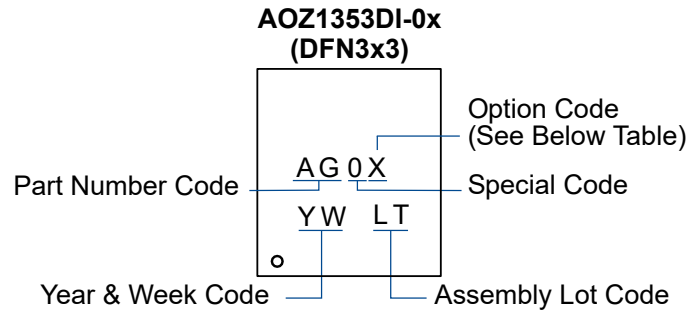

Part Number	Fault Recovery	SCP Response	Marking Code
AOZ1353DI-01	Auto-Restart	Current Limit	AG01
AOZ1353DI-02	Latch-Off	Current Limit	AG02
AOZ1353DI-03	Auto-Restart	Fast Shutdown	AG03
AOZ1353DI-04	Latch-Off	Fast Shutdown	AG04

LEGAL DISCLAIMER

Applications or uses as critical components in life support devices or systems are not authorized. Alpha and Omega Semiconductor does not assume any liability arising out of such applications or uses of its products. AOS reserves the right to make changes to product specifications without notice. It is the responsibility of the customer to evaluate suitability of the product for their intended application. Customer shall comply with applicable legal requirements, including all applicable export control rules, regulations and limitations.

AOS' products are provided subject to AOS' terms and conditions of sale which are set forth at:
http://www.aosmd.com/terms_and_conditions_of_sale

LIFE SUPPORT POLICY

ALPHA AND OMEGA SEMICONDUCTOR PRODUCTS ARE NOT AUTHORIZED FOR USE AS CRITICAL COMPONENTS IN LIFE SUPPORT DEVICES OR SYSTEMS.

As used herein:

1. Life support devices or systems are devices or systems which, (a) are intended for surgical implant into the body or (b) support or sustain life, and (c) whose failure to perform when properly used in accordance with instructions for use provided in the labeling, can be reasonably expected to result in a significant injury of the user.
2. A critical component in any component of a life support device, or system whose failure to perform can be reasonably expected to cause the failure of the life support device or system, or to affect its safety or effectiveness.