



ST485AB

Very high speed low power RS-485/RS-422 transceiver

Features

- Low supply current: 5 mA max
- High data rate > 30 Mbps
- Designed for RS 485 interface applications
- -7 to 12 common mode input voltage range
- Driver maintains high impedance in 3-state or with the power off
- 70mV typical input hysteresis
- Operate from single 5 supply
- ± 4 kV ESD protection
- Current limiting and thermal shutdown for driver overload protection
- Latch-up free up to 500 mA

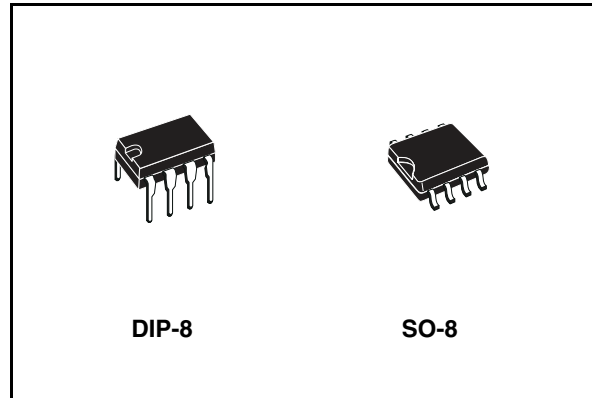

The ST485A is designed for bi-directional data communications or multipoint bus transmission lines.

Description

The ST485A is a low power, high speed transceiver for RS-485 and RS-422 communications. The device contains one driver and one receiver in half duplex configuration. The ST485A draws 3 mA (typ.) of supply current when unloaded or fully loaded with disabled drivers. It operates from a single 5 V supply.

Driver is short-circuit current limited and is protected against excessive power dissipation by thermal shutdown circuitry that place the driver outputs into a high-impedance state. The receiver input has a fail-safe feature that guarantees a logic high output if both inputs are open circuit.

Table 1. Device summary

Order code	Temperature range	Package	Packaging
ST485ABN	-40 to 85 °C	DIP-8	50parts per tube / 40tube per box
ST485ABDR	-40 to 85 °C	SO-8 (Tape & reel)	2500 parts per reel

Contents

1	Pin configuration	3
2	Truth tables	4
3	Maximum ratings	5
4	Electrical characteristics	6
5	Test circuit and typical characteristics	9
6	Package mechanical data	14
7	Revision history	18

1 Pin configuration

Figure 1. Pin configuration

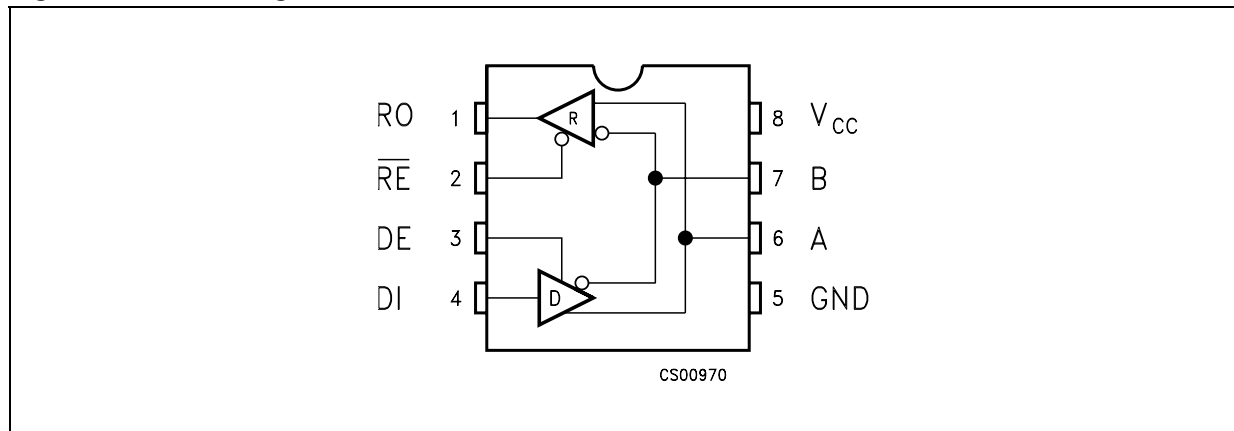

Table 2. Pin description

Pin n°	Symbol	Name and function
1	RO	Receiver output. If $A > B$ by 200 mV, RO will be high; if $A < B$ by 200 mV, RO will be low
2	\overline{RE}	Receiver output enable. RO is enabled when RE is low; RO is high impedance when RE is high. If RE is high and DE is low, the device will enter a low power shutdown mode.
3	DE	Driver output enable. The driver outputs are enabled by bringing DE high. They are high impedance when DE is low. If RE is high DE is low, the device will enter a low-power shutdown mode. If the driver outputs are enabled, the part functions as line driver, while they are high impedance, it functions as line receivers if RE is low.
4	DI	Driver input. A low on DI forces output A low and output B high. Similarly, a high on DI forces output A high and output B low
5	GND	Ground
6	A	Non-inverting receiver input and non-inverting driver output
7	B	Inverting receiver input and inverting driver output
8	V_{CC}	Supply voltage: $V_{CC} = 4.75 \text{ V to } 5.25 \text{ V}$

2 Truth tables

Table 3. Truth table (driver)

Inputs			Outputs		Mode
\overline{RE}	DE	DI	B	A	A
X	H	H	L	H	Normal
X	H	L	H	L	Normal
L	L	X	Z	Z	Normal

Note: X = Don't care; Z = High impedance

Table 4. Truth table (receiver)

Inputs			Outputs	Mode
\overline{RE}	DE	A-B	RO	
L	L	$\geq -0.2\text{ V}$	H	Normal
L	L	$\leq -0.2\text{ V}$	L	Normal
L	L	Inputs open	H	Normal

Note: X = Don't care; Z = High impedance

3 Maximum ratings

Table 5. Absolute maximum ratings

Symbol	Parameter	Value	Unit
V_{CC}	Supply voltage	7	V
V_I	Control input voltage (\overline{RE} , DE)	-0.3 to 7	V
V_{DI}	Driver input voltage (DI)	-0.3 to 7	V
V_{DO}	Driver output voltage (A, B)	-7.5 to 12.5	V
V_{RI}	Receiver input voltage (A, B)	-7.5 to 12.5	V
V_{RO}	Receiver output voltage (RO)	-0.3 to ($V_{CC} + 0.3$)	V

Note: Absolute maximum ratings are those values beyond which damage to the device may occur. Functional operation under these condition is not implied.

4 Electrical characteristics

Table 6. DC electrical characteristics ($V_{CC} = 4.5\text{ V to }5.5\text{ V}$, $T_A = -40\text{ to }85^\circ\text{C}$, unless otherwise specified. Typical values are referred to $T_A = 25^\circ\text{C}$, $V_{CC} = 5\text{ V}$) (*Note: 1*)

Symbol	Parameter	Test conditions	Min.	Typ.	Max.	Unit	
I_{SUPPLY}	V_{CC} Power supply current	No load, $V_{RE}=0\text{ V}$ or V_{CC}	$V_{DE} = V_{CC}$		2.3	5	mA
			$V_{DE} = 0\text{ V}$		2.6	5	mA
$C_{I/O}$	Input/output capacitance			10		pF	
C_{AB}	Driver output capacity			10		pF	

Table 7. Logic input electrical characteristics ($V_{CC} = 4.5\text{ V to }5.5\text{ V}$, $T_A = -40\text{ to }85^\circ\text{C}$, unless otherwise specified. Typical values are referred to $T_A = 25^\circ\text{C}$, $V_{CC} = 5\text{ V}$) (*Note: 1*)

Symbol	Parameter	Test conditions	Min.	Typ.	Max.	Unit
V_{IL}	Input logic threshold low	DE, DI, RE			0.8	V
V_{IH}	Input logic threshold high	DE, DI, RE	2			V
I_{IN1}	Logic input current	DE, DI, RE			± 2.0	μA
I_{IN2}	Input current (A, B)	$V_{DE}=0\text{ V}$, $V_{CC}= 0\text{ or }5.25\text{ V}$	$V_{IN}=12\text{ V}$		1	mA
			$V_{IN}=-7\text{ V}$		-0.8	mA

Table 8. Transmitter electrical characteristics ($V_{CC} = 4.5\text{ V to }5.5\text{ V}$, $T_A = -40\text{ to }85^\circ\text{C}$, unless otherwise specified. Typical values are referred to $T_A = 25^\circ\text{C}$, $V_{CC} = 5\text{ V}$) (*Note: 1*)

Symbol	Parameter	Test conditions	Min.	Typ.	Max.	Unit
V_{OD1}	Differential driver output (No load)				5	V
V_{OD2}	Differential driver output (with load)	$R_L = 54\ \Omega$ (RS-422) $V_{CM} = -7\text{ V to }12\text{ V}$	1.5	2.7	5	V
ΔV_{OD}	Change in magnitude of driver differential output voltage for complementary output states (<i>Note: 1</i>)	$R_L = 27\ \Omega$ or $50\ \Omega$		0	0.2	V
V_{OC}	Driver common mode output voltage	$R_L = 27\ \Omega$ or $50\ \Omega$	1		3	V
ΔV_{OC}	Change in magnitude of driver common mode output voltage (<i>Note: 1</i>)	$R_L = 54\ \Omega$ or $100\ \Omega$		0	0.2	V
I_{OSD}	Driver short circuit output current	$V_O = -7\text{ V to }12\text{ V}$			± 250	mA

Table 9. Receiver electrical characteristics ($V_{CC} = 4.5 \text{ V}$ to 5.5 V , $T_A = -40$ to 85°C , unless otherwise specified. Typical values are referred to $T_A = 25^\circ\text{C}$, $V_{CC} = 5 \text{ V}$) (*Note: 1*)

Symbol	Parameter	Test conditions	Min.	Typ.	Max.	Unit
V_{TH}	Receiver Differential Threshold Voltage	$V_{CM} = -7 \text{ V}$ to 12 V	-0.2		0.2	V
ΔV_{TH}	Receiver Input Hysteresis	$V_{CM} = 0 \text{ V}$		70		mV
V_{OH}	Receiver Output High Voltage	$I_{OUT} = -4 \text{ mA}$, $V_{ID} = 200 \text{ mV}$	3.5	4.7		V
V_{OL}	Receiver Output Low Voltage	$I_{OUT} = 4 \text{ mA}$, $V_{ID} = -200 \text{ mV}$		0.2	0.4	V
I_{OZR}	3-State (High Impedance) Output Current at Receiver	$V_O = 0.4 \text{ V}$ to 2.4 V			± 1	μA
R_{RIN}	Receiver Input Resistance	$V_{CM} = -7 \text{ V}$ to 12 V	12	24		$\text{K}\Omega$
I_{OSR}	Receiver Short-Circuit Current	$V_O = 0 \text{ V}$ to V_{CC}	7		95	mA

Table 10. Driver switching characteristics ($V_{CC} = 4.5 \text{ V}$ to 5.5 V , $T_A = -40$ to 85°C , unless otherwise specified. Typical values are referred to $T_A = 25^\circ\text{C}$, $V_{CC} = 5 \text{ V}$) (See *Note: 1*, *Note 3*)

Symbol	Parameter	Test conditions	Min.	Typ.	Max.	Unit
D_R	Maximum data rate	Jitter < 5%	30	50		Mbps
t_{PLH} t_{PHL}	Propagation delay input to output	$R_L = 54 \Omega$, $C_{L1} = C_{L2} = 50 \text{ pF}$, (<i>Figure 8.</i>)		18	30	ns
t_{SKEW}	Differential output delay skew	$R_L = 54 \Omega$, $C_{L1} = C_{L2} = 50 \text{ pF}$, (<i>Figure 6.</i>)		0.5	2	ns
t_{TLH} t_{THL}	Rise or fall differential time	$R_L = 54 \Omega$, $C_{L1} = C_{L2} = 50 \text{ pF}$, (<i>Figure 6.</i>)		8	12	ns
t_{PZL}	Output enable time	$C_L = 50 \text{ pF}$, S1 Closed			30	ns
t_{PZH}	Output enable time	$C_L = 50 \text{ pF}$, S2 Closed			30	ns
t_{PHZ}	Output disable time	$C_L = 15 \text{ pF}$, S2 Closed			30	ns
t_{PLZ}	Output disable time	$C_L = 15 \text{ pF}$, S1 Closed			30	ns
$t_{SK(EN)}$	Synchronous driver operation a-b at enable				2	ns
$t_{SK(DS)}$	Synchronous driver operation A-B at disable			4	6	ns

Table 11. Driver switching characteristics ($V_{CC} = 4.5V$ to $5.5V$, $T_A = -40$ to $85^\circ C$, unless otherwise specified. Typical values are referred to $T_A = 25^\circ C$, $V_{CC} = 5V$) (See [Note: 1](#), [Note 3](#))

Symbol	Parameter	Test conditions	Min.	Typ.	Max.	Unit
t_{PLH} t_{PHL}	Propagation Delay	$C_L = 15$ pF		18	30	ns
t_{RPDS}	$ t_{PLH} - t_{PHL} $ Propagation delay skew	$C_L = 15$ pF		0.5	2	ns
t_{PZL}	Output enable time	$C_{RL} = 15$ pF, S1 Closed		7	12	ns
t_{PZH}	Output enable time	$C_{RL} = 15$ pF, S2 Closed		7	12	ns
t_{PHZ}	Output disable time	$C_{RL} = 15$ pF, S2 Closed		7	12	ns
t_{PLZ}	Output disable time	$C_{RL} = 15$ pF, S1 Closed		7	12	ns

- Note:*
- 1 All currents into device pins are positive; all currents out of device pins are negative; all voltages are referenced to device ground unless specified.
 - 2 Applies to peak current. See typical Operating Characteristics.
 - 3 $t_r = t_f \leq 6$ ms.

5 Test circuit and typical characteristics

Figure 2. Driver DC test load

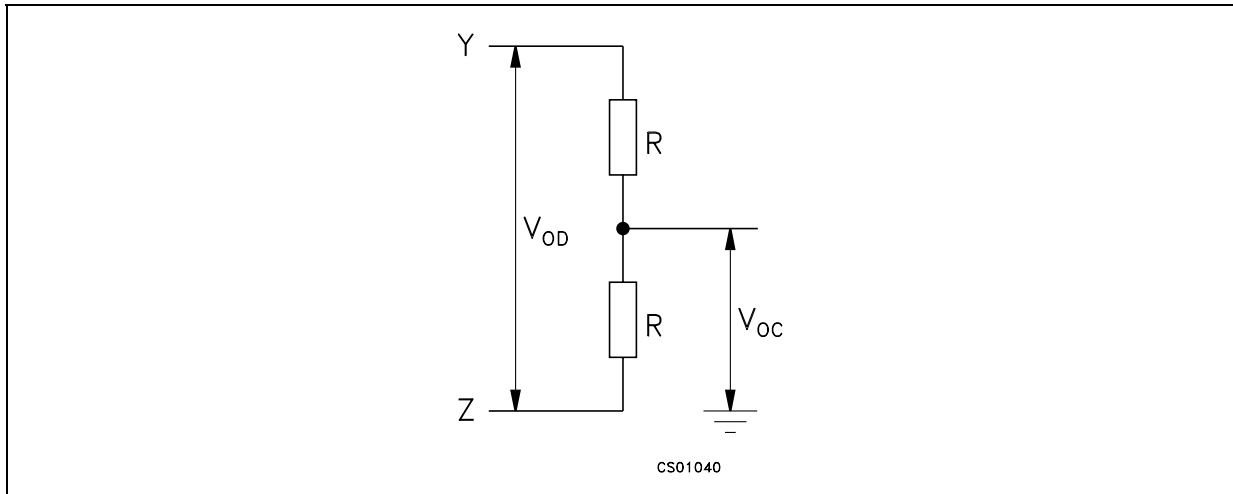

Figure 3. Receiver timing test load

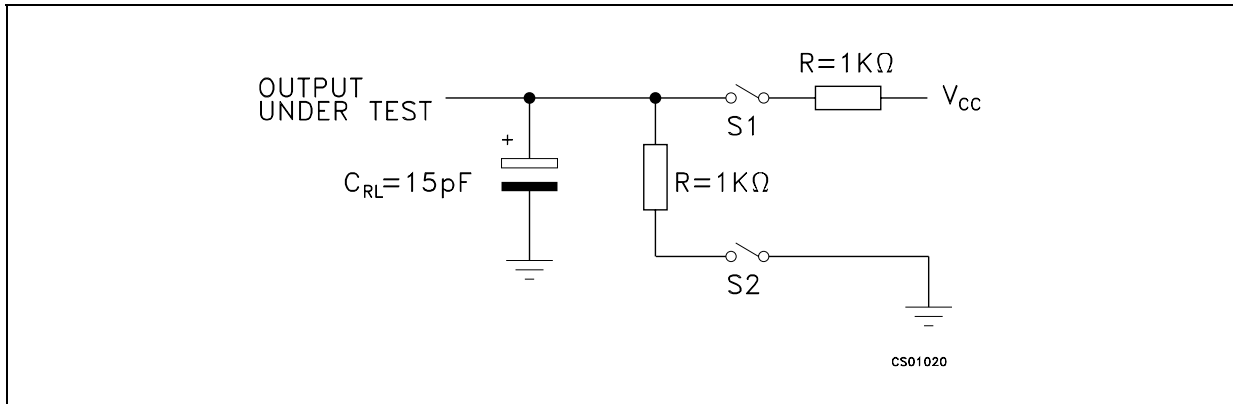

Figure 4. Driver/receiver timing test circuit

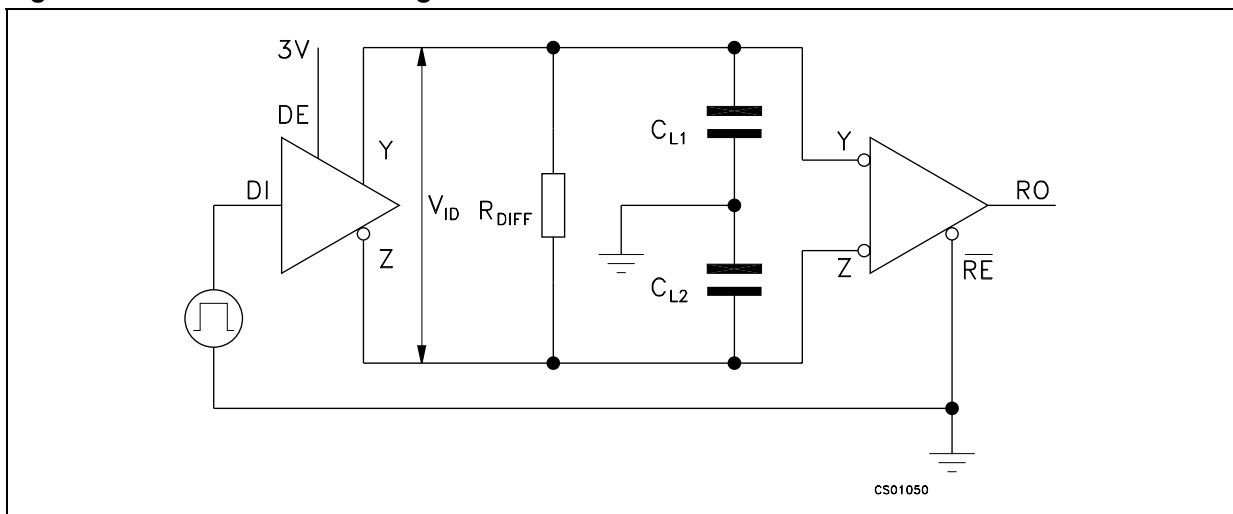

Figure 5. Driver timing test load

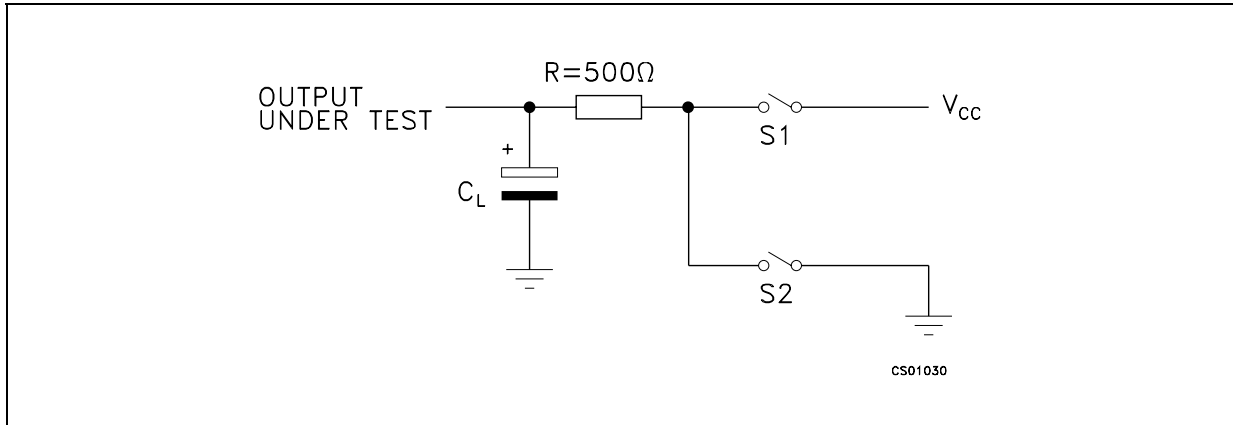

Figure 6. Driver timing test load

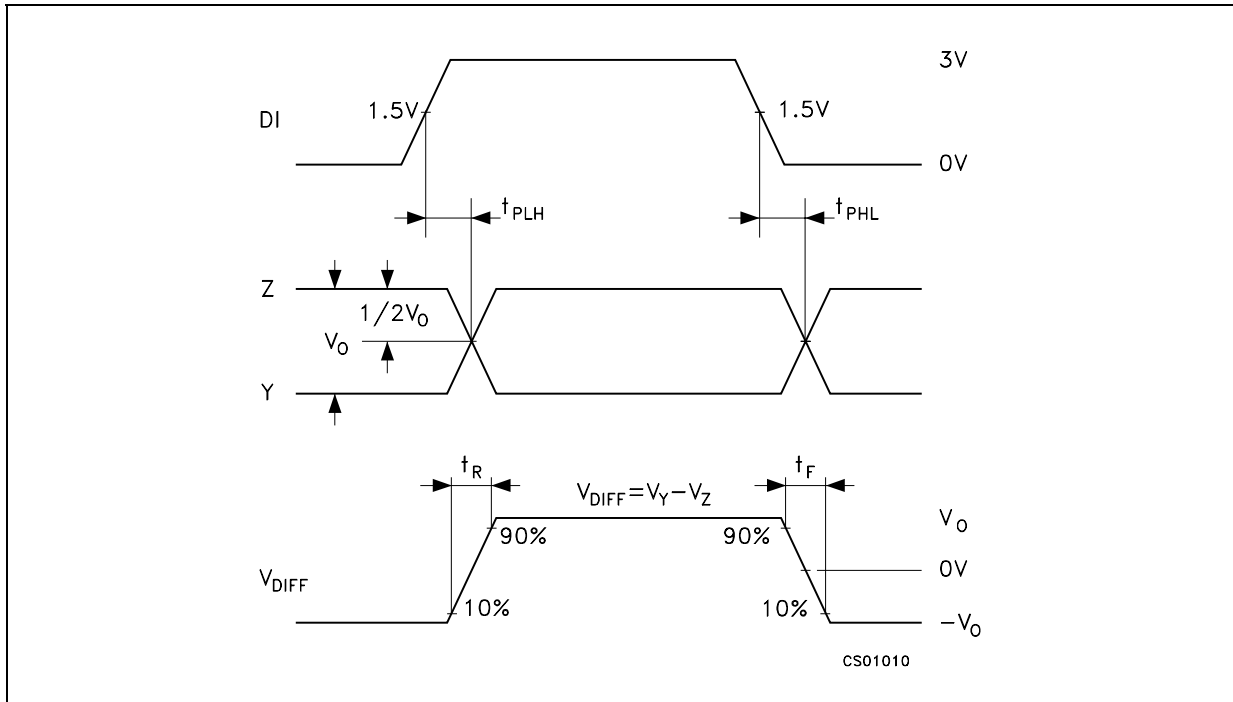

Figure 7. Driver enable and disable time

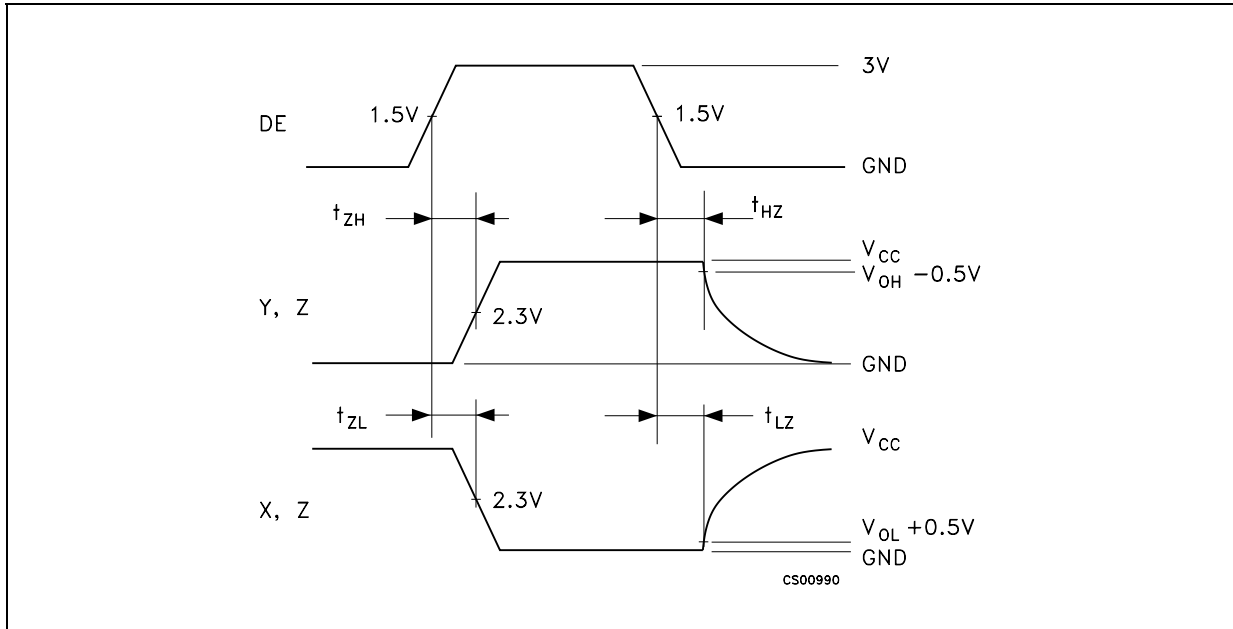

Figure 8. Receiver propagation delay

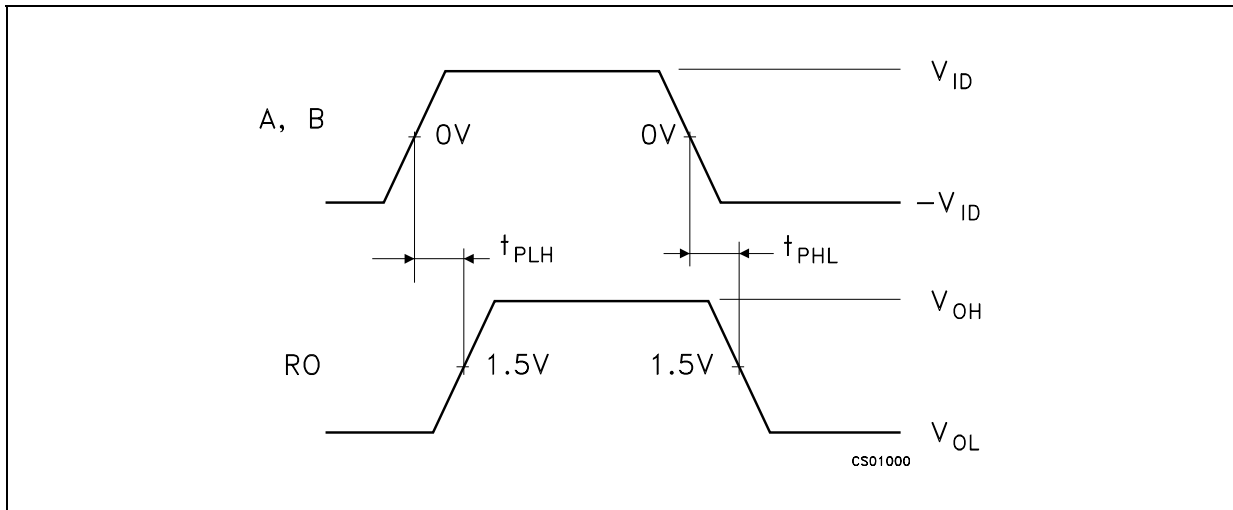

Figure 9. Receiver enable and disable time

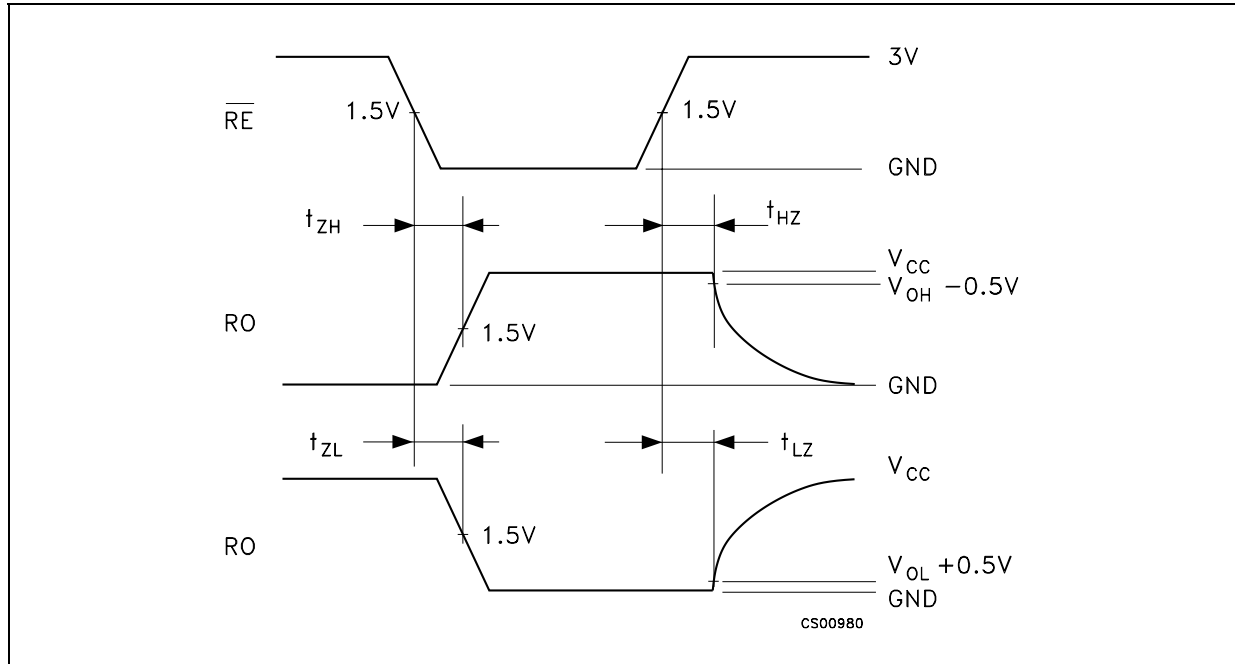

Figure 10. Receiver output current vs. output voltage (output low)

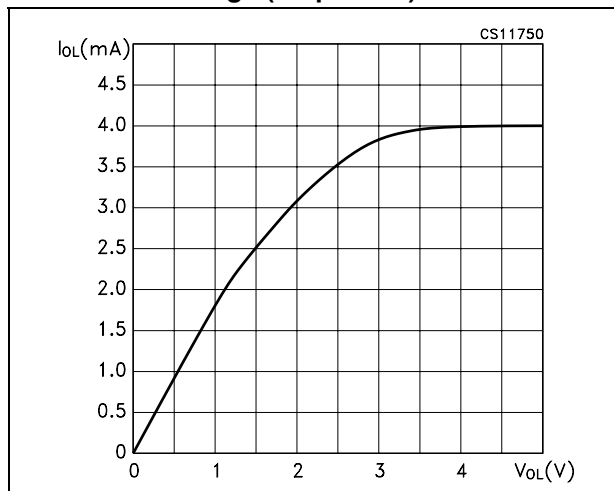

Figure 11. Receiver output current vs. output voltage (output high)

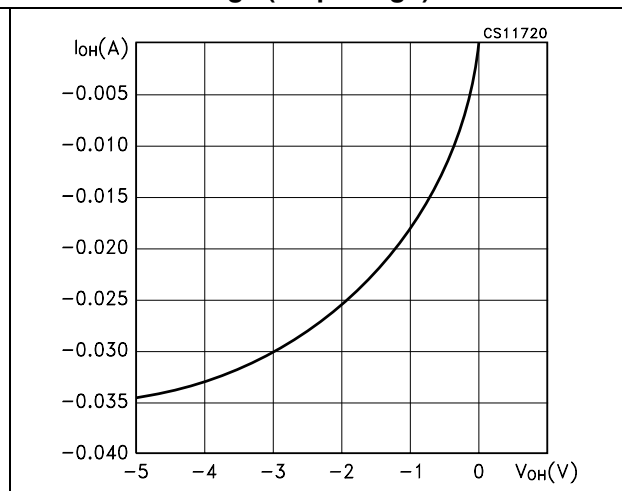

Figure 12. Driver diff. output voltage vs common mode voltage (diff. output low)

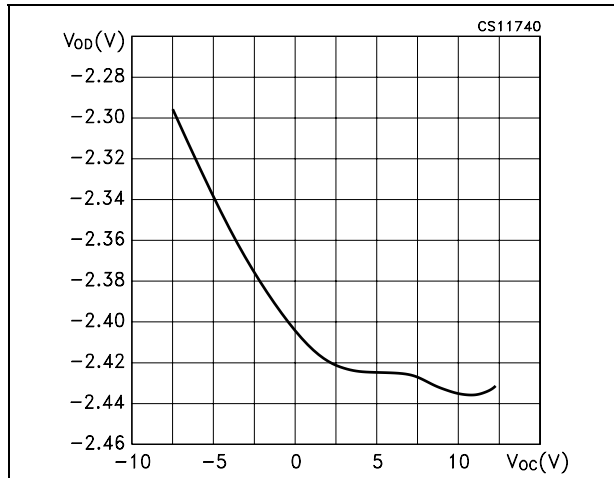

Figure 13. Driver diff. output voltage vs common mode voltage (diff. output low)

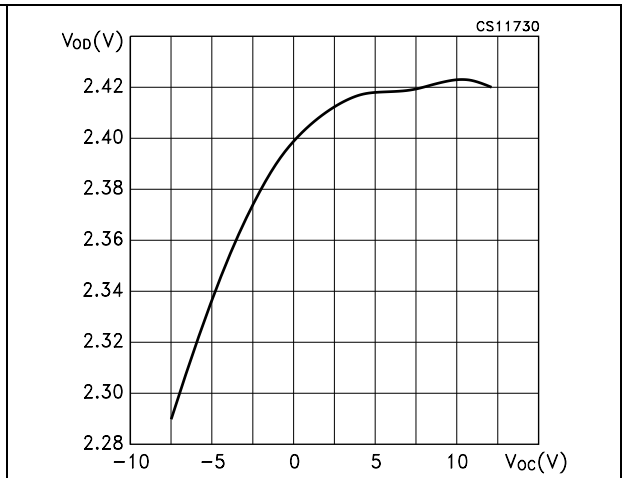

Figure 14. Driver short circuit current vs line voltage (output high)

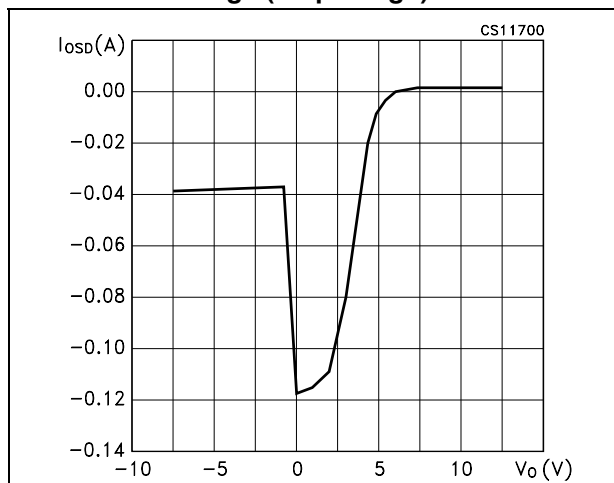

Figure 15. Driver short circuit current vs. line voltage (output low)

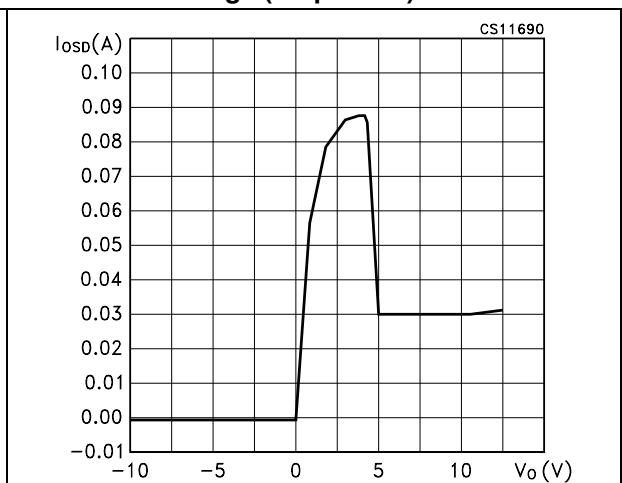
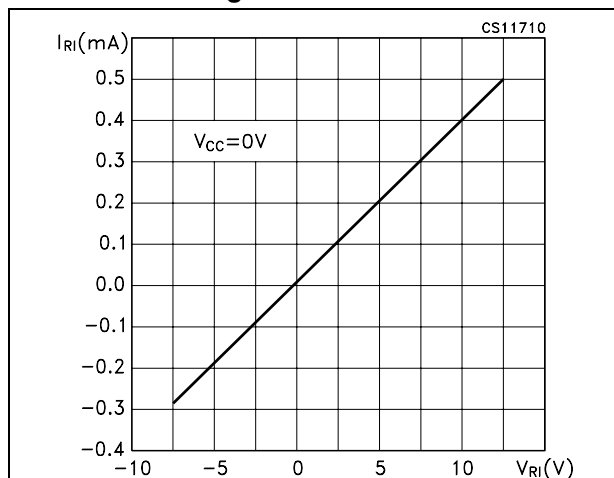

Figure 16. Receiver input current vs input voltage



6 Package mechanical data

In order to meet environmental requirements, ST offers these devices in ECOPACK® packages. These packages have a Lead-free second level interconnect. The category of second level interconnect is marked on the package and on the inner box label, in compliance with JEDEC Standard JESD97. The maximum ratings related to soldering conditions are also marked on the inner box label. ECOPACK is an ST trademark. ECOPACK specifications are available at: www.st.com

Plastic DIP-8 mechanical data

Dim.	mm.			inch.		
	Min.	Typ.	Max.	Min.	Typ.	Max.
A		3.3			0.130	
a1	0.7			0.028		
B	1.39		1.65	0.055		0.065
B1	0.91		1.04	0.036		0.041
b		0.5			0.020	
b1	0.38		0.5	0.015		0.020
D			9.8			0.386
E		8.8			0.346	
e		2.54			0.100	
e3		7.62			0.300	
e4		7.62			0.300	
F			7.1			0.280
l			4.8			0.189
L		3.3			0.130	
Z	0.44		1.6	0.017		0.063

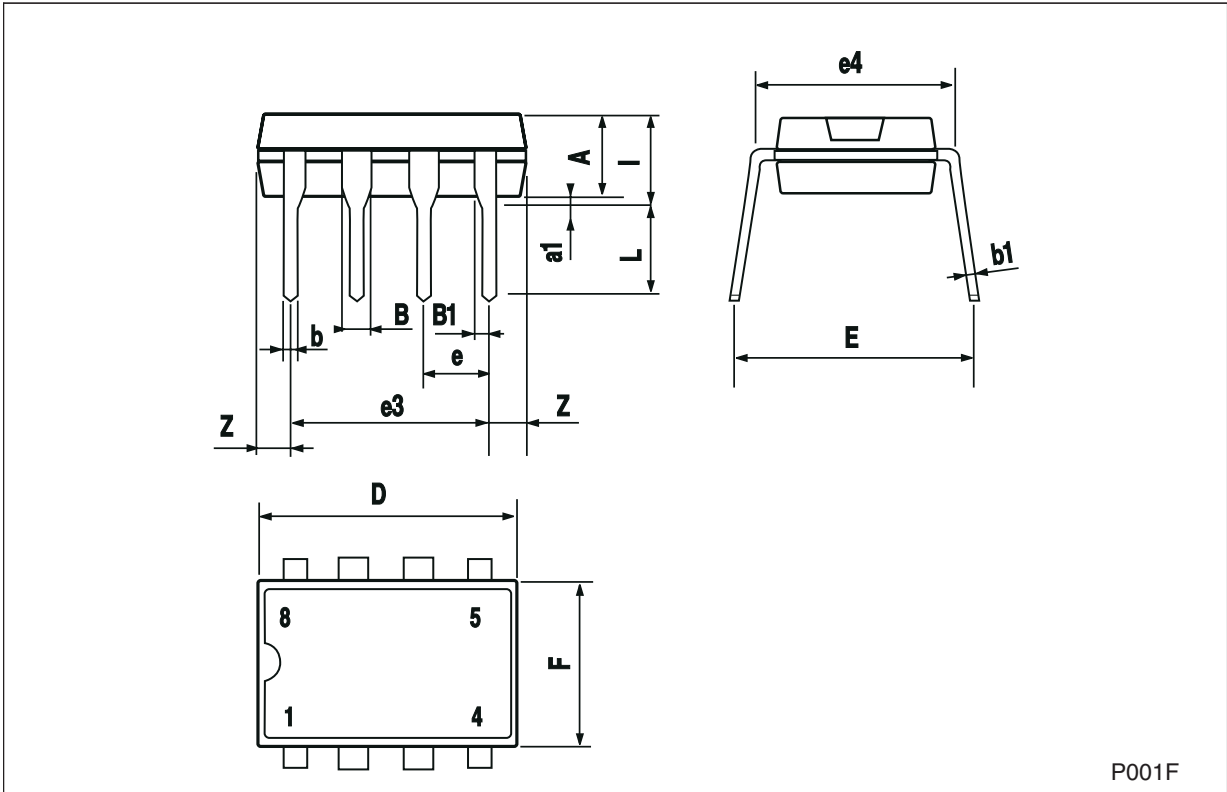

P001F

SO-8 mechanical data

Dim.	mm.			inch.		
	Min.	Typ.	Max.	Min.	Typ.	Max.
A	1.35		1.75	0.053		0.069
A1	0.10		0.25	0.04		0.010
A2	1.10		1.65	0.043		0.065
B	0.33		0.51	0.013		0.020
C	0.19		0.25	0.007		0.010
D	4.80		5.00	0.189		0.197
E	3.80		4.00	0.150		0.157
e		1.27			0.050	
H	5.80		6.20	0.228		0.244
h	0.25		0.50	0.010		0.020
L	0.40		1.27	0.016		0.050
k	8° (max.)					
ddd			0.1			0.04

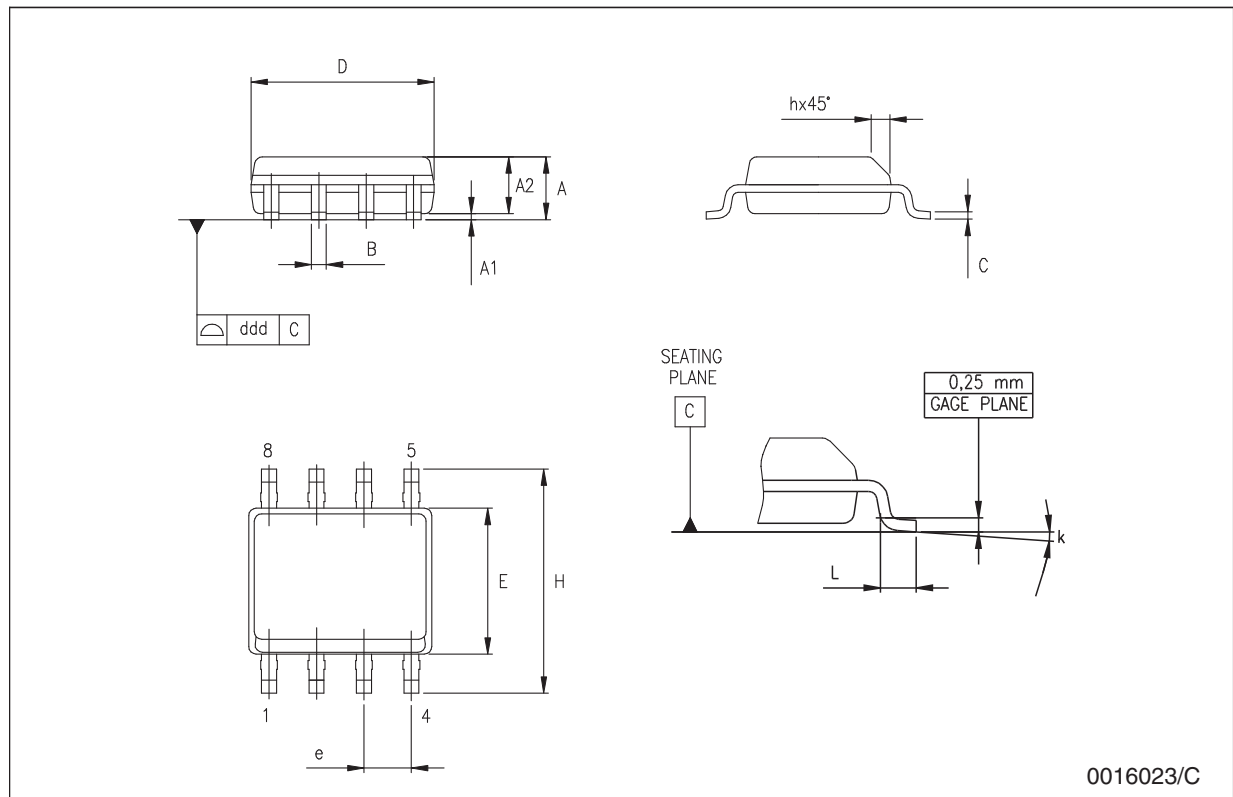

Tape & reel SO-8 mechanical data

Dim.	mm.			inch.		
	Min.	Typ.	Max.	Min.	Typ.	Max.
A			330			12.992
C	12.8		13.2	0.504		0.519
D	20.2			0.795		
N	60			2.362		
T			22.4			0.882
Ao	8.1		8.5	0.319		0.335
Bo	5.5		5.9	0.216		0.232
Ko	2.1		2.3	0.082		0.090
Po	3.9		4.1	0.153		0.161
P	7.9		8.1	0.311		0.319

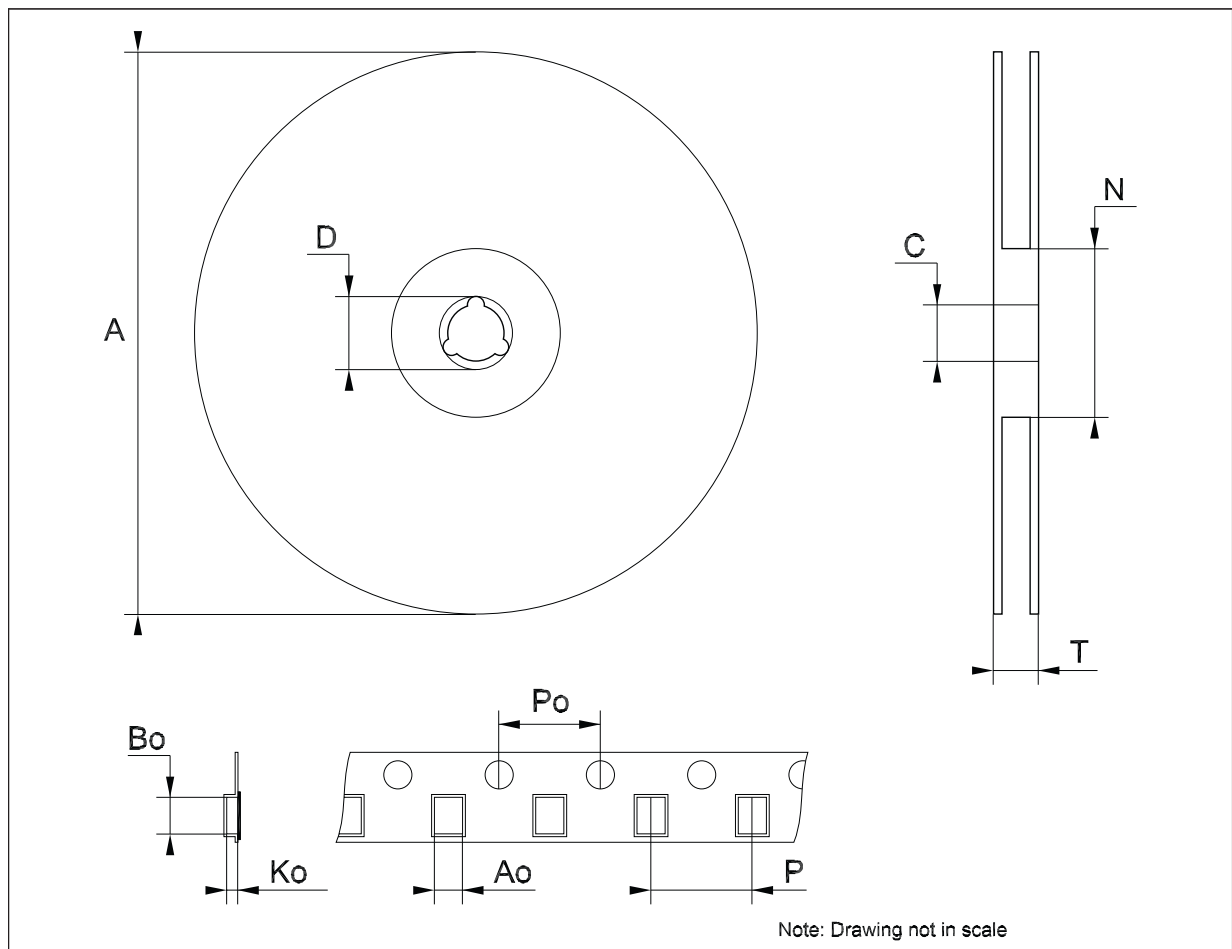

7 Revision history

Table 12. Revision history

Date	Revision	Changes
28-Mar-2006	2	Order codes updated and new template.
24-Aug-2007	3	Added Table 1 . in cover page.

Please Read Carefully:

Information in this document is provided solely in connection with ST products. STMicroelectronics NV and its subsidiaries ("ST") reserve the right to make changes, corrections, modifications or improvements, to this document, and the products and services described herein at any time, without notice.

All ST products are sold pursuant to ST's terms and conditions of sale.

Purchasers are solely responsible for the choice, selection and use of the ST products and services described herein, and ST assumes no liability whatsoever relating to the choice, selection or use of the ST products and services described herein.

No license, express or implied, by estoppel or otherwise, to any intellectual property rights is granted under this document. If any part of this document refers to any third party products or services it shall not be deemed a license grant by ST for the use of such third party products or services, or any intellectual property contained therein or considered as a warranty covering the use in any manner whatsoever of such third party products or services or any intellectual property contained therein.

UNLESS OTHERWISE SET FORTH IN ST'S TERMS AND CONDITIONS OF SALE ST DISCLAIMS ANY EXPRESS OR IMPLIED WARRANTY WITH RESPECT TO THE USE AND/OR SALE OF ST PRODUCTS INCLUDING WITHOUT LIMITATION IMPLIED WARRANTIES OF MERCHANTABILITY, FITNESS FOR A PARTICULAR PURPOSE (AND THEIR EQUIVALENTS UNDER THE LAWS OF ANY JURISDICTION), OR INFRINGEMENT OF ANY PATENT, COPYRIGHT OR OTHER INTELLECTUAL PROPERTY RIGHT.

UNLESS EXPRESSLY APPROVED IN WRITING BY AN AUTHORIZED ST REPRESENTATIVE, ST PRODUCTS ARE NOT RECOMMENDED, AUTHORIZED OR WARRANTED FOR USE IN MILITARY, AIR CRAFT, SPACE, LIFE SAVING, OR LIFE SUSTAINING APPLICATIONS, NOR IN PRODUCTS OR SYSTEMS WHERE FAILURE OR MALFUNCTION MAY RESULT IN PERSONAL INJURY, DEATH, OR SEVERE PROPERTY OR ENVIRONMENTAL DAMAGE. ST PRODUCTS WHICH ARE NOT SPECIFIED AS "AUTOMOTIVE GRADE" MAY ONLY BE USED IN AUTOMOTIVE APPLICATIONS AT USER'S OWN RISK.

Resale of ST products with provisions different from the statements and/or technical features set forth in this document shall immediately void any warranty granted by ST for the ST product or service described herein and shall not create or extend in any manner whatsoever, any liability of ST.

ST and the ST logo are trademarks or registered trademarks of ST in various countries.

Information in this document supersedes and replaces all information previously supplied.

The ST logo is a registered trademark of STMicroelectronics. All other names are the property of their respective owners.

© 2007 STMicroelectronics - All rights reserved

STMicroelectronics group of companies

Australia - Belgium - Brazil - Canada - China - Czech Republic - Finland - France - Germany - Hong Kong - India - Israel - Italy - Japan - Malaysia - Malta - Morocco - Singapore - Spain - Sweden - Switzerland - United Kingdom - United States of America

www.st.com