

THIS DRAWING IS UNPUBLISHED. RELEASED FOR PUBLICATION 20
 © COPYRIGHT 20 BY - ALL RIGHTS RESERVED.

LOC		DIST		REVISIONS			
P	LTR	DESCRIPTION	DATE	DWN	APVD		
AF	-	A1	REVISED PER ECR-14-004708	28MAR14	JR	KR	

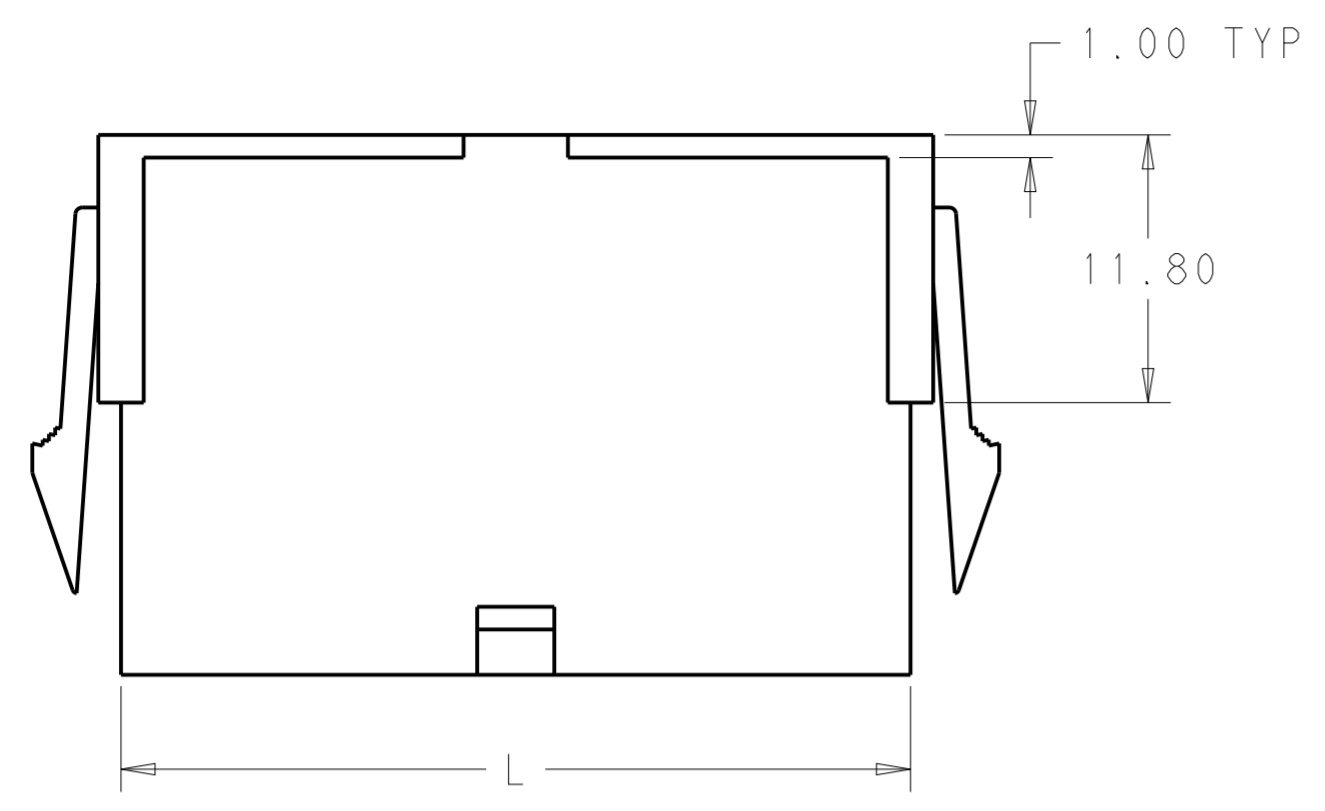

- 1 POLYAMIDE, UL94V-2, COLOR- WHITE
- 2 FLAMMABILITY V2 FOR THICKNESS 0.38mm, 1.5mm NAD 3.0mm PER IEC 60695-11-10.
- 3 GLOW-WIRE FLAMMABILITY (GWFI) 800°C FOR THICKNESS 0.38mm AND 0.75mm PER IEC 60695-2-12.
- 4 GLOW-WIRE FLAMMABILITY (GWFI) 960°C FOR THICKNESS 1.5mm AND 3.0mm PER IEC 60695-2-12.
- 5 GLOW-WIRE IGNITION (GWIT) 825°C FOR THICKNESS 0.38mm, 0.75mm, 1.5mm AND 3.0mm PER IEC 60695-2-13.
- 6 COMPLY WITH GLOW WIRE REQUIREMENTS FOR PARTS OF NON-METALLIC MATERIAL SUPPORTING A CURRENT-CARRYING CONNECTION DETAILED IN IEC 60335-1, SECTION 30(GWT).

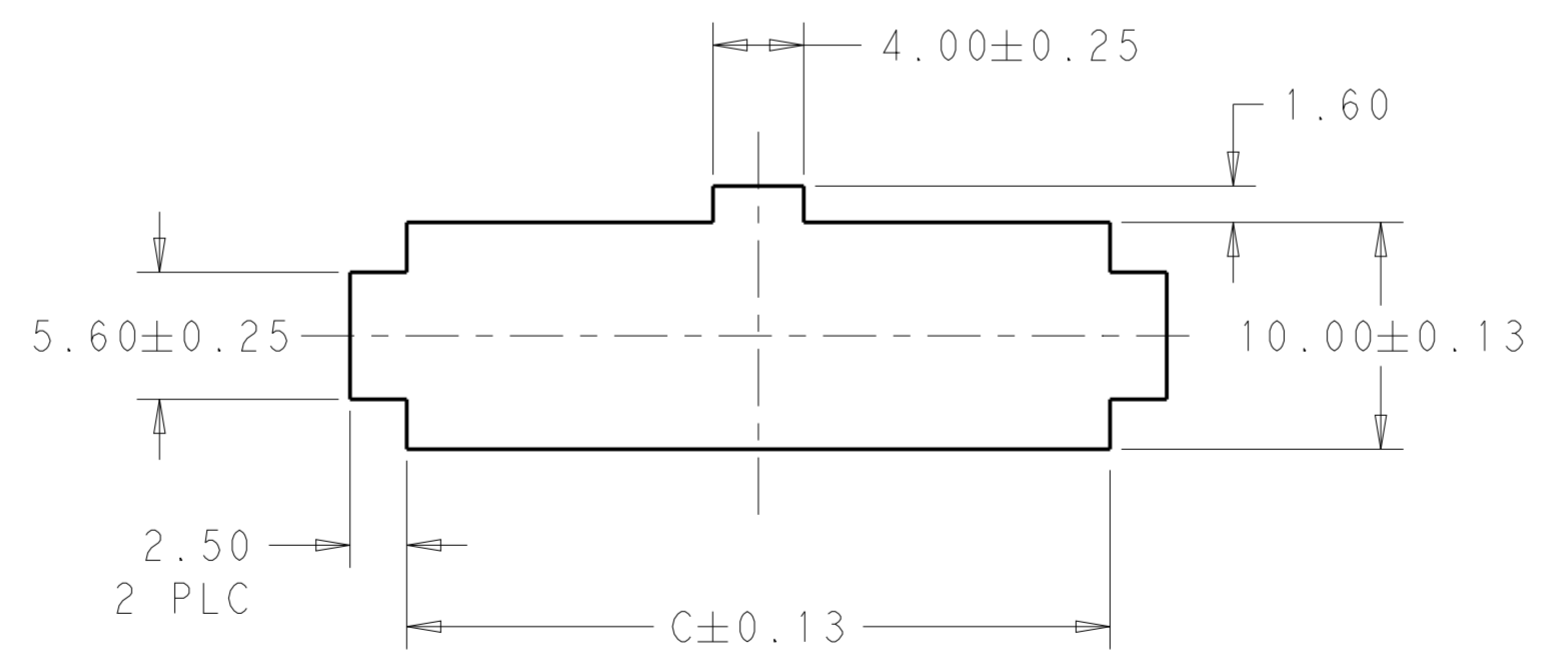
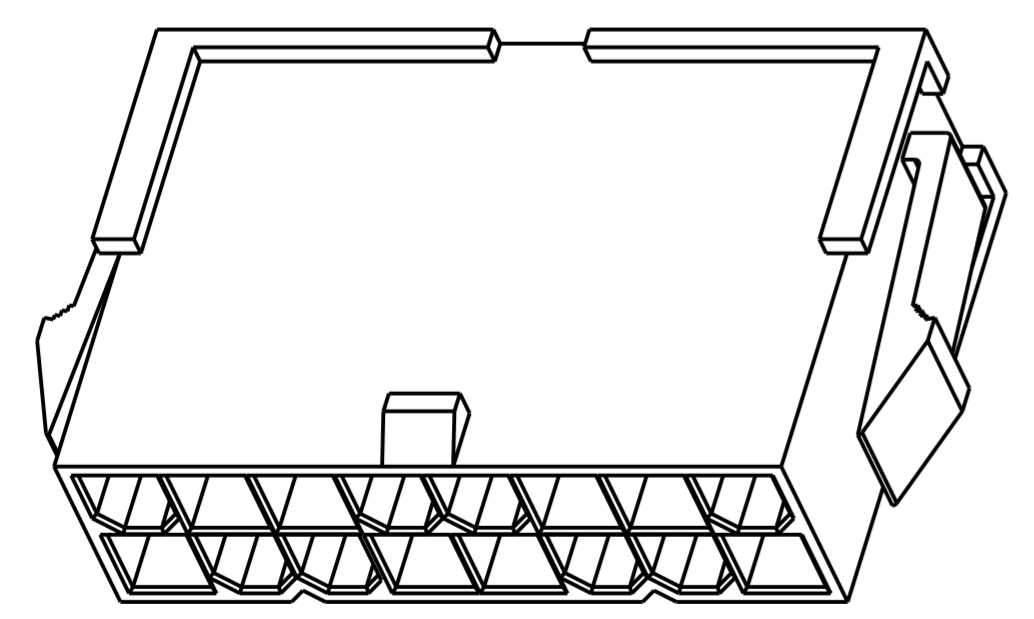
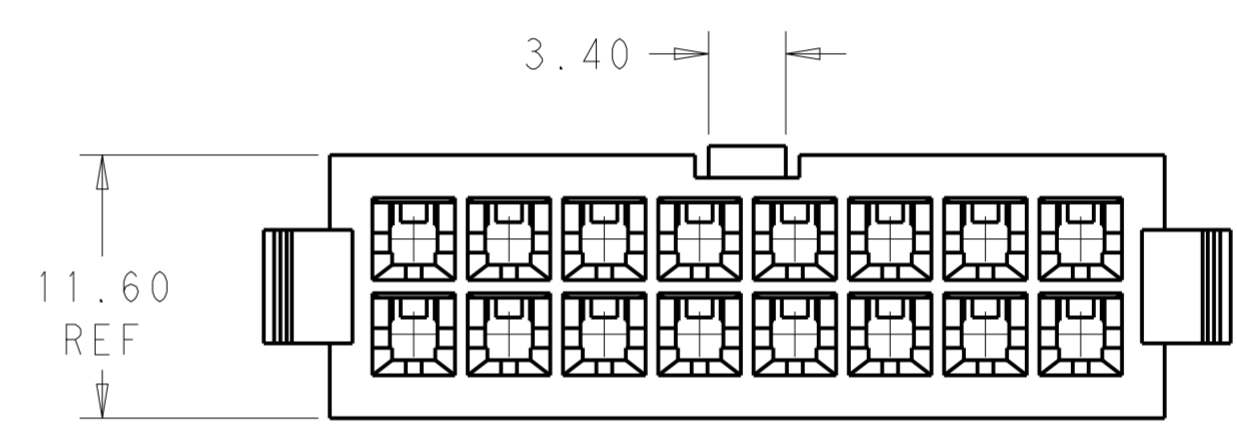
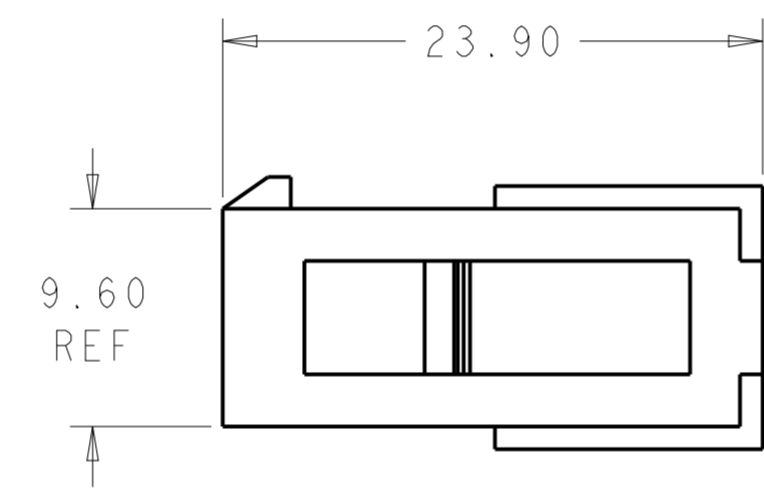
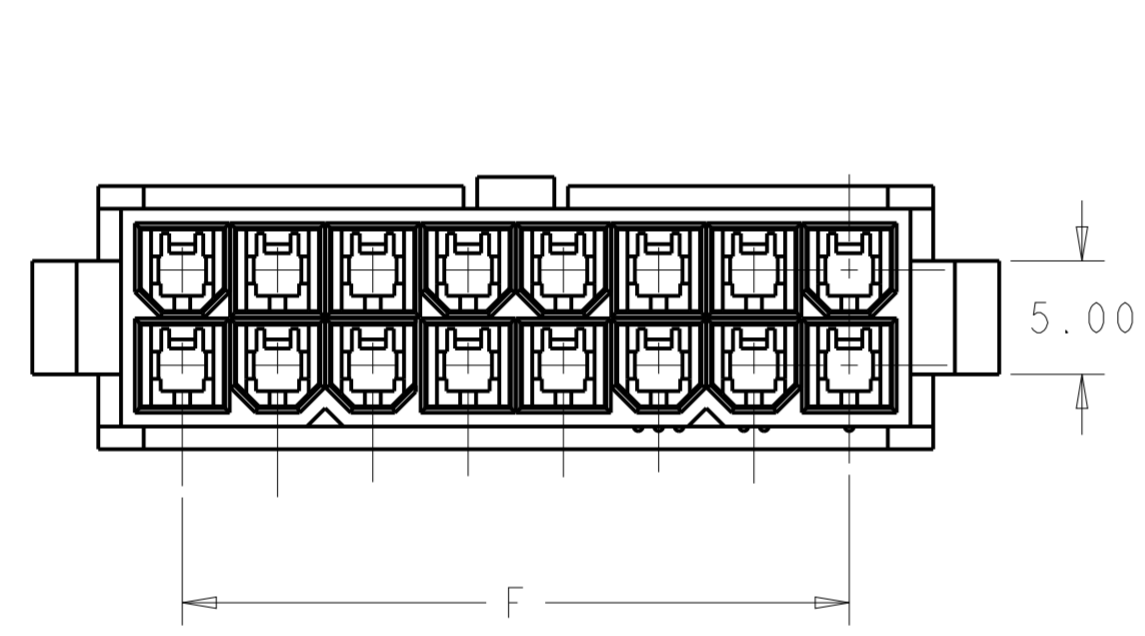

RECOMMENDED CUT-OUT FOR 2.00 MAX THICK PANEL

PANEL MUST BE PUNCHED OUT SO THAT THE HOUSING ENTERS THE PANEL IN THE SAME DIRECTION AS THE PUNCH.

52.00	46.2	51.60	24	2-1969605-4
47.80	42.0	47.40	22	2-1969605-2
43.60	37.8	43.20	20	2-1969605-0
39.40	33.6	39.00	18	1-1969605-8
35.20	29.4	34.80	16	1-1969605-6
31.00	25.2	30.60	14	1-1969605-4
26.80	21.0	26.40	12	1-1969605-2
22.60	16.8	22.20	10	1-1969605-0
18.40	12.6	18.00	8	1969605-8
14.20	8.4	13.80	6	1969605-6
10.00	4.2	9.60	4	1969605-4
5.80	--	5.40	2	1969605-2
DIM C	DIM F	DIM L	NO. OF POS	PART NO.

THIS DRAWING IS A CONTROLLED DOCUMENT.

DIMENSIONS: mm	TOLERANCES UNLESS OTHERWISE SPECIFIED:	DWN: JR RUTH 26SEPT13	 TE Connectivity
	0 PLC ±	CHK: KURT RANDOLPH 26SEPT13	
	1 PLC ±	APVD: KURT RANDOLPH 26SEPT13	
	2 PLC ±0.25	NAME: KURT RANDOLPH	
	3 PLC ±	PRODUCT SPEC: -	PANEL MOUNT PLUG HOUSING VAL-U-LOK, GLOW WIRE
	4 PLC ±	APPLICATION SPEC: -	SIZE: A200779
	ANGLES ±	WEIGHT: -	CAGE CODE: C-1969605
MATERIAL:	FINISH: ±	Customer Drawing	DRAWING NO: -
		SCALE: 3:1	RESTRICTED TO: -
		SHEET: 1 OF 1	REV: A1