

HiPerFET™ Power MOSFETs

IXFH 80N08
IXFT 80N08

$V_{DSS} = 80 \text{ V}$
 $I_{D25} = 80 \text{ A}$
 $R_{DS(on)} = 9 \text{ m}\Omega$

N-Channel Enhancement Mode
Avalanche Rated, High dv/dt

$t_{rr} \leq 200 \text{ ns}$

Preliminary data sheet



| Symbol | Test Conditions | Maximum Ratings | |
|---------------|---|-----------------|------------------|
| V_{DSS} | $T_J = 25^\circ\text{C}$ to 150°C | 80 | V |
| V_{DGR} | $T_J = 25^\circ\text{C}$ to 150°C ; $R_{GS} = 1 \text{ M}\Omega$ | 80 | V |
| V_{GS} | Continuous | ± 20 | V |
| V_{GSM} | Transient | ± 30 | V |
| I_{D25} | $T_C = 25^\circ\text{C}$ | 80 | A |
| $I_{L(RMS)}$ | Lead current limit | 75 | A |
| I_{DM} | $T_C = 25^\circ\text{C}$, pulse width limited by T_{JM} | 320 | A |
| I_{AR} | $T_C = 25^\circ\text{C}$ | 80 | A |
| E_{AR} | $T_C = 25^\circ\text{C}$ | 50 | mJ |
| E_{AS} | | 2.5 | J |
| dv/dt | $I_S \leq I_{DM}$, $di/dt \leq 100 \text{ A}/\mu\text{s}$, $V_{DD} \leq V_{DSS}$, $T_J \leq 150^\circ\text{C}$, $R_G = 2 \Omega$ | 5 | V/ns |
| P_D | $T_C = 25^\circ\text{C}$ | 300 | W |
| T_J | | -55 to +150 | $^\circ\text{C}$ |
| T_{JM} | | 150 | $^\circ\text{C}$ |
| T_{stg} | | -55 to +150 | $^\circ\text{C}$ |
| T_L | 1.6 mm (0.063 in) from case for 10 s | 300 | $^\circ\text{C}$ |
| M_d | Mounting torque | 1.13/10 | Nm/lb.in. |
| Weight | TO-247 | 6 | g |
| | TO-268 | 4 | g |

TO-247 AD (IXFH)

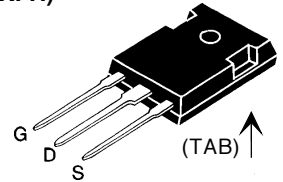

TO-268 (IXFT) Case Style

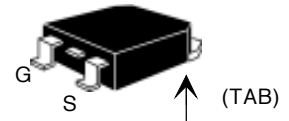

G = Gate D = Drain
S = Source TAB = Drain

| Symbol | Test Conditions | Characteristic Values ($T_J = 25^\circ\text{C}$, unless otherwise specified) | | |
|--------------|---|---|------|----------------------|
| | | min. | typ. | max. |
| V_{DSS} | $V_{GS} = 0 \text{ V}$, $I_D = 1 \text{ mA}$ | 80 | | V |
| $V_{GS(th)}$ | $V_{DS} = V_{GS}$, $I_D = 4 \text{ mA}$ | 2.0 | | V |
| I_{GSS} | $V_{GS} = \pm 20 \text{ V}_{DC}$, $V_{DS} = 0$ | | | $\pm 100 \text{ nA}$ |
| I_{DSS} | $V_{DS} = V_{DSS}$, $V_{GS} = 0 \text{ V}$ | $T_J = 25^\circ\text{C}$ | | 50 μA |
| | | $T_J = 125^\circ\text{C}$ | | 1 mA |
| $R_{DS(on)}$ | $V_{GS} = 10 \text{ V}$, $I_D = 0.5 I_{D25}$ Pulse test, $t \leq 300 \mu\text{s}$, duty cycle $d \leq 2\%$ | | | 9 m Ω |

Features

- International standard packages
- Low $R_{DS(on)}$
- Rated for unclamped Inductive load switching (UIS)
- Molding epoxies meet UL 94 V-0 flammability classification

Advantages

- Easy to mount
- Space savings
- High power density

| Symbol | Test Conditions | Characteristic Values ($T_J = 25^\circ\text{C}$, unless otherwise specified) | | |
|--------------|--|---|------|----------|
| | | min. | typ. | max. |
| g_{fs} | $V_{DS} = 10\text{ V}; I_D = 0.5 \cdot I_{D25}$, pulse test | 35 | 55 | S |
| C_{iss} | $V_{GS} = 0\text{ V}, V_{DS} = 25\text{ V}, f = 1\text{ MHz}$ | | 4800 | pF |
| C_{oss} | | | 1675 | pF |
| C_{rss} | | | 590 | pF |
| $t_{d(on)}$ | $V_{GS} = 10\text{ V}, V_{DS} = 0.5 \cdot V_{DSS}, I_D = 0.5 \cdot I_{D25}$ $R_G = 2.5\ \Omega$ (External), | | 50 | ns |
| t_r | | | 75 | ns |
| $t_{d(off)}$ | | | 95 | ns |
| t_f | | | 31 | ns |
| $Q_{g(on)}$ | $V_{GS} = 10\text{ V}, V_{DS} = 0.5 \cdot V_{DSS}, I_D = 0.5 \cdot I_{D25}$ | | 180 | nC |
| Q_{gs} | | | 42 | nC |
| Q_{gd} | | | 75 | nC |
| R_{thJC} | (TO-247) | | | 0.42 K/W |
| R_{thCK} | | | 0.25 | K/W |

| Symbol | Test Conditions | Characteristic Values ($T_J = 25^\circ\text{C}$, unless otherwise specified) | | |
|----------|---|---|------|---------------|
| | | min. | typ. | max. |
| I_S | $V_{GS} = 0\text{ V}$ | | 80 | A |
| I_{SM} | Repetitive; pulse width limited by T_{JM} | | 320 | A |
| V_{SD} | $I_F = I_S, V_{GS} = 0\text{ V}$, Pulse test, $t \leq 300\ \mu\text{s}$, duty cycle $d \leq 2\%$ | | 1.5 | V |
| t_{rr} | $I_F = 25\text{ A}, -di/dt = 100\text{ A}/\mu\text{s}, V_R = 25\text{ V}$ | | 0.5 | ns |
| Q_{RM} | | | 6 | μC |
| I_{RM} | | | | A |

TO-247 AD (IXFH) Outline

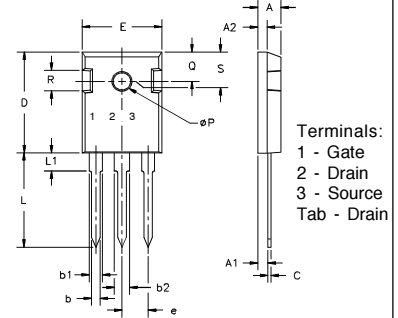

| Dim. | Millimeter | | Inches | |
|-----------------|------------|-------|--------|-------|
| | Min. | Max. | Min. | Max. |
| A | 4.7 | 5.3 | .185 | .209 |
| A ₁ | 2.2 | 2.54 | .087 | .102 |
| A ₂ | 2.2 | 2.6 | .059 | .098 |
| b | 1.0 | 1.4 | .040 | .055 |
| b ₁ | 1.65 | 2.13 | .065 | .084 |
| b ₂ | 2.87 | 3.12 | .113 | .123 |
| C | .4 | .8 | .016 | .031 |
| D | 20.80 | 21.46 | .819 | .845 |
| E | 15.75 | 16.26 | .610 | .640 |
| e | 5.20 | 5.72 | 0.205 | 0.225 |
| L | 19.81 | 20.32 | .780 | .800 |
| L ₁ | | 4.50 | | .177 |
| $\varnothing P$ | 3.55 | 3.65 | .140 | .144 |
| Q | 5.89 | 6.40 | 0.232 | 0.252 |
| R | 4.32 | 5.49 | .170 | .216 |
| S | 6.15 | BSC | .242 | BSC |

TO-268 Outline

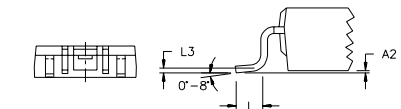
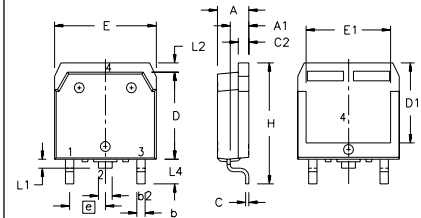

Terminals: 1 - Gate 2 - Drain
3 - Source Tab - Drain

| SYM | INCHES | | MILLIMETERS | |
|----------------|--------|----------|-------------|----------|
| | MIN | MAX | MIN | MAX |
| A | .193 | .201 | 4.90 | 5.10 |
| A ₁ | .106 | .114 | 2.70 | 2.90 |
| A ₂ | .001 | .010 | 0.02 | 0.25 |
| b | .045 | .057 | 1.15 | 1.45 |
| b ₂ | .075 | .083 | 1.90 | 2.10 |
| C | .016 | .026 | 0.40 | 0.65 |
| C ₂ | .057 | .063 | 1.45 | 1.60 |
| D | .543 | .551 | 13.80 | 14.00 |
| D ₁ | .488 | .500 | 12.40 | 12.70 |
| E | .624 | .632 | 15.85 | 16.05 |
| E ₁ | .524 | .535 | 13.30 | 13.60 |
| e | | .215 BSC | | 5.45 BSC |
| H | .736 | .752 | 18.70 | 19.10 |
| L | .094 | .106 | 2.40 | 2.70 |
| L ₁ | .047 | .055 | 1.20 | 1.40 |
| L ₂ | .039 | .045 | 1.00 | 1.15 |
| L ₃ | .010 | BSC | 0.25 | BSC |
| L ₄ | .150 | .161 | 3.80 | 4.10 |

IXYS reserves the right to change limits, test conditions, and dimensions.

IXYS MOSFETS and IGBTs are covered by one or more of the following U.S. patents: 4,835,592 4,881,106 5,017,508 5,049,961 5,187,117 5,486,715
4,850,072 4,931,844 5,034,796 5,063,307 5,237,481 5,381,025