

Description

The AH9485 and AH9486 are single chip solutions for driving a single phase (coil) brushless DC motors. It integrates the motor driver and the high sensitivity Hall effect sensor to simplify the system circuit and PCB design for simpler solutions.

Rotor lock-detect, shutdown and auto-restart functions help to prevent the motor from over-heating when rotor is locked and restarts the motor after the lock is removed.

The AH9485 and AH9486 have built-in open drain tachometer frequency generator (FG) and rotation detection (RD) outputs to allow external interface to monitor motor rotation, speed or rotor locks conditions easily. The FG provides magnetic change frequency while the RD provides the rotor status.

The full bridge output stage uses "soft-switching" technique to minimize the audible switching noise (vibration and acoustic noise) and electromagnetic interference (EMI) providing a low noise solution.

Over-temperature shutdown provides thermal protection for the device. An external DC voltage or a PWM (pulse-width modulation) signal on the PWM pin can be used to control the motor speed.

The AH9485 and AH9486 are packaged in TSOT26F.

Features

- Internal Full Bridge Driver
- High Sensitivity Integrated Hall Sensor
- Low and Wide Supply Voltage Range of 2V to 6V
- Soft Switching for Low Noise
- Rotor Lock Protection and Auto-Restart
- DC Voltage or PWM Signal Speed Control
- Thermal Protection
- Tachometer FG Output(AH9485) or Rotor Lock Alarm RD Output (AH9486)
- Operating Temperature Range of -40°C to +105°C
- Flat Pin TSOT26F Package
- **Totally Lead-Free & Fully RoHS Compliant (Notes 1 & 2)**
- **Halogen and Antimony Free. "Green" Device (Note 3)**

- Notes:
1. No purposely added lead. Fully EU Directive 2002/95/EC (RoHS) & 2011/65/EU (RoHS 2) compliant.
 2. See http://www.diodes.com/quality/lead_free.html for more information about Diodes Incorporated's definitions of Halogen- and Antimony-free, "Green" and Lead-free.
 3. Halogen- and Antimony-free "Green" products are defined as those which contain <900ppm bromine, <900ppm chlorine (<1500ppm total Br + Cl) and <1000ppm antimony compounds.

Pin Assignments

(Top View)

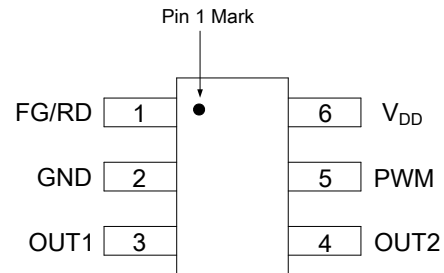

TSOT26F

Applications

- 5V Low Noise BLDC Cooling Fans
- Low Voltage / Low Power BLDC Motors
- Notebook / VGA DC Fans / Blowers
- Micro-Motors

Typical Applications Circuit (Note 4)

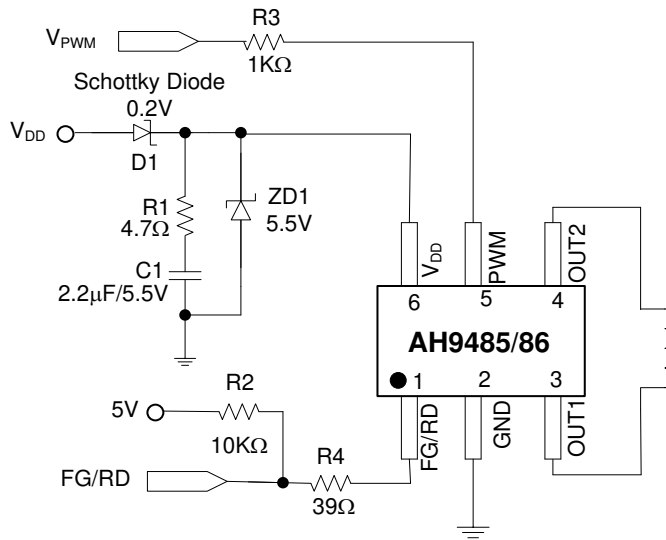

Note 4: Must use C1 capacitor for the decoupling between V_{DD} and GND and place the capacitor as close to the IC as possible.
 ZD1: V_{DD} over-voltage stress protection diode.
 R2: current limit resistor for Open Drain RD output.
 R3: de-coupling resistor for long-distance signal transmission.

Pin Descriptions

Pin Number	Pin Name	Function
1	FG/RD	FG(AH9485) or RD(AH9486)
2	GND	Ground pin
3	OUT1	Output pin 1
4	OUT2	Output pin 2
5	PWM	DC voltage or Pulse width modulation signal speed control pin
6	V _{DD}	Power supply pin

NEW PRODUCT

Functional Block Diagram

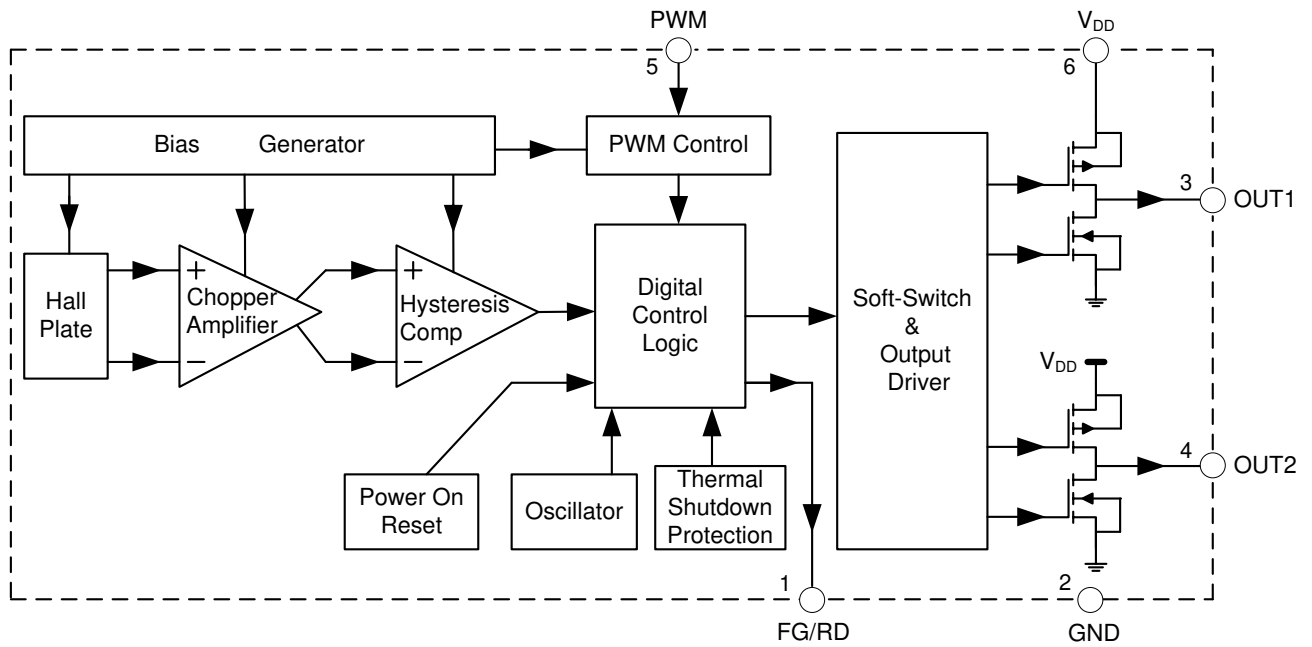

NEW PRODUCT

Absolute Maximum Ratings (Notes 5 and 6) (@ $T_A=+25^{\circ}\text{C}$, unless otherwise specified.)

Symbol	Parameter	Rating	Unit
V_{DD}	Supply Voltage	7	V
I_{OUTP}	Peak Output Current	500	mA
I_{OUTC}	Continuous Output Current	300	mA
$V_{FG/RD}$	FG/RD Pull-up Voltage	7 or V_{DD}	V
$I_{FG/RD}$	FG/RD Current	20	mA
P_D	Power Dissipation	520	mW
θ_{JA}	Thermal Resistance (Junction to Ambient)	141	$^{\circ}\text{C}/\text{W}$
T_{STG}	Storage Temperature	-55 to +150	$^{\circ}\text{C}$
ESD	ESD (Human Body Model) (Note 7)	2000	V

- Note:
- Stresses greater than those listed under "Absolute Maximum Ratings" may cause permanent damage to the device. These are stress ratings only, and functional operation of the device at these or any other conditions beyond those indicated under "Recommended Operating Conditions" is not implied. Exposure to "Absolute Maximum Ratings" for extended periods may affect device reliability.
 - The absolute maximum V_{DD} of 7V is a transient stress rating and is not meant as a functional operating condition. It is not recommended to operate the device at the absolute maximum rated conditions for any period of time.
 - Electronic semiconductor products are sensitive to Electro Static Discharge (ESD). Always observe Electro Static Discharge control procedures whenever handling semiconductor products.

Recommended Operating Conditions

Symbol	Parameter	Min	Max	Unit
V_{DD}	Supply Voltage	2	6	V
T_A	Ambient Temperature	-40	+105	$^{\circ}\text{C}$

Electrical Characteristics (@ $V_{DD} = 5\text{V}$, $T_A=+25^{\circ}\text{C}$, unless otherwise specified.)

Symbol	Parameter	Conditions	Min	Typ	Max	Unit
I_{DD}	Supply Current	–	–	1.8	3	mA
$R_{DS(ON)1}$	ON Resistance ($R_{PMOS}+R_{NMOS}$)	$I_{OUT} = 300\text{mA}$	–	2	–	Ω
$R_{DS(ON)2}$	OUT1, OUT2 ON Resistance	$T_J = +125^{\circ}\text{C}$, $I_{OUT} = 300\text{mA}$	–	3	–	Ω
V_{OL}	FG/RD Output Low Voltage	$I_{OL} = 10\text{mA}$	–	0.33	0.5	V
I_{LEAK}	FG/RD Output Leakage Current	$V_{FG}(V_{RD}) = 5\text{V}$	–	0.15	10	μA
t_{ON}	Locked Rotor Period	–	–	0.25	–	s
t_{OFF}		–	–	1.5	–	s
PWM_{HIGH}	PWM Voltage Range	–	$>0.5 \times V_{DD}$	–	V_{DD}	V
PWM_{LOW}		–	0	–	$<0.14 \times V_{DD}$	V

Magnetic Characteristics (@ $V_{DD} = 5V$, $T_A = +25^\circ C$, unless otherwise specified.)

Symbol	Parameter	Min	Typ	Max	Unit
B_{OP}	Operating Point	0	25	50	Gauss
B_{RP}	Releasing Point	-50	-25	0	Gauss
B_{HYS}	Hysteresis	-	50	-	Gauss

Magnetic Hysteresis Characteristics

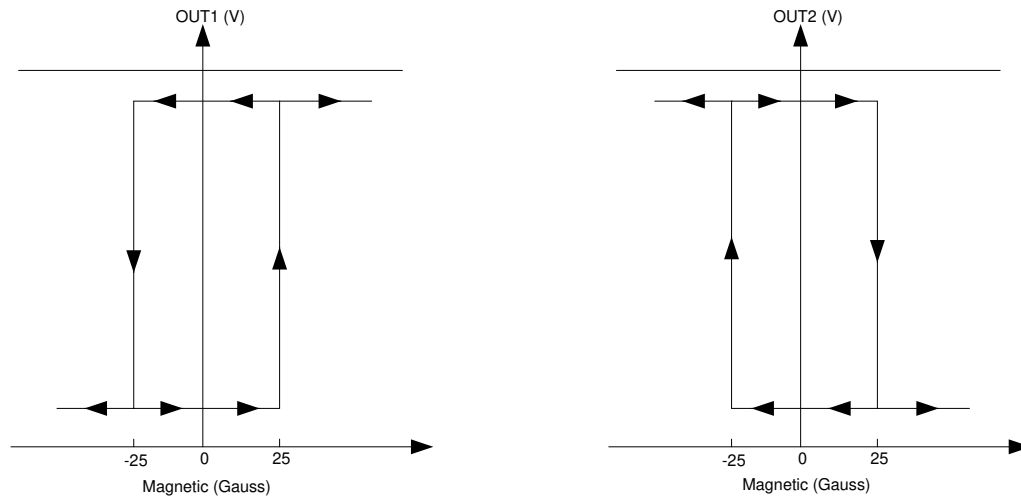

OUT1 Output vs. Magnetism

OUT2 Output vs. Magnetism

Output Waveforms Description (Notes 8 and 9)

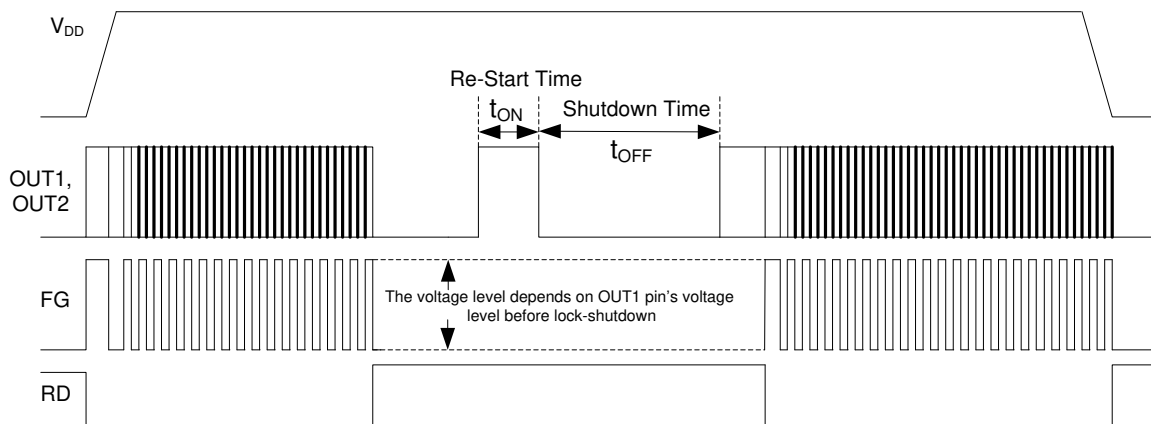

- Notes:
- 8. RD and FG are open drain outputs and the high level of the signal depends on the external supply voltage.
 - 9. The on torque time of motor is same as the re-start time.

Test Circuit

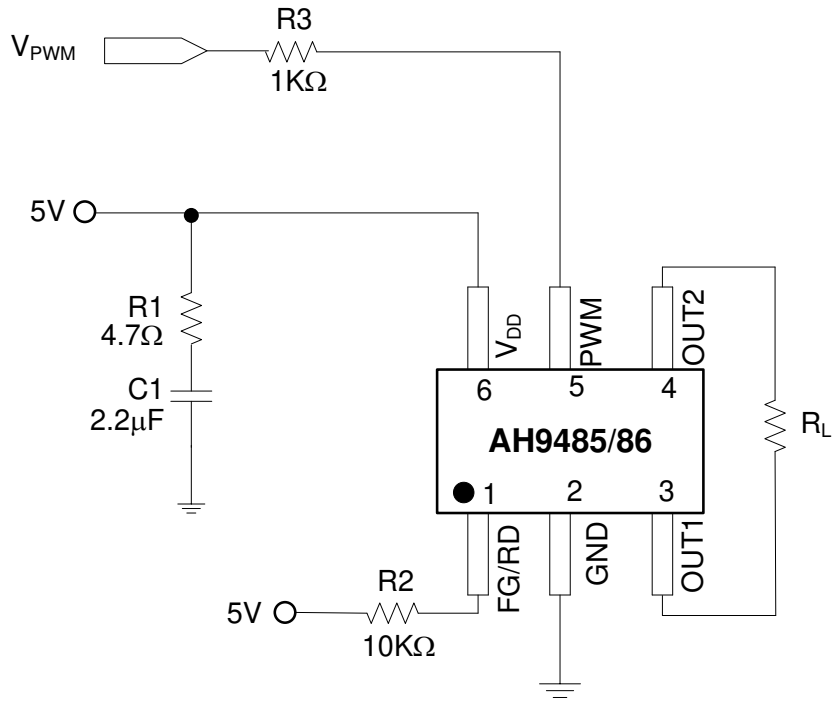

NEW PRODUCT

Application Note (Notes 10, 11 and 12)

DC Supply Voltage Speed Control

Motor speed can be controlled by varying the V_{DD} supply voltage while PWM pin is tied to V_{DD} pin.

PWM Pin Speed Control

PWM (pulse width modulation) pin can be used to control the motor speed. There are two types of speed control using PWM pin:

- a) DC Voltage Mode
- b) Pulse Width Mode

a) DC Voltage Mode PWM:

DC voltage signal (V_{PWM}) on the PWM pin can be used to control the motor speed. Applying a DC voltage to the PWM pin will generate an internal PWM pulses with the "ON" duty cycle based on the applied DC voltage according to the diagram below. The internal duty ratio generated will change from 0% duty at $V_{PWM} = 0.14V_{DD}$ typically to 100% at $V_{PWM} = 0.5V_{DD}$.

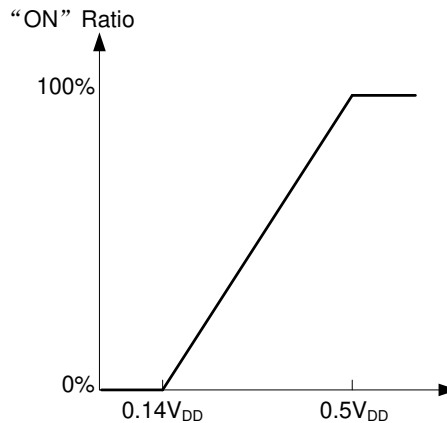

- Notes:
- 10. While using pulse mode PWM, the "High" value of the input pulse should be higher than $0.5 \times V_{DD}$ and the "Low" value should be lower than $0.14 \times V_{DD}$.
 - 11. The lower-limit for the PWM pulse frequency is 200Hz, and the recommended frequency range is higher than 30kHz where the PWM input pulses will not generate acoustic noise.
 - 12. The "PWM" pin contains an internal pull-up resistor, so the AH9485/86 will rotate at full-speed (100% ON) when this pin is left un-connected (floating).

b) Pulse Mode PWM:

External PWM pulses can be applied directly to the PWM pin to control the speed. The AH9485/86 will pass this pulse to the coil driver with the original duty-cycle ratio. While using pulse mode PWM, the "High" value of the input pulse should be higher than $0.5 \times V_{DD}$ and the "Low" value should be lower than $0.14 \times V_{DD}$. The lower-limit for the PWM pulse frequency is 200Hz, and the recommended frequency range is higher than 30kHz to help prevent acoustic noise related to the switching.

Soft Switching

AH9485/86 use soft switching of the motor coil current during commutation to minimize audible switching noise and electromagnetic Interference (EMI) to provide a low noise solution.

Performance Characteristics

NEW PRODUCT

Supply Current I_{DD} vs. Supply Voltage V_{DD}

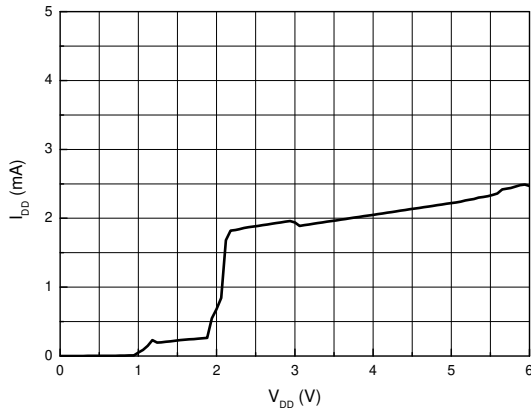

Supply Current I_{DD} vs. Operating Temperature T_A

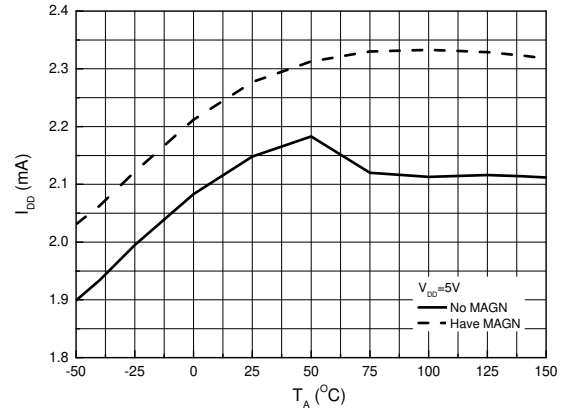

Operating Switch Points B_{OP} , B_{RP} & B_{HYS} vs. Supply Voltage V_{DD}

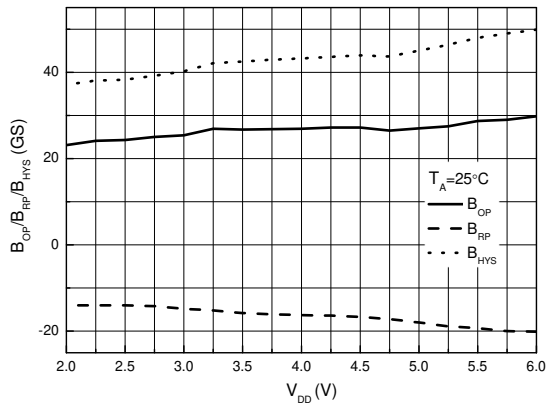

Operating Switch Points B_{OP} , B_{RP} & B_{HYS} vs. Operating Temperature T_A

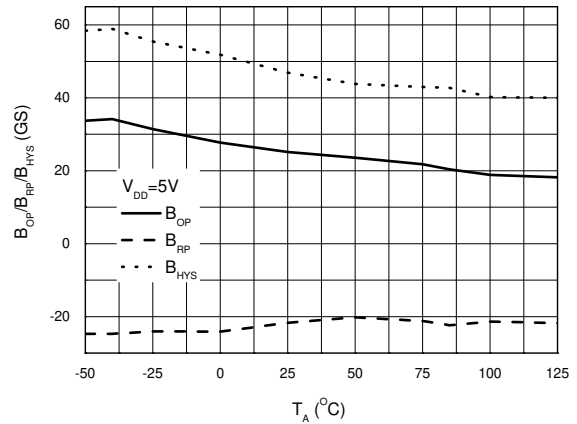

High+Low Side $R_{DS(ON)}$ vs. Supply Voltage V_{DD}

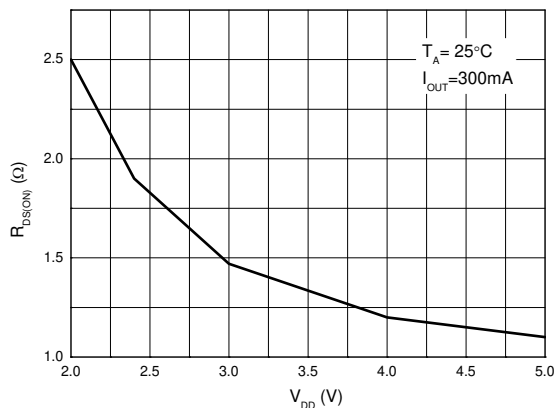

High+Low Side $R_{DS(ON)}$ vs. Operating Temperature T_A

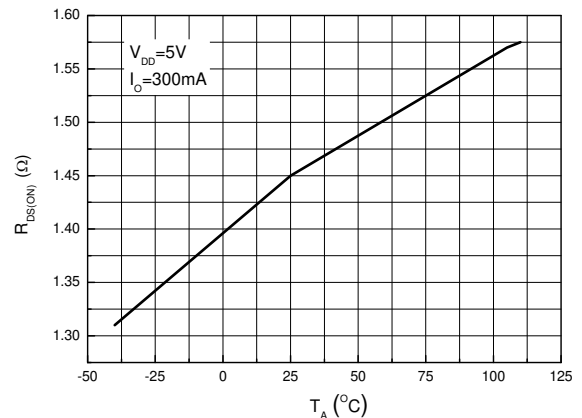

Ordering Information

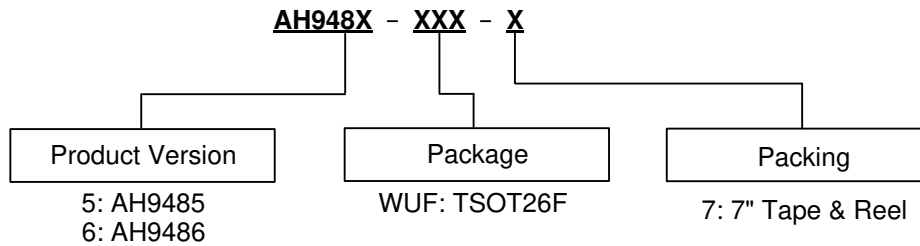

Part Number	Package Code	Packaging	7" Tape and Reel	
			Quantity	Part Number Suffix
AH9485-WUF-7	WUF	TSOT26F	3000/Tape & Reel	-7
AH9486-WUF-7	WUF	TSOT26F	3000/Tape & Reel	-7

Marking Information

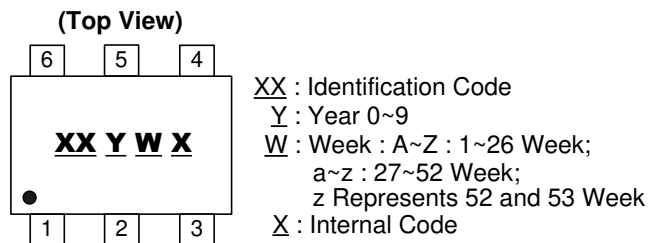

Part Number	Package	Identification Code
AH9485-WUF-7	TSOT26F	H5
AH9486-WUF-7	TSOT26F	H6

NEW PRODUCT

Package Outline Dimensions (All dimensions in mm.)

Please see AP02002 at <http://www.diodes.com/datasheets/ap02002.pdf> for the latest version.

(1) Package Type: TSOT26F

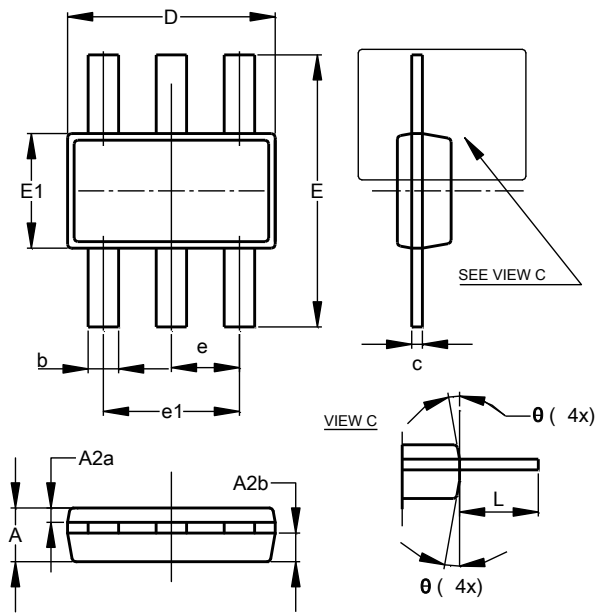

TSOT26F			
Dim	Min	Max	Typ
A	0.700	0.800	0.750
A2a	0.325	0.375	0.350
A2b	0.375	0.425	0.400
b	0.425	0.475	0.450
c	0.150	0.200	0.175
D	2.850	2.950	2.900
E	3.750	3.850	3.800
E1	1.550	1.650	1.600
e	0.950 BSC		
e1	1.900 BSC		
L	1.100 BSC		
θ	4°	12°	10°
All Dimensions in mm			

NEW PRODUCT

Min/Max(in mm)

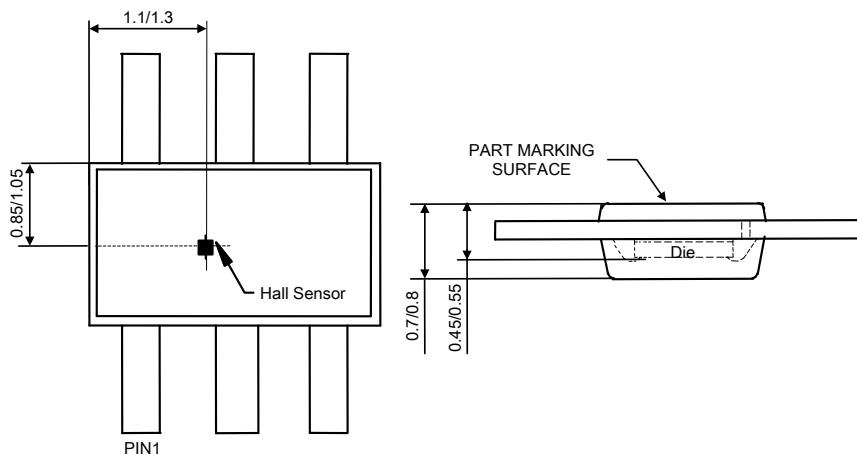

Sensor Location

Mechanical Structure

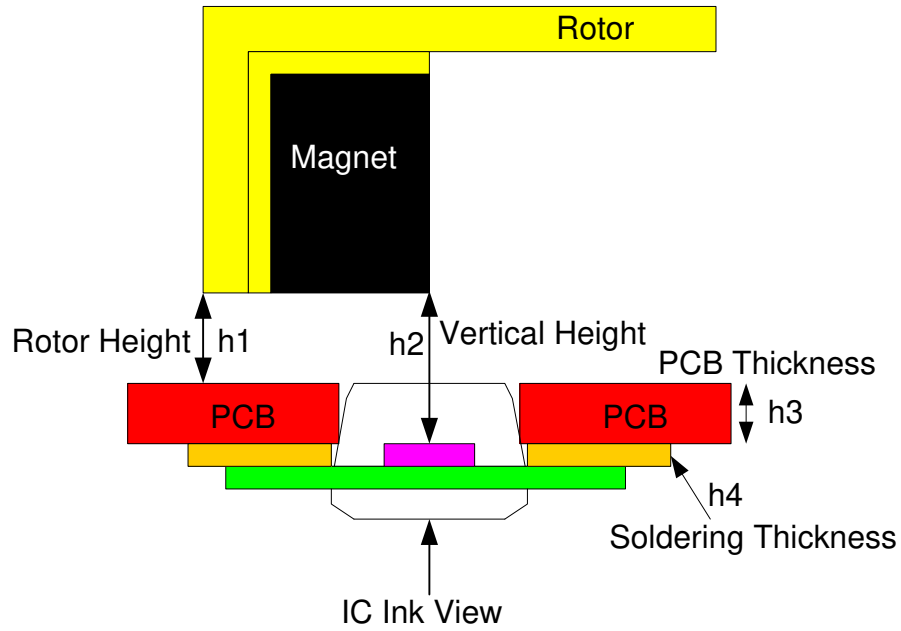

Suggested Pad Layout

Please see AP02001 at <http://www.diodes.com/datasheets/ap02001.pdf> for the latest version.

(1) Package Type: TSOT26F

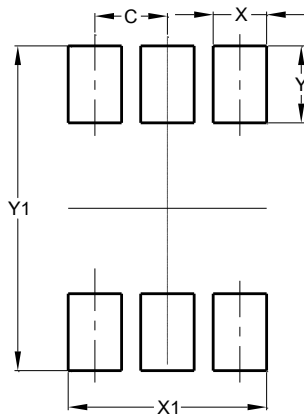

Dimensions	Value (in mm)
C	0.950
X	0.700
X1	2.600
Y	1.000
Y1	4.220

IMPORTANT NOTICE

DIODES INCORPORATED MAKES NO WARRANTY OF ANY KIND, EXPRESS OR IMPLIED, WITH REGARDS TO THIS DOCUMENT, INCLUDING, BUT NOT LIMITED TO, THE IMPLIED WARRANTIES OF MERCHANTABILITY AND FITNESS FOR A PARTICULAR PURPOSE (AND THEIR EQUIVALENTS UNDER THE LAWS OF ANY JURISDICTION).

Diodes Incorporated and its subsidiaries reserve the right to make modifications, enhancements, improvements, corrections or other changes without further notice to this document and any product described herein. Diodes Incorporated does not assume any liability arising out of the application or use of this document or any product described herein; neither does Diodes Incorporated convey any license under its patent or trademark rights, nor the rights of others. Any Customer or user of this document or products described herein in such applications shall assume all risks of such use and will agree to hold Diodes Incorporated and all the companies whose products are represented on Diodes Incorporated website, harmless against all damages.

Diodes Incorporated does not warrant or accept any liability whatsoever in respect of any products purchased through unauthorized sales channel. Should Customers purchase or use Diodes Incorporated products for any unintended or unauthorized application, Customers shall indemnify and hold Diodes Incorporated and its representatives harmless against all claims, damages, expenses, and attorney fees arising out of, directly or indirectly, any claim of personal injury or death associated with such unintended or unauthorized application.

Products described herein may be covered by one or more United States, international or foreign patents pending. Product names and markings noted herein may also be covered by one or more United States, international or foreign trademarks.

This document is written in English but may be translated into multiple languages for reference. Only the English version of this document is the final and determinative format released by Diodes Incorporated.

LIFE SUPPORT

Diodes Incorporated products are specifically not authorized for use as critical components in life support devices or systems without the express written approval of the Chief Executive Officer of Diodes Incorporated. As used herein:

A. Life support devices or systems are devices or systems which:

1. are intended to implant into the body, or
2. support or sustain life and whose failure to perform when properly used in accordance with instructions for use provided in the labeling can be reasonably expected to result in significant injury to the user.

B. A critical component is any component in a life support device or system whose failure to perform can be reasonably expected to cause the failure of the life support device or to affect its safety or effectiveness.

Customers represent that they have all necessary expertise in the safety and regulatory ramifications of their life support devices or systems, and acknowledge and agree that they are solely responsible for all legal, regulatory and safety-related requirements concerning their products and any use of Diodes Incorporated products in such safety-critical, life support devices or systems, notwithstanding any devices- or systems-related information or support that may be provided by Diodes Incorporated. Further, Customers must fully indemnify Diodes Incorporated and its representatives against any damages arising out of the use of Diodes Incorporated products in such safety-critical, life support devices or systems.

Copyright © 2015, Diodes Incorporated

www.diodes.com