

## **OPA547EVM, OPA548EVM**

---

---

---

This user's guide describes the characteristics, operation and use of the [OPA547](#) and [OPA548](#) evaluation module (EVM). This guide discusses how to set up and configure the board hardware, and describes various applications using the evaluation module. Throughout this document the terms *evaluation board*, *evaluation module*, and *EVM* are synonymous with the *OPA547EVM*, *OPA548EVM*. This document also includes an electrical schematic, a printed circuit board (PCB) layout drawing, and a parts list for the EVM.

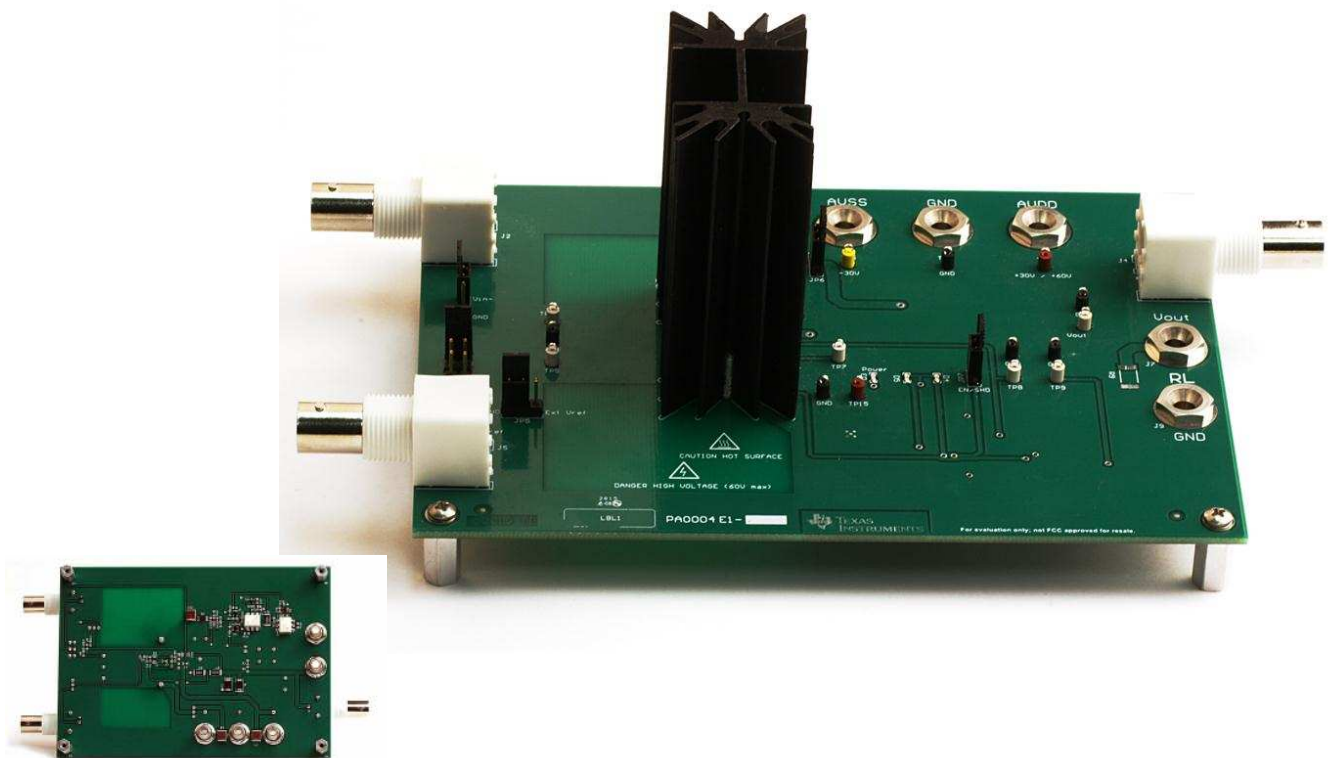

**OPA547, OPA548 Evaluation Module (EVM)**

## OPA547, OPA548 Evaluation Module (EVM) (continued)

### Contents

1	Overview .....	3
	1.1 General Overview of the OPA547 and OPA548 .....	3
	1.2 Safety First! .....	3
	1.3 General Overview of the OPA547EVM and OPA548EVM .....	3
	1.4 Supply Voltage Consideration for Using the OPA547EVM, OPA548EVM .....	4
	1.5 Related Documentation from Texas Instruments .....	4
	1.6 Jumpers .....	5
	1.7 LEDs .....	5
2	Schematics and Layout .....	6
	2.1 Schematics .....	6
	2.2 Layout .....	6
3	Getting Started .....	8
	3.1 Power Supply .....	8
	3.2 Inputs .....	9
	3.3 Outputs .....	9
	3.4 Enable, Disable Feature .....	9
	3.5 Current Limitation Capability .....	9
4	Noninverting Amplifier Configuration Setup .....	10
5	Inverting Amplifier Configuration Setup .....	12
6	Differential Amplifier Configuration Setup .....	14
7	Improved Howland Current Pump Configuration Setup .....	16
8	Appendix .....	18
	8.1 Bill of Materials .....	19

### List of Figures

1	OPA547, OPA548 EVM Schematics .....	6
2	OPA547EVM, OPA548EVM Top Layer .....	7
3	OPA547EVM, OPA548EVM Bottom Layer .....	8
4	Noninverting Amplifier Configuration Schematic .....	10
5	Noninverting Operation .....	11
6	Inverting Amplifier Configuration Schematic .....	12
7	Inverting Operation .....	13
8	Differential Amplifier Configuration Schematic .....	14
9	Differential Operation .....	15
10	Improved Howland Current Pump Schematic .....	16
11	Improved Howland Current Pump Operation .....	17
12	Complete OPA547EVM, OPA548EVM Schematics .....	18

### List of Tables

1	Related Documentation .....	4
2	Basic Jumper Functions .....	5
3	Status of the LEDs .....	5
4	Noninverting Configuration .....	10
5	Inverting Configuration .....	12
6	Differential Configuration .....	14
7	Improved Howland Current Pump Configuration .....	16
8	Bill of Materials .....	19

## 1 Overview

### 1.1 General Overview of the OPA547 and OPA548

The OPA547 and OPA548 are high-voltage, high-current, operational amplifiers (op amps) useable for a wide range of industrial and commercial applications. These devices are functionally similar to low-power operational amplifiers, but with the added ability to provide amperes of output current and an output voltage swing in excess of 50 V. Added adjustable current limit capability, thermal shutdown, and enable and shutdown features provide protection and versatility in their use.

### 1.2 Safety First!

The OPA547 and OPA548 op amps can use a power-supply voltage as great as 60 V in single-supply connection, or  $\pm 30$  V in dual-supply connection, both of which represent a potential difference of 60 V. The possibility for accidental electrical shock increases with the increased potential difference and the user must take precautions to avoid contact with the PCB when live voltage is present. If circuit probing is required and voltages are present, a best practice is to apply the *one hand rule*. Use an insulated probe and only one hand when probing the live circuit. Keep the other hand away from the circuit and any metal contacts in the immediate area through which current can flow.

Power op amps can generate a lot of heat under certain operating conditions. This excess heat must be conducted away from the amplifier in order to ensure correct operation and long life. A passive heat sink, or heat sink and fan assembly, may be employed. Heat sinks can become hot to the touch if the power being dissipated as heat is high relative to the dissipation quantity of the heat sink. When the heat sink becomes hot, any contact with the heat sink can startle the user, or possibly result in the user receiving a mild burn. Therefore, avoiding any contact with the heat sink is best when the circuit is in use, or during cool down after use.

### 1.3 General Overview of the OPA547EVM and OPA548EVM

This product-unique evaluation module (EVM), developed for the OPA547, OPA548, allows users to more easily evaluate design concepts. This EVM is easily configured as a noninverting, inverting, or difference amplifier, or as an improved Howland current pump. This guide discusses many applications for the OPA547 and OPA548 devices.

This EVM is based on a 6.0-inch  $\times$  4.25-inch (15.2 cm  $\times$  10.8 cm) PCB that accommodates the 7-lead, stagger-formed, TO-220 package.

Because the OPA547 and OPA548 can be operated with either a single supply ( $V_+$  and ground), or dual supplies ( $V_+$  and  $V_-$ ), the EVM is designed to be used with either arrangement. A jumper (JP6) sets the supply arrangement. Three LEDs (green, yellow, and red) indicate EVM functionality. A green LED illuminates when  $V_+$  is applied. The enable and shutdown function and thermal shutdown indicator are functional with either supply arrangement. A red LED illuminates when the amplifier is in thermal shutdown mode (for approximately 10  $\mu$ s or longer), and both the red and yellow LEDs illuminate when the amplifier is set to shutdown mode (through jumper JP7). Shutdown mode is a low current, output disabled mode. During normal operation, the yellow and red LEDs are off.

A heat sink is provided with the board for low- and medium-power circuits, but may be removed and replaced with a user-provided heat sink for higher power applications. The PCB area between the OPA547 or OPA548 heat sink and input jacks J5 and J2 is free of components, so that a different heat sink may be used, if desired. The provided heat sink must be removed if a different heat sink is used. Additionally, if new drill holes are required, only use the isolated area of the PCB to drill any new holes in order to avoid short circuits.

Be aware of the fact that the two mounting pins of the provided heat sink are connected through vias to the negative supply ( $V_{SS}$ ), thus eliminating the need for isolation between the heat sink and the device.

## 1.4 Supply Voltage Consideration for Using the OPA547EVM, OPA548EVM

Some minor compromises are necessary to provide maximum usage of the OPA547EVM, OPA548EVM. Having one EVM that can accommodate both single and dual supplies places a limitation on the lowest supply voltage that can be used in dual-supply mode.

The OPA547EVM, OPA548EVM is designed to be powered by the user's single or dual, high-current, high-voltage power supply. The [TPS7A4001](#) (a high, wide voltage range, 5-V regulator) is included on the PCB to eliminate the need for a separate, low-voltage supply. Because the OPA547 and OPA548 can be powered with as little as  $\pm 4$  V,  $V_+$  is not high enough to fully power the regulator. Therefore, TI recommends that the minimum  $V_+$  level should be 6.0 V when using dual supplies. Note that the EVM can be used with a  $\pm 4$ -V dual supply, but the shutdown and enable function and thermal indicator LED may not operate properly.

With a single negative supply (such as 0 V and  $-30$  V), none of the LEDs illuminate and the disable function provided by JP4 no longer functions. If required, the OPA547, OPA548 can be disabled by carefully connecting the test points TP E/S to TP8 or Avss, through an insulated wire.

## 1.5 Related Documentation from Texas Instruments

[Table 1](#) provides information about related TI documentation.

The following documents provide information regarding Texas Instruments' integrated circuits used in the assembly of the OPA547EVM, OPA548EVM. This user's guide is available from the TI web site under literature number SBOU132. Any letter appended to the literature number corresponds to the document revision that is current at the time of the writing of this document. Newer revisions may be available from the [TI web site](#), or call the Texas Instruments' Literature Response Center at (800) 477-8924 or the Product Information Center at (972) 644-5580. When ordering, identify the document by both title and literature number.

**Table 1. Related Documentation**

Document	Literature Number
OPA547 product data sheet	<a href="#">SBOS056</a>
OPA548 product data sheet	<a href="#">SBOS070</a>
<i>A Comprehensive Study of the Howland Current Pump</i> application note	<a href="#">SNOA474</a>

## 1.6 Jumpers

A brief description of the basic jumper functions is shown in [Table 2](#). More information can be found in [Section 3](#).

**Table 2. Basic Jumper Functions**

Jumper	Description
JP1	Selects the signal presented to the amplifier Vin– pin
JP2, JP3, JP4	Selects the signal presented to the amplifier Vin+ pin
JP5	Selects the reference voltage to the amplifier positive input (GND or external Vref)
JP6	Selects single or dual supply
JP7	Disables or enables the OPA547, OPA548 output

## 1.7 LEDs

[Table 3](#) describes the status of the LEDs during illumination. More details can be found in [Section 3](#).

**Table 3. Status of the LEDs**

LED(s)	Description
Green	A positive power supply is present
Red <sup>(1)</sup>	The device is in thermal shutdown mode <sup>(1)</sup>
Red + Yellow	The device is in shutdown mode

<sup>(1)</sup> When using a heat sink, the time that the device is in thermal shutdown mode may not be long enough to switch on the red LED. Thus, TI recommends observing the status of E/S when using a heat sink.

## 2 Schematics and Layout

### 2.1 Schematics

Figure 1 shows the EVM amplifier main circuitry. The complete schematic of the EVM, including the enable and shutdown and LED circuits, can be found in Section 8, Figure 12.

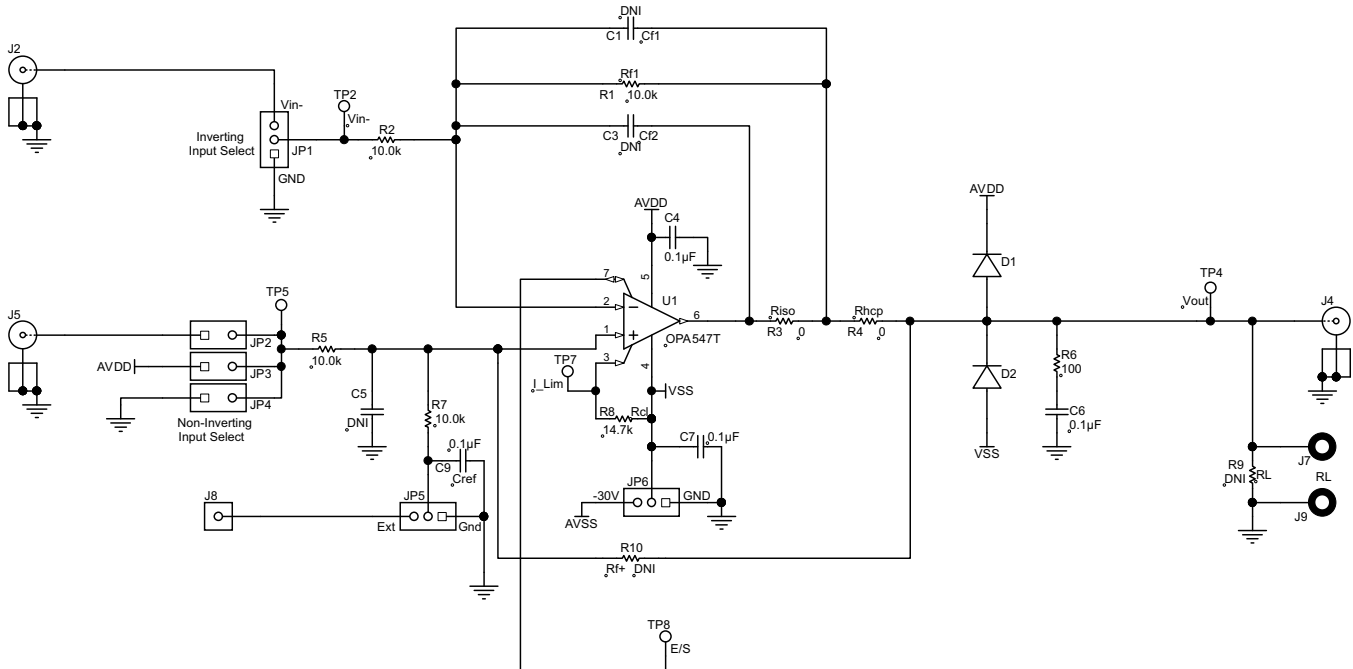

Figure 1. OPA547, OPA548 EVM Schematics

### 2.2 Layout

The EVM top and bottom layers are illustrated in Figure 2 and Figure 3, respectively.

Rf1, Cf1, Cf2, and Rf+ are the user-selectable op amp feedback components. Rcl is the output current-limiting resistor. The Riso and Rhcp board locations can be used to place an isolation resistor to improve stability and to set the output current if the OPA547, OPA548 are configured as an improved Howland current pump (see Section 7). By default, Riso and Rhcp are 0  $\Omega$ . Note that setting Riso and Rhcp greater than 0  $\Omega$  creates a low-pass filter with the output compensation consisting of R7 and C8.

There are three banana jacks that supply power to the EVM (see Section 3.2) and two more banana jacks that connect to an external load (see Section 3.3).

The three BNC connectors (J2, J4, and J5) are intended to provide input signals to the amplifier and to observe the output signal, respectively.

Connector J8 can be used to provide an external reference voltage, typically used to shift the amplifier output voltage when configured as differential amplifier in single-supply operation. Jumper JP5 is used to select between GND and the external reference voltage.

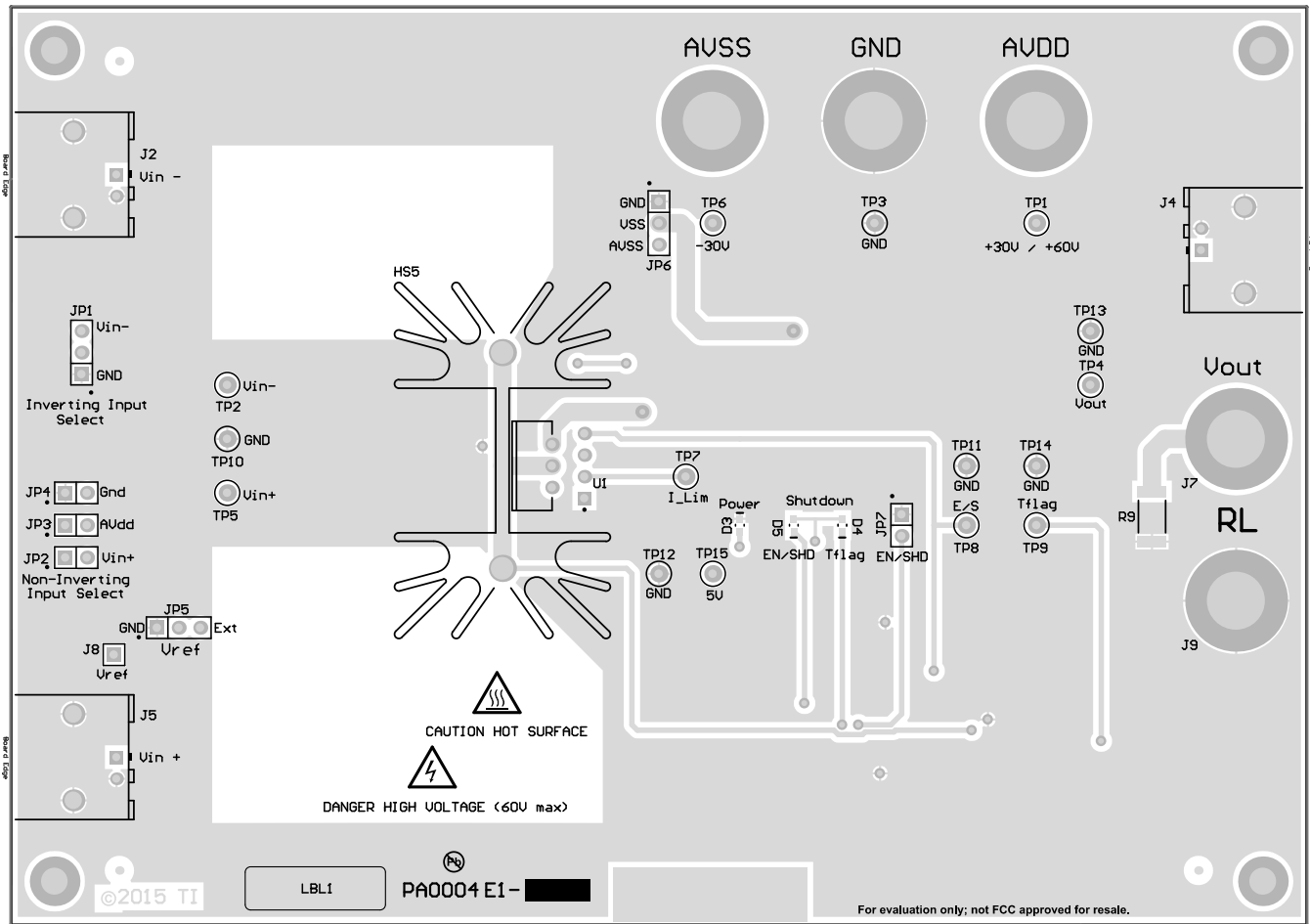
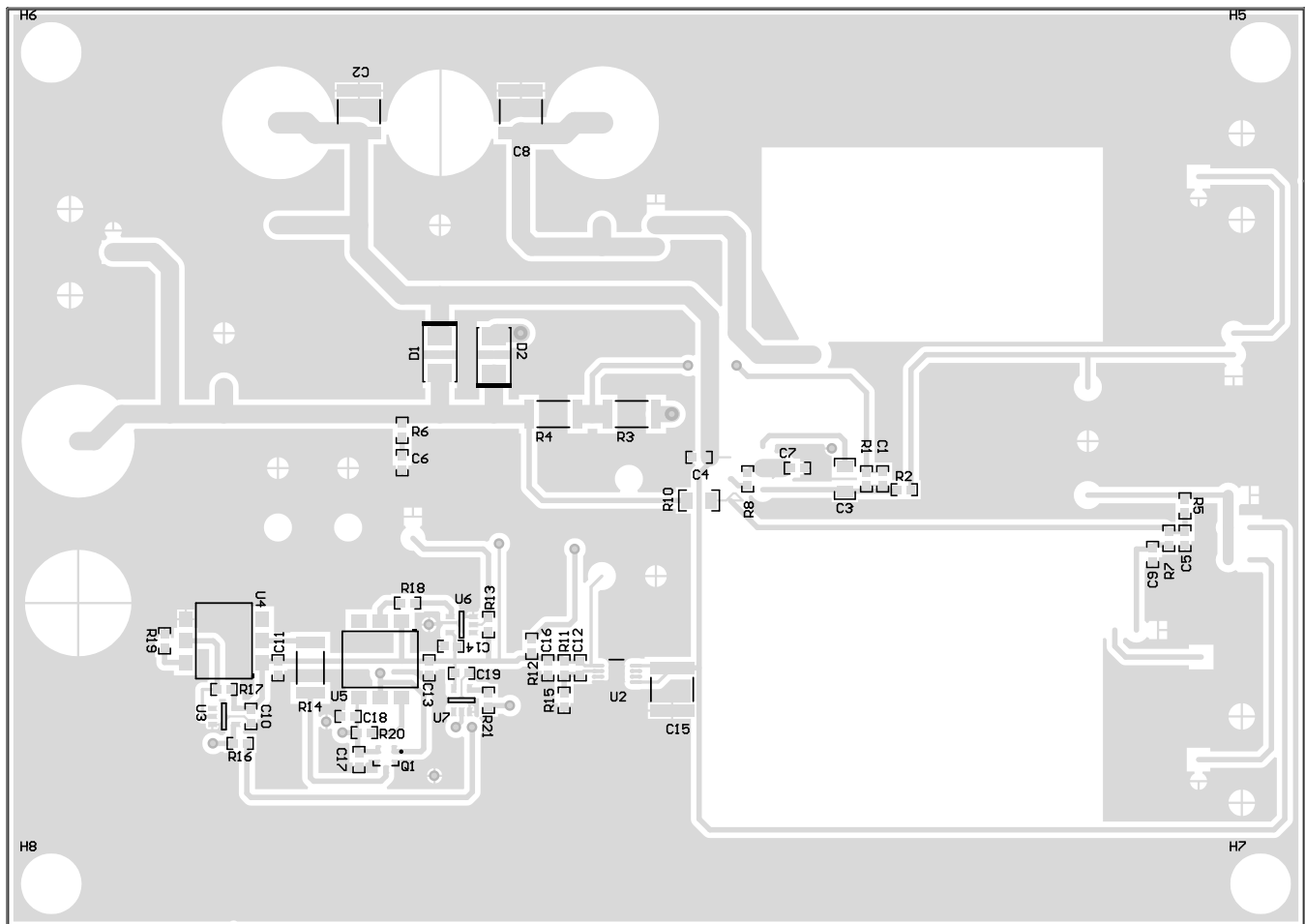

Figure 2. OPA547EVM, OPA548EVM Top Layer



**Figure 3. OPA547EVM, OPA548EVM Bottom Layer**

### 3 Getting Started

This chapter explains the purpose of the connectors and jumpers, how to configure the EVM, and how to make use of the features provided by the EVM.

#### 3.1 Power Supply

The OPA547EVM, OPA548EVM can be configured to use a single 8-V to 60-V supply (JP6, connecting VSS to GND) or a dual  $\pm 4$ -V to  $\pm 30$ -V supply (JP6, connecting VSS to AVSS). Power is provided to the EVM through three banana jacks AVDD (V+), GND, and AVSS (V-). The power supply must supply the total anticipated current required in the application. The OPA547 can supply a continuous dc current of 500 mA, while the OPA548 can deliver approximately 3 A of continuous dc current. TI recommends that the supply be capable of providing at least 2X the anticipated continuous current to account for peak current conditions. Make sure any cables used to carry high current are rated for such duty.



### 3.2 Inputs

The input to the EVM may be a dc source, an ac signal source (such as a signal generator), or any other signal within the common-mode voltage range. Note that 50- $\Omega$  termination resistors are not installed at the EVM inputs. Excessive power dissipation, under high input voltage conditions, can result in failure of the device. External, higher wattage BNC terminators can be added at the EVM input connectors if necessary.

The signal presented to the inverting OPA547, OPA548 input pin ( $V_{in-}$ ) is selected through JP1. JP1 can be set to select GND (JP1), or a signal applied at the BNC input connector J2.

The signal presented to the noninverting input ( $V_{in+}$ ) can be selected by JP2, JP3, or JP4. Selectable options are: GND, the positive power supply  $Av_{dd}$ , and a signal at the BNC connector J5.

### 3.3 Outputs

Output signals derived from the EVM may be monitored by whatever means required by the user. An oscilloscope provides a convenient way to observe the output waveform from the OPA547, OPA548. The output is brought to a BNC connector (J4) that is intended for the instrument connection, and to a pair of female banana jacks (J7, J9) intended to carry high output current. The load is intended to be located external to the EVM because of the variety of loads the OPA547, OPA548 can drive (which includes resistors, motors, transducers, and so forth), some of which may have to dissipate significant power, or be physically too large to reside on the EVM. If desired, a load resistor intended for low-power applications can be soldered on the PCB RL footprint.

### 3.4 Enable, Disable Feature

The EVM provides a means to test the enable, disable functionality of the OPA547 and OPA548. Placing a shunt across JP7 disables the amplifier output stage. Removing the shunt enables the amplifier, except when the amplifier is in thermal shutdown mode. LEDs indicate the current EVM status (see [Table 3](#)).

### 3.5 Current Limitation Capability

The OPA547EVM, OPA548EVM provide the means to limit the maximum output current that can be provided by the device. A resistor connected between the negative supply and the amplifier  $I_{lim}$  pin, or a voltage output digital-to-analog converter (DAC) connected to the  $I_{lim}$  pin, can be used to set the maximum output current limit. See the [OPA547](#) and [OPA548 data sheets](#) for detailed information.

By default, a 14.7-k $\Omega$  resistor ( $R_{cl}$ ) limits the output current to approximately 2.5 A for the OPA548 and approximately 510 mA for the OPA547. The user is free to set  $R_{cl}$  as desired. When using a DAC to set the current limitation,  $R_{cl}$  must be desoldered and the DAC output must be connected to the TP  $I_{lim}$  test point.

## 4 Noninverting Amplifier Configuration Setup

The EVM can be set to a noninverting configuration, as shown in Figure 4. This configuration can be operated in dual-supply mode or in single-supply mode.

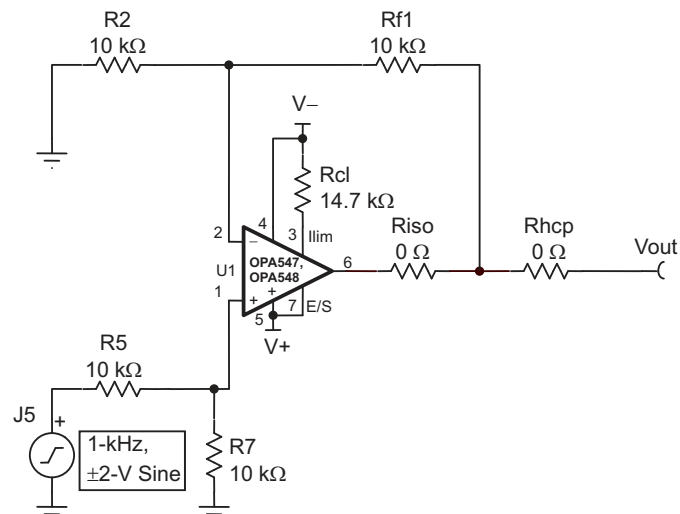

**Figure 4. Noninverting Amplifier Configuration Schematic**

Table 4 describes the noninverting amplifier PCB configuration.

**Table 4. Noninverting Configuration**

Reference	Setting	Function
Cf1, Cf2, C5	Not installed	—
JP1	Vin-	Routes Vin- across R3 to ground
JP2	Vin+	Routes Vin+ across R6 to the input signal (J6)
JP5	GND	Selects Vref (GND → no output voltage shift)
JP6	AVSS, GND	Selects AVSS (dual supply) or GND (single supply)
JP7	Open	Output is enabled
R7	10 kΩ	—
Rf+, RL	Not installed	—
Rhcp, Riso	0 Ω	—

Figure 5 shows the expected results for the noninverting operation of the OPA547 and OPA548. Figure 5a shows the noninverting operation in dual-supply mode and Figure 5b shows the noninverting operation in single-supply mode. The positive input of the op amp (IN+) is connected to the input signal of J6. The input signal is a sine wave with a peak amplitude of 2 V and a frequency of 1 kHz. The input signal for the single-supply configuration has an additional dc offset of 1.5 V.

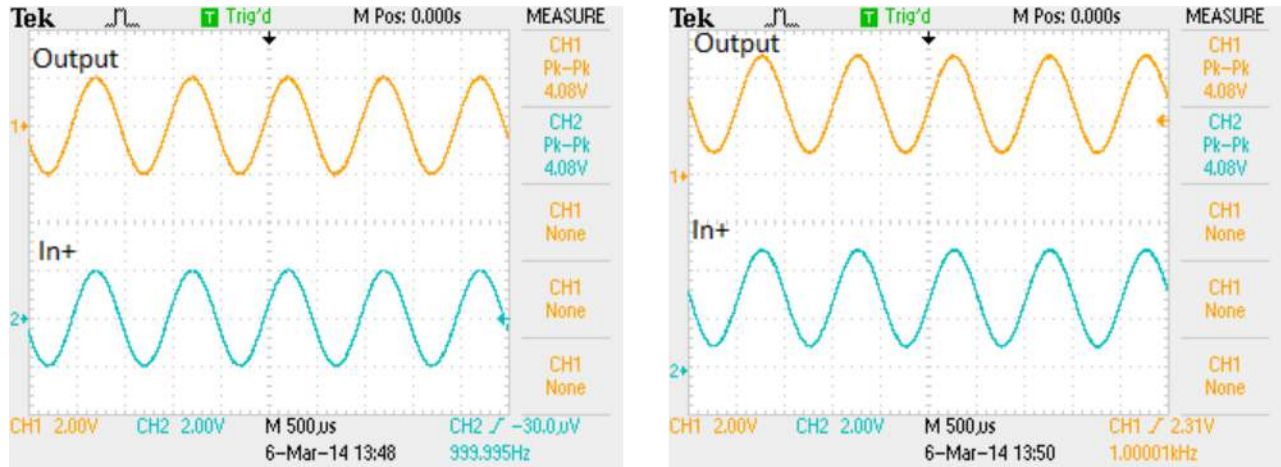

a) Dual-Supply Mode

b) Single-Supply Mode

Figure 5. Noninverting Operation

## 5 Inverting Amplifier Configuration Setup

The inverting operation configuration of the EVM is shown in [Figure 6](#). This configuration can be operated in dual-supply mode or in single-supply mode.

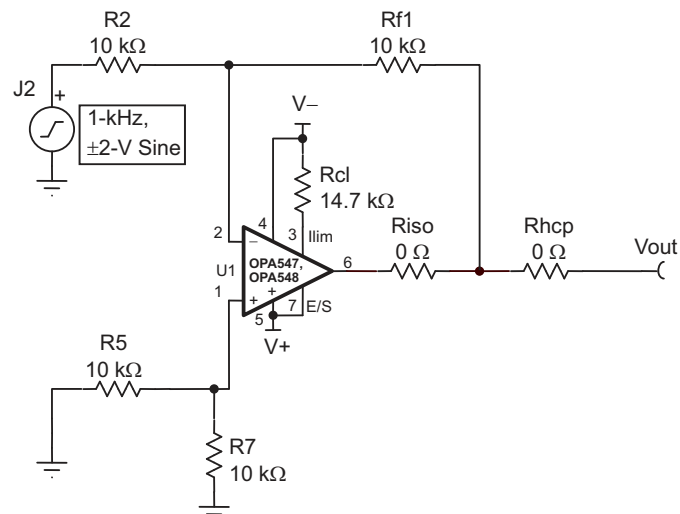

**Figure 6. Inverting Amplifier Configuration Schematic**

[Table 5](#) describes the inverting amplifier PCB configuration.

**Table 5. Inverting Configuration**

Reference	Setting	Function
Cf1, Cf2, C5	Not installed	—
JP1	Vin-	Routes Vin- across R3 to the input signal (J5)
JP4	Vin+	Routes Vin+ across R6 to ground
JP5	GND	Selects Vref (GND → no output voltage shift)
JP6	AVSS, GND	Selects AVSS (dual supply) or GND (single supply)
JP7	Open	Output is enabled
R7	10 kΩ	—
Rf+, RL	Not installed	—
Rhcp, Riso	0 Ω	—

Figure 7 shows the expected results for the inverting operation of the OPA547 and OPA548. Figure 7a shows the inverting operation in dual-supply mode and Figure 7b shows the inverting operation in single-supply mode. The negative input of the op amp (IN-) is connected to the input signal of J2. The input signal is a sine wave with a peak amplitude of 2 V and a frequency of 1 kHz. The input signal for the single-supply configuration has an additional dc offset of 1.5 V.

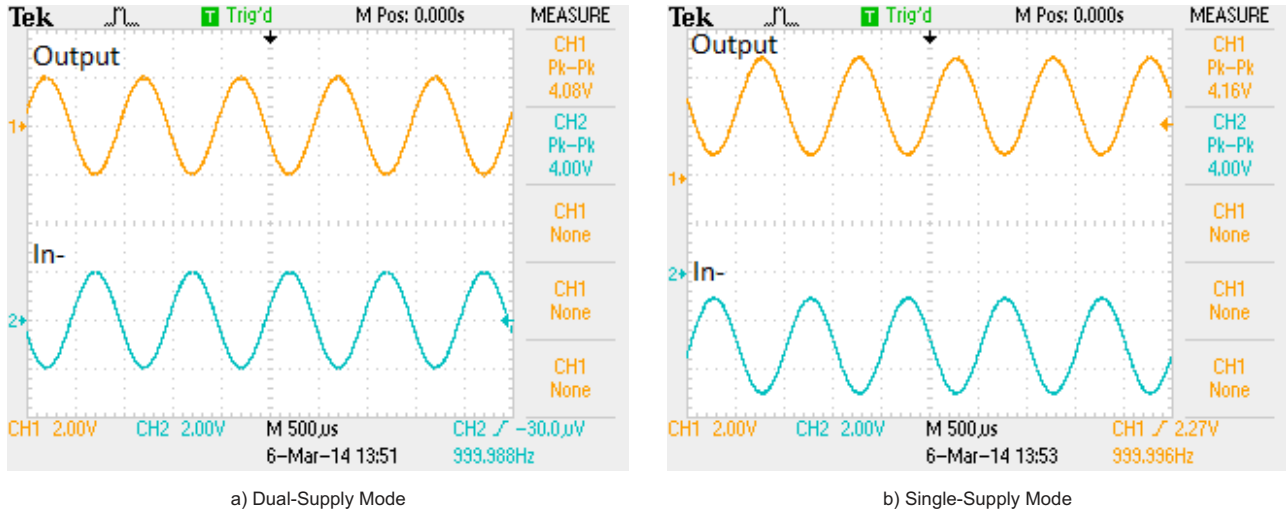
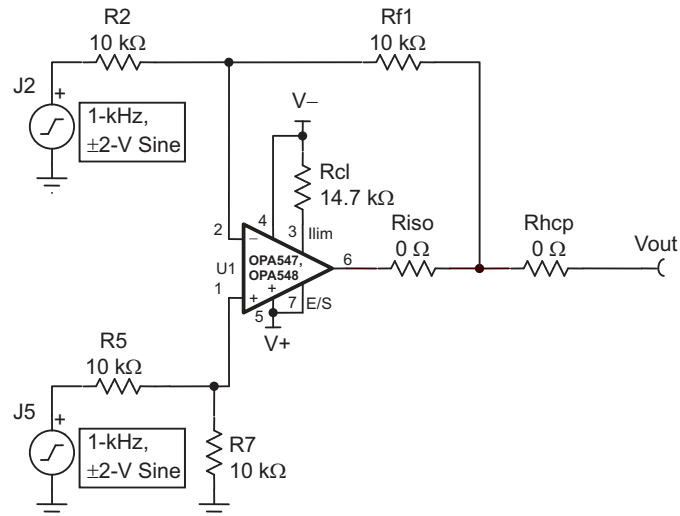

Figure 7. Inverting Operation

## 6 Differential Amplifier Configuration Setup

A further configuration of the EVM is the differential configuration, as shown in Figure 8. Both inputs are driven in this mode and the output is the difference between these inputs. This configuration can be operated in dual-supply mode or in single-supply mode.



**Figure 8. Differential Amplifier Configuration Schematic**

Table 6 describes the differential amplifier PCB configuration.

**Table 6. Differential Configuration**

Reference	Setting	Function
Cf1, Cf2, C5	Not installed	—
JP1	Vin-	Routes Vin- across R3 to the input signal (J5)
JP4	Vin+	Routes Vin+ across R6 to the input signal (J6)
JP5	GND	Selects Vref (GND → no output voltage shift; Vref → output voltage shifted by voltage provided to connector J10)
JP6	AVSS, GND	Selects AVSS (dual supply) or GND (single supply)
JP7	Open	Output is enabled
R7	10 kΩ	—
Rf+, RL	Not installed	—
Rhcp, Riso	0 Ω	—

Figure 9 shows the expected results for the differential operation of the OPA547 and OPA548. Figure 9a shows the differential operation in dual-supply mode and Figure 9b shows the differential operation in single-supply mode. The negative input of the op amp (IN-) is connected to the input signal of J2, while the positive input of the op amp (IN+) is connected to the input signal of J5. The input signals are rectangular waves with a peak amplitude of 2 V and a frequency of 1 kHz. The input signals for the single-supply configuration have an additional dc offset of  $\pm 1.5$  V. The positive input signal has a phase shift of 90 degrees relative to the negative input signal.

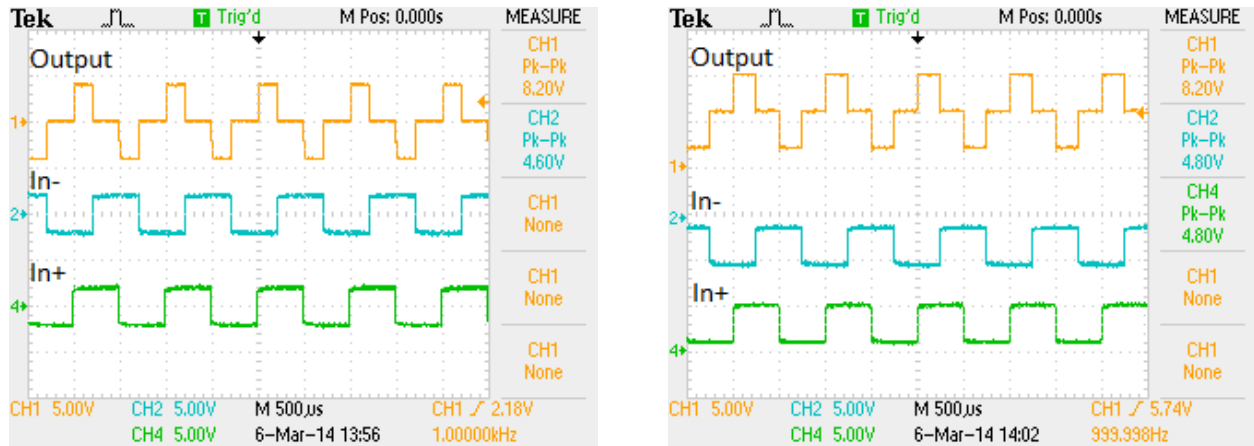

a) Dual-Supply Mode

b) Single-Supply Mode

Figure 9. Differential Operation

## 7 Improved Howland Current Pump Configuration Setup

The EVM can be configured as an improved Howland current pump, delivering precise currents to a load. Detailed information about the basic and improved Howland current pump can be found in application note AN-1515, *A Comprehensive Study of the Howland Current Pump*, [SNOA474](#). The OPA547EVM, OPA548EVM improved Howland current pump can be set up to drive a very low current in the microamp range up to the maximum output current of the device, as long as the amplifier is not driven beyond any of its limitations (such as output voltage, slew rate, and so forth).

The improved Howland current pump is applied by configuring the EVM according to the schematic shown in [Figure 10](#). [Table 7](#) shows the appropriate PCB configuration.

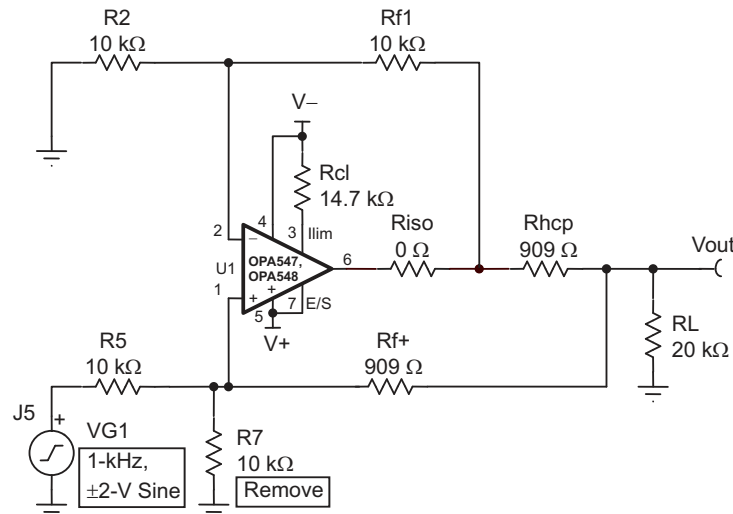

**Figure 10. Improved Howland Current Pump Schematic**

**Table 7. Improved Howland Current Pump Configuration**

Reference	Setting	Function
Cf1, Cf2, C5, C6	Not installed	—
JP1	Vin-	Routes Vin- across R3 to ground
JP4	Vin+	Routes Vin+ across R6 to the input signal (J6)
JP5	GND	Selects Vref (GND → no output voltage shift)
JP6	AVSS	Selects AVSS (dual supply)
JP7	Open	Output is enabled
R6, R7	Not installed	—
Rf+	9.09 kΩ	—
Rhcp	909 Ω	—
RL	20 kΩ	—

This PCB is designed to accommodate the additional components required for the Howland current pump configuration. The components that must be added or replaced are:

- R6, R7, C6, and Rhcp must be removed. Select values for Rf1, Rf+, and Rhcp using [Equation 1](#). R2 and R5 are both 10 kΩ by default. The 10-kΩ resistors can be replaced by resistors of other values if needed.
- Strictly adhere to the resistor relationship in [Equation 1](#):

$$\frac{Rf1}{R2} = \frac{(Rhcp + Rf+)}{R5} \quad (1)$$

R2 and R5 are 10 kΩ by default. If R2, R5, and Rf1 are all 10-kΩ resistor values, then the value of Rf+ added to the value of Rhcp must also be 10 kΩ.



- The output current range is mainly determined by Rhcp and is given by Equation 2:

$$I_{out} = \frac{(V_{in+}) - (V_{in-})}{R_{hcp}} \times \frac{R_{f1}}{R_2} \quad (2)$$

- $I_{out}$  flows through Rhcp. Ensure this resistor can handle the output current and can withstand the power that is dissipated.
- To lower the power dissipation in Rhcp, the ratio of Rf1 and R2 can be reduced (Rhcp can then be reduced by the same factor to obtain an equal output current). In this case, the value of R5 also must be changed to satisfy the resistor relationship in Equation 1. R2 and R5 are typically replaced with resistors of higher resistance to change these ratios.
- A differential input signal (JP1 to Vin- and shunt across JP2), or a single-ended voltage signal (JP1 to Vin- and shunt across JP4, or JP1 to Gnd and shunt across JP2) can be used to control the output current.

Using the settings and values listed in Table 7, the EVM is configured as a single-ended, noninverting amplifier with a ±30-V power supply. Rhcp is chosen as 909 Ω and Rf+ as 9.09 kΩ. Their sum is approximately 10 kΩ. A 20-kΩ resistor is selected for the load. The output current is calculated at ±825 μA for a ±750-mV input signal. The expected output is a ±16.5-V (33 V<sub>pp</sub>), 1-kHz sine, as shown in Figure 11. The measured result is slightly different from the expected result because the resistors are not trimmed and no high-precision resistors are used.

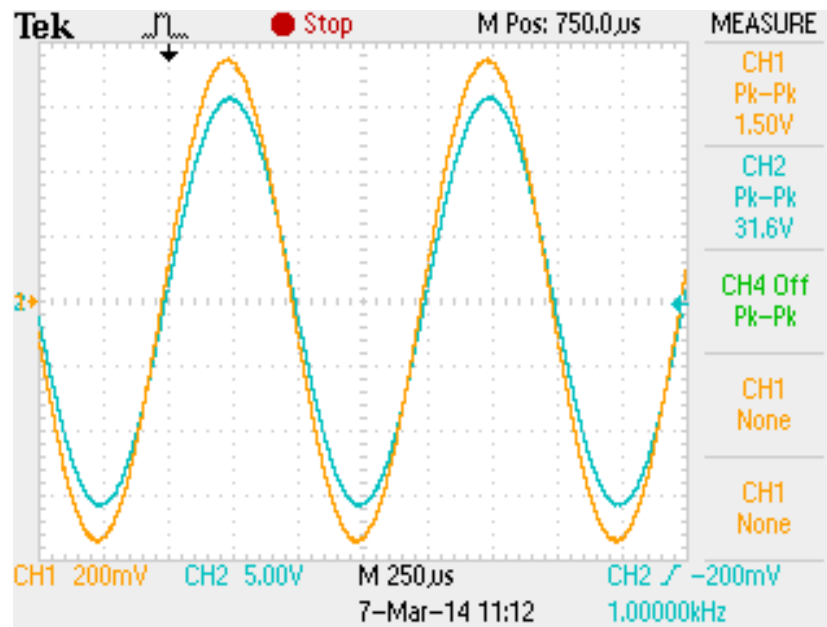

**Figure 11. Improved Howland Current Pump Operation**

In Figure 11, there are two traces. The yellow trace corresponds to input and the blue trace corresponds to output on a 20-kΩ resistor.

8 Appendix

Figure 12 shows the full schematic of the EVM.

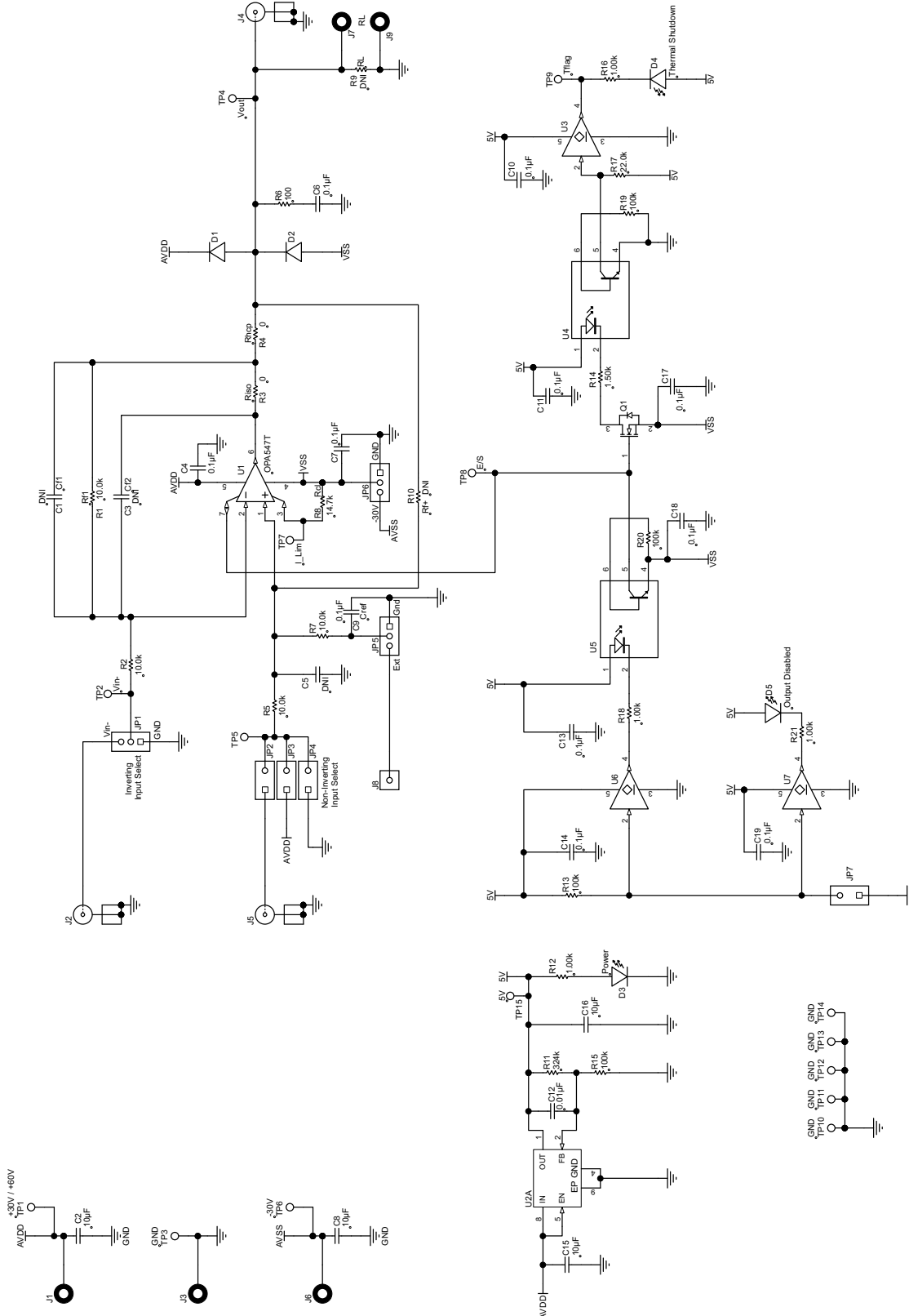

Figure 12. Complete OPA547EVM, OPA548EVM Schematics

## 8.1 Bill of Materials

**Table 8. Bill of Materials**

Quantity	Designator	Description	Manufacturer	Part Number	Supplier	Supplier Part Number
5	C1, C3, C5, R9, R10	Not Installed	—	—	—	—
3	C2, C8, C15	CAP, CERM, 10 µF, 100 V, +/- 20%, X7S, 2220	TDK	C5750X7S2A106M230KB	Digi-Key	445-5212-1-ND
11	C4, C6, C7, C9, C10, C11, C13, C14, C17, C18, C19	CAP, CERM, 0.1 µF, 100 V, +/- 10%, X7R, 0603	MuRata	GRM188R72A104KA35D	Digi-Key	490-3285-1-ND
1	C12	CAP, CERM, 0.01µF, 50V, +/-5%, X7R, 0603	Kemet	C0603C103J5RACTU	Digi-Key	399-1092-1-ND
1	C16	CAP, CERM, 10µF, 10V, +/-20%, X5R, 0603	TDK	C1608X5R1A106M	Digi-Key	445-6853-1-ND
2	D1, D2	Diode, Superfast Rectifier, 100 V, 3 A, SMB	Diodes Inc.	ES3BB-13-F	Digi-Key	ES3BB-FDIDKR-ND
1	D3	LED, Green, SMD	OSRAM	LG L29K-G2J1-24-Z	Digi-Key	475-2709-1-ND
1	D4	LED, Red, SMD	OSRAM	LS L29K-G1J2-1-Z	Digi-Key	475-2506-1-ND
1	D5	LED, Yellow, SMD	OSRAM	LY L29K-H1K2-26-Z	Digi-Key	475-1196-1-ND
5	H1, H2, H3, H4, HS1	MACHINE SCREW PAN PHILLIPS 4-40	B&F Fastener Supply	PMSS 440 0025 PH	Digi-Key	H703-ND
4	H5, H6, H7, H8	HEX STANDOFF 4-40 ALUMINUM 1/2"	Keystone	2203	Digi-Key	2203K-ND
1	HS2	Nut, Hex, 1/4" Thick, #4-40	B&F Fastener Supply	HNSS440	Digi-Key	H724-ND
1	HS3	Washer, Split Lock, #4	Keystone	4693	Digi-Key	4693K-ND
1	HS4	Washer, Flat, #4 Steel	TE Connectivity	5205820-3	Digi-Key	5205820-3-ND
1	HS5	Heat Sink, TO-220, Vertical	Aavid	530002B02500G	Digi-Key	HS380-ND
5	J1, J3, J6, J7, J9	Standard Banana Jack, Uninsulated, 15A	Emerson Network Power	108-0740-001	Digi-Key	J147-ND
3	J2, J4, J5	Jack, BNC, PCB, R/A, TH	TE Connectivity	1-1337543-0	Digi-Key	A97553-ND
1	J8	Header, TH, 100mil, 1pos, Gold plated, 230 mil above insulator	Sullins Connector Solutions	PBC01SAAN	Digi-Key	S1011E-01-ND
3	JP1, JP5, JP6	Header, 100mil, 3x1, Gold, TH	Samtec	TSW-103-07-G-S	Digi-Key	SAM1029-03-ND
4	JP2, JP3, JP4, JP7	Header, 100mil, 2x1, Gold, TH	Samtec	TSW-102-07-G-S	Digi-Key	SAM1029-02-ND
1	LBL1	Thermal Transfer Printable Labels, 0.650" W x 0.200" H - 10,000 per roll	Brady	THT-14-423-10	Farnell	2065596
1	Q1	MOSFET, N-CH, 60V, 0.24A, SOT-23	Vishay-Siliconics	SN7002E-T1-E3	Digi-Key	2N7002E-T1-E3-ND
4	R1, R2, R5, R7	RES, 10.0 k, 1%, 0.1 W, 0603	Vishay-Dale	CRCW060310K0FKEA	Digi-Key	541-10.0KHCT-ND
2	R3, R4	RES, 0, 5%, 1 W, 2512	Vishay-Dale	CRCW25120000Z0EG	Digi-Key	541-0.0XCT-ND
1	R6	RES, 100, 1%, 0.1 W, 0603	Vishay-Dale	CRCW0603100RFKEA	Digi-Key	541-100HCT-ND
1	R8	RES, 14.7 k, 1%, 0.1 W, 0603	Panasonic	ERJ-3EKF1472V	Digi-Key	P14.7KHCT-ND
1	R11	RES, 324 k, 1%, 0.1 W, 0603	Vishay-Dale	CRCW0603324KFKEA	Digi-Key	541-324KHCT-ND
4	R12, R16, R18, R21	RES, 1.00 k, 1%, 0.1 W, 0603	Vishay-Dale	CRCW06031K00FKEA	Digi-Key	541-1.00KHCT-ND
4	R13, R15, R19, R20	RES, 100 k, 1%, 0.1 W, 0603	Vishay-Dale	CRCW0603100KFKEA	Digi-Key	541-100KHCT-ND
1	R14	RES, 1.50 k, 1%, 1 W, 2512	Vishay-Dale	CRCW25121K50FKEG	Digi-Key	541-1.50KAFCT-ND
1	R17	RES, 22.0 k, 1%, 0.1 W, 0603	Panasonic	ERJ-3EKF2202V	Digi-Key	P22.0KHCT-ND
5	SH-JP1, SH-JP2, SH-JP3, SH-JP4, SH-JP5	Shunt, 100mil, Gold plated, Black	TE Connectivity	881545-2	Digi-Key	A26242-ND
2	TP1, TP15	Test Point, TH, Miniature, Red	Keystone	5000	Digi-Key	5000K-ND
6	TP2, TP4, TP5, TP7, TP8, TP9	Test Point, TH, Miniature, White	Keystone	5002	Digi-Key	5002K-ND
6	TP3, TP10, TP11, TP12, TP13, TP14	Test Point, TH, Miniature, Black	Keystone	5001	Digi-Key	5001K-ND

**Table 8. Bill of Materials (continued)**

Quantity	Designator	Description	Manufacturer	Part Number	Supplier	Supplier Part Number
1	TP6	Test Point, TH, Miniature, Yellow	Keystone	5004	Digi-Key	5004K-ND
1	U1	High-Voltage, High-Current Operational Amplifier, Excellent Output Swing, 8 to 60 V, -40 to 85 degC, 7-pin FM (KVT0007A)	Texas Instruments	OPA547T	Digi-Key	OPA547T-ND
1	U2	Single Output LDO, 50 mA, Adjustable 1.175 to 90 V Output, 7 to 100 V Input, 8-pin MSOP (DGN), -40 to 125 degC	Texas Instruments	TPS7A4001DGNR	Digi-Key	TPS7A4001DGNR-ND
1	U3	Single Inverter Gate, DBV0005A	Texas Instruments	SN74LVC1G04DBVR	—	—
2	U4, U5	High Voltage Phototransistor Optocoupler, MDIP_6L	Fairchild Semiconductor	4N38SR2M	Digi-Key	4N38SR2MCT-ND
2	U6, U7	SINGLE BUFFER/DRIVER WITH OPEN-DRAIN OUTPUT, DBV0005A	Texas Instruments	SN74LVC1G07DBVR	—	—

## STANDARD TERMS AND CONDITIONS FOR EVALUATION MODULES

1. *Delivery:* TI delivers TI evaluation boards, kits, or modules, including any accompanying demonstration software, components, or documentation (collectively, an "EVM" or "EVMs") to the User ("User") in accordance with the terms and conditions set forth herein. Acceptance of the EVM is expressly subject to the following terms and conditions.
  - 1.1 EVMs are intended solely for product or software developers for use in a research and development setting to facilitate feasibility evaluation, experimentation, or scientific analysis of TI semiconductors products. EVMs have no direct function and are not finished products. EVMs shall not be directly or indirectly assembled as a part or subassembly in any finished product. For clarification, any software or software tools provided with the EVM ("Software") shall not be subject to the terms and conditions set forth herein but rather shall be subject to the applicable terms and conditions that accompany such Software
  - 1.2 EVMs are not intended for consumer or household use. EVMs may not be sold, sublicensed, leased, rented, loaned, assigned, or otherwise distributed for commercial purposes by Users, in whole or in part, or used in any finished product or production system.
2. *Limited Warranty and Related Remedies/Disclaimers:*
  - 2.1 These terms and conditions do not apply to Software. The warranty, if any, for Software is covered in the applicable Software License Agreement.
  - 2.2 TI warrants that the TI EVM will conform to TI's published specifications for ninety (90) days after the date TI delivers such EVM to User. Notwithstanding the foregoing, TI shall not be liable for any defects that are caused by neglect, misuse or mistreatment by an entity other than TI, including improper installation or testing, or for any EVMs that have been altered or modified in any way by an entity other than TI. Moreover, TI shall not be liable for any defects that result from User's design, specifications or instructions for such EVMs. Testing and other quality control techniques are used to the extent TI deems necessary or as mandated by government requirements. TI does not test all parameters of each EVM.
  - 2.3 If any EVM fails to conform to the warranty set forth above, TI's sole liability shall be at its option to repair or replace such EVM, or credit User's account for such EVM. TI's liability under this warranty shall be limited to EVMs that are returned during the warranty period to the address designated by TI and that are determined by TI not to conform to such warranty. If TI elects to repair or replace such EVM, TI shall have a reasonable time to repair such EVM or provide replacements. Repaired EVMs shall be warranted for the remainder of the original warranty period. Replaced EVMs shall be warranted for a new full ninety (90) day warranty period.
3. *Regulatory Notices:*
  - 3.1 *United States*
    - 3.1.1 *Notice applicable to EVMs not FCC-Approved:*

This kit is designed to allow product developers to evaluate electronic components, circuitry, or software associated with the kit to determine whether to incorporate such items in a finished product and software developers to write software applications for use with the end product. This kit is not a finished product and when assembled may not be resold or otherwise marketed unless all required FCC equipment authorizations are first obtained. Operation is subject to the condition that this product not cause harmful interference to licensed radio stations and that this product accept harmful interference. Unless the assembled kit is designed to operate under part 15, part 18 or part 95 of this chapter, the operator of the kit must operate under the authority of an FCC license holder or must secure an experimental authorization under part 5 of this chapter.
    - 3.1.2 *For EVMs annotated as FCC – FEDERAL COMMUNICATIONS COMMISSION Part 15 Compliant:*

### CAUTION

This device complies with part 15 of the FCC Rules. Operation is subject to the following two conditions: (1) This device may not cause harmful interference, and (2) this device must accept any interference received, including interference that may cause undesired operation.

Changes or modifications not expressly approved by the party responsible for compliance could void the user's authority to operate the equipment.

### FCC Interference Statement for Class A EVM devices

*NOTE: This equipment has been tested and found to comply with the limits for a Class A digital device, pursuant to part 15 of the FCC Rules. These limits are designed to provide reasonable protection against harmful interference when the equipment is operated in a commercial environment. This equipment generates, uses, and can radiate radio frequency energy and, if not installed and used in accordance with the instruction manual, may cause harmful interference to radio communications. Operation of this equipment in a residential area is likely to cause harmful interference in which case the user will be required to correct the interference at his own expense.*

## FCC Interference Statement for Class B EVM devices

*NOTE: This equipment has been tested and found to comply with the limits for a Class B digital device, pursuant to part 15 of the FCC Rules. These limits are designed to provide reasonable protection against harmful interference in a residential installation. This equipment generates, uses and can radiate radio frequency energy and, if not installed and used in accordance with the instructions, may cause harmful interference to radio communications. However, there is no guarantee that interference will not occur in a particular installation. If this equipment does cause harmful interference to radio or television reception, which can be determined by turning the equipment off and on, the user is encouraged to try to correct the interference by one or more of the following measures:*

- Reorient or relocate the receiving antenna.
- Increase the separation between the equipment and receiver.
- Connect the equipment into an outlet on a circuit different from that to which the receiver is connected.
- Consult the dealer or an experienced radio/TV technician for help.

### 3.2 Canada

3.2.1 For EVMs issued with an Industry Canada Certificate of Conformance to RSS-210

#### Concerning EVMs Including Radio Transmitters:

This device complies with Industry Canada license-exempt RSS standard(s). Operation is subject to the following two conditions: (1) this device may not cause interference, and (2) this device must accept any interference, including interference that may cause undesired operation of the device.

#### Concernant les EVMs avec appareils radio:

Le présent appareil est conforme aux CNR d'Industrie Canada applicables aux appareils radio exempts de licence. L'exploitation est autorisée aux deux conditions suivantes: (1) l'appareil ne doit pas produire de brouillage, et (2) l'utilisateur de l'appareil doit accepter tout brouillage radioélectrique subi, même si le brouillage est susceptible d'en compromettre le fonctionnement.

#### Concerning EVMs Including Detachable Antennas:

Under Industry Canada regulations, this radio transmitter may only operate using an antenna of a type and maximum (or lesser) gain approved for the transmitter by Industry Canada. To reduce potential radio interference to other users, the antenna type and its gain should be so chosen that the equivalent isotropically radiated power (e.i.r.p.) is not more than that necessary for successful communication. This radio transmitter has been approved by Industry Canada to operate with the antenna types listed in the user guide with the maximum permissible gain and required antenna impedance for each antenna type indicated. Antenna types not included in this list, having a gain greater than the maximum gain indicated for that type, are strictly prohibited for use with this device.

#### Concernant les EVMs avec antennes détachables

Conformément à la réglementation d'Industrie Canada, le présent émetteur radio peut fonctionner avec une antenne d'un type et d'un gain maximal (ou inférieur) approuvé pour l'émetteur par Industrie Canada. Dans le but de réduire les risques de brouillage radioélectrique à l'intention des autres utilisateurs, il faut choisir le type d'antenne et son gain de sorte que la puissance isotrope rayonnée équivalente (p.i.r.e.) ne dépasse pas l'intensité nécessaire à l'établissement d'une communication satisfaisante. Le présent émetteur radio a été approuvé par Industrie Canada pour fonctionner avec les types d'antenne énumérés dans le manuel d'usage et ayant un gain admissible maximal et l'impédance requise pour chaque type d'antenne. Les types d'antenne non inclus dans cette liste, ou dont le gain est supérieur au gain maximal indiqué, sont strictement interdits pour l'exploitation de l'émetteur.

### 3.3 Japan

3.3.1 *Notice for EVMs delivered in Japan:* Please see [http://www.tij.co.jp/lstds/ti\\_ja/general/eStore/notice\\_01.page](http://www.tij.co.jp/lstds/ti_ja/general/eStore/notice_01.page) 日本国内に輸入される評価用キット、ボードについては、次のところをご覧ください。  
[http://www.tij.co.jp/lstds/ti\\_ja/general/eStore/notice\\_01.page](http://www.tij.co.jp/lstds/ti_ja/general/eStore/notice_01.page)

3.3.2 *Notice for Users of EVMs Considered "Radio Frequency Products" in Japan:* EVMs entering Japan may not be certified by TI as conforming to Technical Regulations of Radio Law of Japan.

If User uses EVMs in Japan, not certified to Technical Regulations of Radio Law of Japan, User is required by Radio Law of Japan to follow the instructions below with respect to EVMs:

1. Use EVMs in a shielded room or any other test facility as defined in the notification #173 issued by Ministry of Internal Affairs and Communications on March 28, 2006, based on Sub-section 1.1 of Article 6 of the Ministry's Rule for Enforcement of Radio Law of Japan,
2. Use EVMs only after User obtains the license of Test Radio Station as provided in Radio Law of Japan with respect to EVMs, or
3. Use of EVMs only after User obtains the Technical Regulations Conformity Certification as provided in Radio Law of Japan with respect to EVMs. Also, do not transfer EVMs, unless User gives the same notice above to the transferee. Please note that if User does not follow the instructions above, User will be subject to penalties of Radio Law of Japan.

【無線電波を送信する製品の開発キットをお使いになる際の注意事項】 開発キットの中には技術基準適合証明を受けていないものがあります。技術適合証明を受けていないもののご使用に際しては、電波法遵守のため、以下のいずれかの措置を取っていただく必要がありますのでご注意ください。

1. 電波法施行規則第6条第1項第1号に基づく平成18年3月28日総務省告示第173号で定められた電波暗室等の試験設備でご使用いただく。
2. 実験局の免許を取得後ご使用いただく。
3. 技術基準適合証明を取得後ご使用いただく。

なお、本製品は、上記の「ご使用にあたっての注意」を譲渡先、移転先に通知しない限り、譲渡、移転できないものとします。

上記を遵守頂けない場合は、電波法の罰則が適用される可能性があることをご留意ください。日本テキサス・インスツルメンツ株式会社  
東京都新宿区西新宿 6 丁目 2 4 番 1 号  
西新宿三井ビル

3.3.3 *Notice for EVMs for Power Line Communication:* Please see [http://www.tij.co.jp/llds/ti\\_ja/general/eStore/notice\\_02.page](http://www.tij.co.jp/llds/ti_ja/general/eStore/notice_02.page)  
電力線搬送波通信についての開発キットをお使いになる際の注意事項については、次のところをご覧ください。[http://www.tij.co.jp/llds/ti\\_ja/general/eStore/notice\\_02.page](http://www.tij.co.jp/llds/ti_ja/general/eStore/notice_02.page)

#### 4 *EVM Use Restrictions and Warnings:*

4.1 EVMS ARE NOT FOR USE IN FUNCTIONAL SAFETY AND/OR SAFETY CRITICAL EVALUATIONS, INCLUDING BUT NOT LIMITED TO EVALUATIONS OF LIFE SUPPORT APPLICATIONS.

4.2 User must read and apply the user guide and other available documentation provided by TI regarding the EVM prior to handling or using the EVM, including without limitation any warning or restriction notices. The notices contain important safety information related to, for example, temperatures and voltages.

#### 4.3 *Safety-Related Warnings and Restrictions:*

4.3.1 User shall operate the EVM within TI's recommended specifications and environmental considerations stated in the user guide, other available documentation provided by TI, and any other applicable requirements and employ reasonable and customary safeguards. Exceeding the specified performance ratings and specifications (including but not limited to input and output voltage, current, power, and environmental ranges) for the EVM may cause personal injury or death, or property damage. If there are questions concerning performance ratings and specifications, User should contact a TI field representative prior to connecting interface electronics including input power and intended loads. Any loads applied outside of the specified output range may also result in unintended and/or inaccurate operation and/or possible permanent damage to the EVM and/or interface electronics. Please consult the EVM user guide prior to connecting any load to the EVM output. If there is uncertainty as to the load specification, please contact a TI field representative. During normal operation, even with the inputs and outputs kept within the specified allowable ranges, some circuit components may have elevated case temperatures. These components include but are not limited to linear regulators, switching transistors, pass transistors, current sense resistors, and heat sinks, which can be identified using the information in the associated documentation. When working with the EVM, please be aware that the EVM may become very warm.

4.3.2 EVMs are intended solely for use by technically qualified, professional electronics experts who are familiar with the dangers and application risks associated with handling electrical mechanical components, systems, and subsystems. User assumes all responsibility and liability for proper and safe handling and use of the EVM by User or its employees, affiliates, contractors or designees. User assumes all responsibility and liability to ensure that any interfaces (electronic and/or mechanical) between the EVM and any human body are designed with suitable isolation and means to safely limit accessible leakage currents to minimize the risk of electrical shock hazard. User assumes all responsibility and liability for any improper or unsafe handling or use of the EVM by User or its employees, affiliates, contractors or designees.

4.4 User assumes all responsibility and liability to determine whether the EVM is subject to any applicable international, federal, state, or local laws and regulations related to User's handling and use of the EVM and, if applicable, User assumes all responsibility and liability for compliance in all respects with such laws and regulations. User assumes all responsibility and liability for proper disposal and recycling of the EVM consistent with all applicable international, federal, state, and local requirements.

5. *Accuracy of Information:* To the extent TI provides information on the availability and function of EVMs, TI attempts to be as accurate as possible. However, TI does not warrant the accuracy of EVM descriptions, EVM availability or other information on its websites as accurate, complete, reliable, current, or error-free.

6. *Disclaimers:*
- 6.1 EXCEPT AS SET FORTH ABOVE, EVMS AND ANY WRITTEN DESIGN MATERIALS PROVIDED WITH THE EVM (AND THE DESIGN OF THE EVM ITSELF) ARE PROVIDED "AS IS" AND "WITH ALL FAULTS." TI DISCLAIMS ALL OTHER WARRANTIES, EXPRESS OR IMPLIED, REGARDING SUCH ITEMS, INCLUDING BUT NOT LIMITED TO ANY IMPLIED WARRANTIES OF MERCHANTABILITY OR FITNESS FOR A PARTICULAR PURPOSE OR NON-INFRINGEMENT OF ANY THIRD PARTY PATENTS, COPYRIGHTS, TRADE SECRETS OR OTHER INTELLECTUAL PROPERTY RIGHTS.
- 6.2 EXCEPT FOR THE LIMITED RIGHT TO USE THE EVM SET FORTH HEREIN, NOTHING IN THESE TERMS AND CONDITIONS SHALL BE CONSTRUED AS GRANTING OR CONFERRING ANY RIGHTS BY LICENSE, PATENT, OR ANY OTHER INDUSTRIAL OR INTELLECTUAL PROPERTY RIGHT OF TI, ITS SUPPLIERS/LICENSORS OR ANY OTHER THIRD PARTY, TO USE THE EVM IN ANY FINISHED END-USER OR READY-TO-USE FINAL PRODUCT, OR FOR ANY INVENTION, DISCOVERY OR IMPROVEMENT MADE, CONCEIVED OR ACQUIRED PRIOR TO OR AFTER DELIVERY OF THE EVM.
7. *USER'S INDEMNITY OBLIGATIONS AND REPRESENTATIONS.* USER WILL DEFEND, INDEMNIFY AND HOLD TI, ITS LICENSORS AND THEIR REPRESENTATIVES HARMLESS FROM AND AGAINST ANY AND ALL CLAIMS, DAMAGES, LOSSES, EXPENSES, COSTS AND LIABILITIES (COLLECTIVELY, "CLAIMS") ARISING OUT OF OR IN CONNECTION WITH ANY HANDLING OR USE OF THE EVM THAT IS NOT IN ACCORDANCE WITH THESE TERMS AND CONDITIONS. THIS OBLIGATION SHALL APPLY WHETHER CLAIMS ARISE UNDER STATUTE, REGULATION, OR THE LAW OF TORT, CONTRACT OR ANY OTHER LEGAL THEORY, AND EVEN IF THE EVM FAILS TO PERFORM AS DESCRIBED OR EXPECTED.
8. *Limitations on Damages and Liability:*
- 8.1 *General Limitations.* IN NO EVENT SHALL TI BE LIABLE FOR ANY SPECIAL, COLLATERAL, INDIRECT, PUNITIVE, INCIDENTAL, CONSEQUENTIAL, OR EXEMPLARY DAMAGES IN CONNECTION WITH OR ARISING OUT OF THESE TERMS AND CONDITIONS OR THE USE OF THE EVMS PROVIDED HEREUNDER, REGARDLESS OF WHETHER TI HAS BEEN ADVISED OF THE POSSIBILITY OF SUCH DAMAGES. EXCLUDED DAMAGES INCLUDE, BUT ARE NOT LIMITED TO, COST OF REMOVAL OR REINSTALLATION, ANCILLARY COSTS TO THE PROCUREMENT OF SUBSTITUTE GOODS OR SERVICES, RETESTING, OUTSIDE COMPUTER TIME, LABOR COSTS, LOSS OF GOODWILL, LOSS OF PROFITS, LOSS OF SAVINGS, LOSS OF USE, LOSS OF DATA, OR BUSINESS INTERRUPTION. NO CLAIM, SUIT OR ACTION SHALL BE BROUGHT AGAINST TI MORE THAN ONE YEAR AFTER THE RELATED CAUSE OF ACTION HAS OCCURRED.
- 8.2 *Specific Limitations.* IN NO EVENT SHALL TI'S AGGREGATE LIABILITY FROM ANY WARRANTY OR OTHER OBLIGATION ARISING OUT OF OR IN CONNECTION WITH THESE TERMS AND CONDITIONS, OR ANY USE OF ANY TI EVM PROVIDED HEREUNDER, EXCEED THE TOTAL AMOUNT PAID TO TI FOR THE PARTICULAR UNITS SOLD UNDER THESE TERMS AND CONDITIONS WITH RESPECT TO WHICH LOSSES OR DAMAGES ARE CLAIMED. THE EXISTENCE OF MORE THAN ONE CLAIM AGAINST THE PARTICULAR UNITS SOLD TO USER UNDER THESE TERMS AND CONDITIONS SHALL NOT ENLARGE OR EXTEND THIS LIMIT.
9. *Return Policy.* Except as otherwise provided, TI does not offer any refunds, returns, or exchanges. Furthermore, no return of EVM(s) will be accepted if the package has been opened and no return of the EVM(s) will be accepted if they are damaged or otherwise not in a resalable condition. If User feels it has been incorrectly charged for the EVM(s) it ordered or that delivery violates the applicable order, User should contact TI. All refunds will be made in full within thirty (30) working days from the return of the components(s), excluding any postage or packaging costs.
10. *Governing Law:* These terms and conditions shall be governed by and interpreted in accordance with the laws of the State of Texas, without reference to conflict-of-laws principles. User agrees that non-exclusive jurisdiction for any dispute arising out of or relating to these terms and conditions lies within courts located in the State of Texas and consents to venue in Dallas County, Texas. Notwithstanding the foregoing, any judgment may be enforced in any United States or foreign court, and TI may seek injunctive relief in any United States or foreign court.

Mailing Address: Texas Instruments, Post Office Box 655303, Dallas, Texas 75265  
Copyright © 2015, Texas Instruments Incorporated



## IMPORTANT NOTICE

Texas Instruments Incorporated and its subsidiaries (TI) reserve the right to make corrections, enhancements, improvements and other changes to its semiconductor products and services per JESD46, latest issue, and to discontinue any product or service per JESD48, latest issue. Buyers should obtain the latest relevant information before placing orders and should verify that such information is current and complete. All semiconductor products (also referred to herein as "components") are sold subject to TI's terms and conditions of sale supplied at the time of order acknowledgment.

TI warrants performance of its components to the specifications applicable at the time of sale, in accordance with the warranty in TI's terms and conditions of sale of semiconductor products. Testing and other quality control techniques are used to the extent TI deems necessary to support this warranty. Except where mandated by applicable law, testing of all parameters of each component is not necessarily performed.

TI assumes no liability for applications assistance or the design of Buyers' products. Buyers are responsible for their products and applications using TI components. To minimize the risks associated with Buyers' products and applications, Buyers should provide adequate design and operating safeguards.

TI does not warrant or represent that any license, either express or implied, is granted under any patent right, copyright, mask work right, or other intellectual property right relating to any combination, machine, or process in which TI components or services are used. Information published by TI regarding third-party products or services does not constitute a license to use such products or services or a warranty or endorsement thereof. Use of such information may require a license from a third party under the patents or other intellectual property of the third party, or a license from TI under the patents or other intellectual property of TI.

Reproduction of significant portions of TI information in TI data books or data sheets is permissible only if reproduction is without alteration and is accompanied by all associated warranties, conditions, limitations, and notices. TI is not responsible or liable for such altered documentation. Information of third parties may be subject to additional restrictions.

Resale of TI components or services with statements different from or beyond the parameters stated by TI for that component or service voids all express and any implied warranties for the associated TI component or service and is an unfair and deceptive business practice. TI is not responsible or liable for any such statements.

Buyer acknowledges and agrees that it is solely responsible for compliance with all legal, regulatory and safety-related requirements concerning its products, and any use of TI components in its applications, notwithstanding any applications-related information or support that may be provided by TI. Buyer represents and agrees that it has all the necessary expertise to create and implement safeguards which anticipate dangerous consequences of failures, monitor failures and their consequences, lessen the likelihood of failures that might cause harm and take appropriate remedial actions. Buyer will fully indemnify TI and its representatives against any damages arising out of the use of any TI components in safety-critical applications.

In some cases, TI components may be promoted specifically to facilitate safety-related applications. With such components, TI's goal is to help enable customers to design and create their own end-product solutions that meet applicable functional safety standards and requirements. Nonetheless, such components are subject to these terms.

No TI components are authorized for use in FDA Class III (or similar life-critical medical equipment) unless authorized officers of the parties have executed a special agreement specifically governing such use.

Only those TI components which TI has specifically designated as military grade or "enhanced plastic" are designed and intended for use in military/aerospace applications or environments. Buyer acknowledges and agrees that any military or aerospace use of TI components which have **not** been so designated is solely at the Buyer's risk, and that Buyer is solely responsible for compliance with all legal and regulatory requirements in connection with such use.

TI has specifically designated certain components as meeting ISO/TS16949 requirements, mainly for automotive use. In any case of use of non-designated products, TI will not be responsible for any failure to meet ISO/TS16949.

### Products

Audio	<a href="http://www.ti.com/audio">www.ti.com/audio</a>
Amplifiers	<a href="http://amplifier.ti.com">amplifier.ti.com</a>
Data Converters	<a href="http://dataconverter.ti.com">dataconverter.ti.com</a>
DLP® Products	<a href="http://www.dlp.com">www.dlp.com</a>
DSP	<a href="http://dsp.ti.com">dsp.ti.com</a>
Clocks and Timers	<a href="http://www.ti.com/clocks">www.ti.com/clocks</a>
Interface	<a href="http://interface.ti.com">interface.ti.com</a>
Logic	<a href="http://logic.ti.com">logic.ti.com</a>
Power Mgmt	<a href="http://power.ti.com">power.ti.com</a>
Microcontrollers	<a href="http://microcontroller.ti.com">microcontroller.ti.com</a>
RFID	<a href="http://www.ti-rfid.com">www.ti-rfid.com</a>
OMAP Applications Processors	<a href="http://www.ti.com/omap">www.ti.com/omap</a>
Wireless Connectivity	<a href="http://www.ti.com/wirelessconnectivity">www.ti.com/wirelessconnectivity</a>

### Applications

Automotive and Transportation	<a href="http://www.ti.com/automotive">www.ti.com/automotive</a>
Communications and Telecom	<a href="http://www.ti.com/communications">www.ti.com/communications</a>
Computers and Peripherals	<a href="http://www.ti.com/computers">www.ti.com/computers</a>
Consumer Electronics	<a href="http://www.ti.com/consumer-apps">www.ti.com/consumer-apps</a>
Energy and Lighting	<a href="http://www.ti.com/energy">www.ti.com/energy</a>
Industrial	<a href="http://www.ti.com/industrial">www.ti.com/industrial</a>
Medical	<a href="http://www.ti.com/medical">www.ti.com/medical</a>
Security	<a href="http://www.ti.com/security">www.ti.com/security</a>
Space, Avionics and Defense	<a href="http://www.ti.com/space-avionics-defense">www.ti.com/space-avionics-defense</a>
Video and Imaging	<a href="http://www.ti.com/video">www.ti.com/video</a>

### TI E2E Community

[e2e.ti.com](http://e2e.ti.com)