

SMT Air Coil Inductor

AIAC-0805C

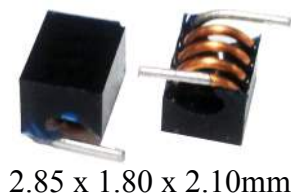

RoHS
Compliant



2.85 x 1.80 x 2.10mm

FEATURES:

- High current design
- Wide Range Frequency Response
- Excellent Q & SRF
- Standard flat cap top suitable for automatic placement.

APPLICATIONS:

- Widely used in Cordless Phones, High Frequency Communication Equipments, Intercom, CATV,RFID
- Suitable for metal sensors and proximity sensors
- Noise suppression for RF power supply/bias
- I/O filtering, frequency selection for audio devices such as Loudspeakers,Hifi
- Impedance Matching for transceivers
- Improves switch isolation for RF circuit

STANDARD SPECIFICATIONS:

PARAMETERS

ABRACON P/N:	AIAC-0805C
Operating temperature:	-40 °C ~ +125 °C
Storage temperature:	-25°C to + 60°C

Part Number	Inductance	Tolerance	DCR (Max)	Q(Min)	SRF(Min)	Rated Current (Max)	Inductance Code
Units	nH	%	mΩ		MHz	mA	
Symbol	L	K	DCR			IDC	
AIAC-0805C-3N9	3.9	K	2.6	80	>3000	1200	3N9
AIAC-0805C-4N7	4.7	K	3.6	80	>3000	900	4N7
AIAC-0805C-5N6	5.6	K	3.7	80	>3000	950	5N6
AIAC-0805C-6N8	6.8	K	4.5	80	>3000	900	6N8
AIAC-0805C-8N2	8.2	K	5.3	80	>3000	840	8N2
AIAC-0805C-10N	10	K	5.4	70	>3000	900	10N
AIAC-0805C-12N	12	K	6.3	70	>3000	900	12N
AIAC-0805C-15N	15	K	7.2	70	2500	900	15N
AIAC-0805C-18N	18	K	12.5	70	2500	500	18N
AIAC-0805C-22N	22	K	12.9	70	2400	550	22N
AIAC-0805C-27N	27	K	14.5	70	1600	550	27N
AIAC-0805C-33N	33	K	18.7	70	1600	500	33N

Test Conditions and equipments

Test frequency: 300MHz

Equipment: HP4286A/HP16191A

PART IDENTIFICATION:

AIAC-0805C- [] [] - []

Inductance Code

Please refer to the Electrical Spec Table

Tolerance

K: ±10%

Packaging

T: Tape and Reel
(4kpcs / reel)

SMT Air Coil Inductor

AIAC-0805C



RoHS
Compliant

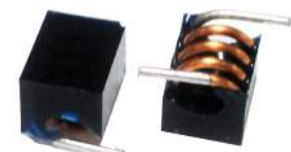

2.85 x 1.80 x 2.10mm

OUTLINE DRAWING:

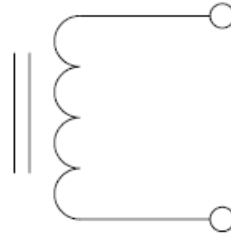
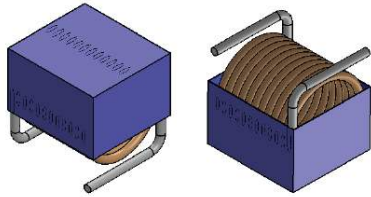
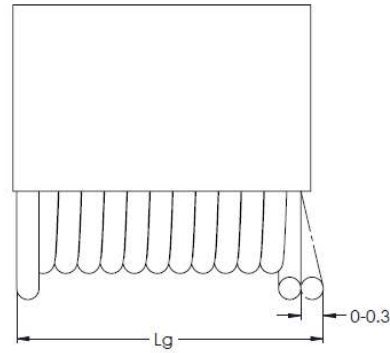
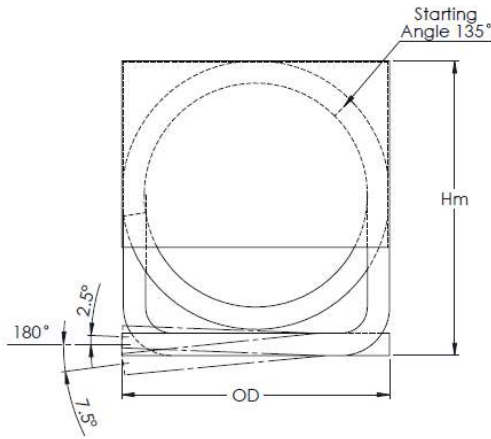

Hm	2.10 Max
OD	1.80 Max
Lg	2.85 Max

Recommended Land Pattern

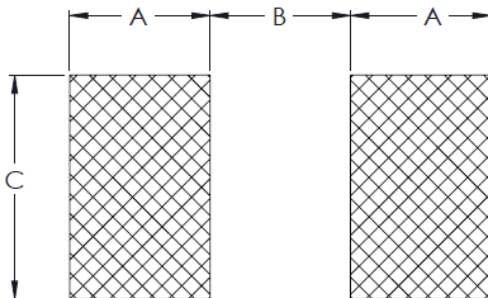

A	1.02 Min
B	0.76 Min
C	1.78 Min

Dimension: mm

SMT Air Coil Inductor

AIAC-0805C



RoHS
Compliant

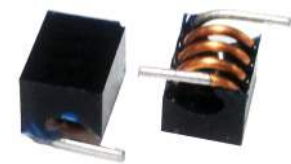

2.85 x 1.80 x 2.10mm

REFLOW PROFILE:

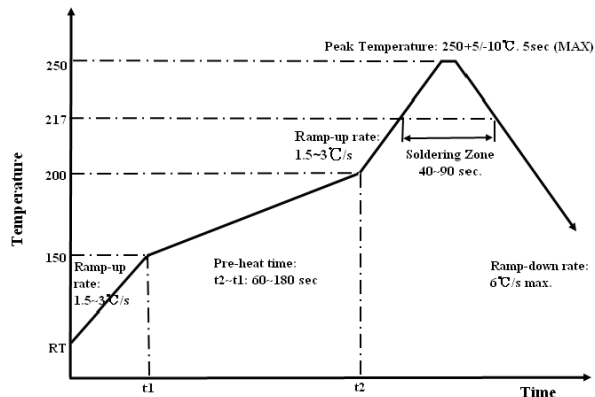

TAPE & REEL:

Packing

T: 4,000pcs / reel

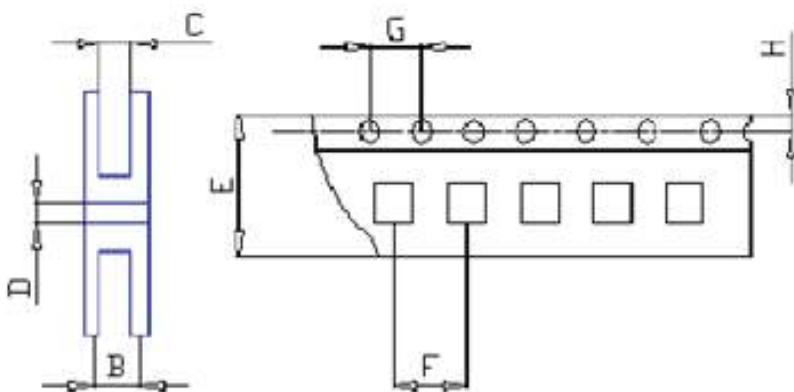

Ao	1.85±0.10
Bo	2.95±0.10
Ko	2.15±0.10
A	330
B	18
C	12
D	13
E	12
F	8.0
G	4.0
H	1.75
T	0.35

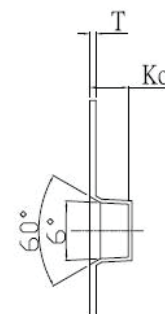

Dimension: mm

ATTENTION: Abracon LLC's products are COTS – Commercial-Off-The-Shelf products; suitable for Commercial, Industrial and, where designated, Automotive Applications. Abracon's products are not specifically designed for Military, Aviation, Aerospace, Life-dependent Medical applications or any application requiring high reliability where component failure could result in loss of life and/or property. For applications requiring high reliability and/or presenting an extreme operating environment, written consent and authorization from Abracon LLC is required. Please contact Abracon LLC for more information.