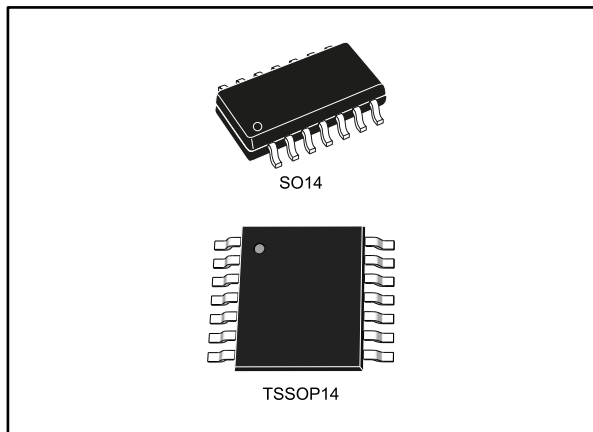

**Hex Schmitt inverter**

Datasheet - production data

**Description**

The M74HC14 is a high speed CMOS hex Schmitt inverter fabricated with silicon gate C<sup>2</sup>MOS technology. Pin configuration and functions are the same as those of the M74HC04 but all inputs have a 20 %  $V_{CC}$  hysteresis level.

This, together with the Schmitt trigger function, allows the device to be used on line receivers with slow rise/fall input signals.

All inputs are equipped with protection circuits against static discharge and transient excess voltage.

**Features**

- High speed:  $t_{PD} = 12$  ns (typ.) at  $V_{CC} = 6$  V
- Low power dissipation:  $I_{CC} = 1$   $\mu$ A (max.) at  $T_A = 25$  °C
- High noise immunity:  $V_H = 1.2$  V (typ.) at  $V_{CC} = 6$  V
- Symmetrical output impedance:  
 $|I_{OH}| = I_{OL} = 4$  mA (min.)
- Balanced propagation delays:  $t_{PLH} \approx t_{PHL}$
- Wide operating voltage range:  
 $V_{CC}(\text{opr}) = 2$  to 6 V
- Pin and function compatible with 74 series 14
- ESD performance
  - CDM: 1 kV
  - HBM: 2 kV
  - MM: 200 V

# Contents

- 1 Pin information ..... 3**
- 2 Functional description ..... 4**
- 3 Electrical characteristics ..... 5**
- 4 Package information ..... 8**
  - 4.1 SO14 package information..... 9
  - 4.2 SO14 tape and reel package information ..... 10
  - 4.3 TSSOP14 package information..... 11
  - 4.4 TSSOP14 tape and reel package information ..... 12
- 5 Ordering information..... 13**
- 6 Revision history ..... 14**



# 1 Pin information

Figure 1: Pin connections and IEC logic symbols

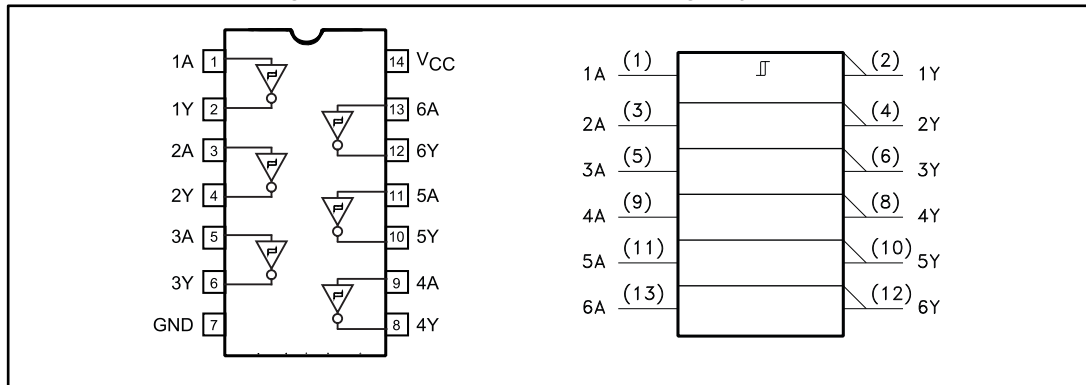

Table 1: Pin description

Pin number	Symbol	Name and function
1, 3, 5, 9, 11, 13	1A to 6A	Data inputs
2, 4, 6, 8, 10, 12	1Y to 6Y	Data outputs
7	GND	Ground (0 V)
14	V <sub>CC</sub>	Positive supply voltage

## 2 Functional description

Table 2: Truth table

A	Y
L	H
H	L

Figure 2: Input and output equivalent circuit

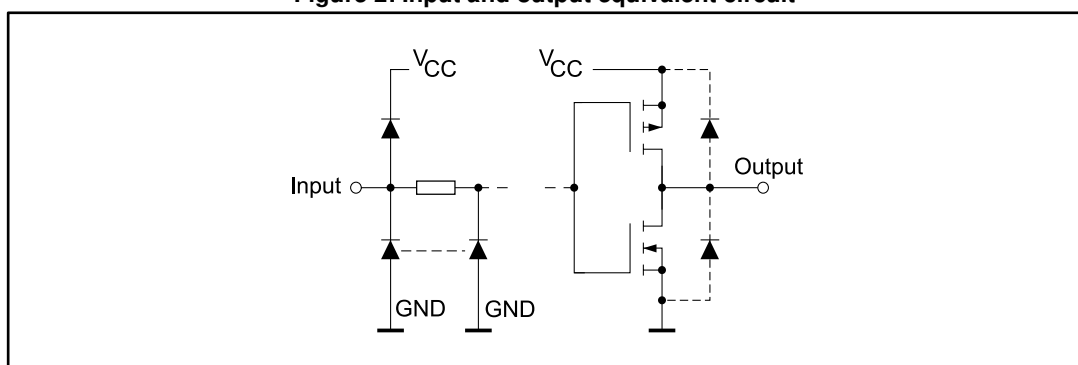

### 3 Electrical characteristics

Stressing the device above the ratings listed in the “Absolute maximum ratings” table may cause permanent damage to the device. These are stress ratings only, and operation of the device at these or any other conditions above those indicated in the operating sections of this specification are not implied. Exposure to absolute maximum rating conditions for extended periods may affect device reliability. Please refer to the STMicroelectronics SURE program and other relevant quality documents.

**Table 3: Absolute maximum ratings**

Symbol	Parameter	Value	Unit
$V_{CC}$	Supply voltage	-0.5 to 7	V
$V_I$	DC input voltage	-0.5 to $V_{CC} + 0.5$	
$V_O$	DC output voltage		
$I_{IK}$	DC input diode current	$\pm 20$	mA
$I_{OK}$	DC output diode current		
$I_O$	DC output current	$\pm 25$	
$I_{CC}$ or $I_{GND}$	DC $V_{CC}$ or ground current	$\pm 50$	
$P_D$	Power dissipation	500 <sup>(1)</sup>	mW
$T_{stg}$	Storage temperature	-65 to 150	°C
$T_L$	Lead temperature (10 s)	300	

**Notes:**

<sup>(1)</sup>500 mW at 65 °C; derate to 300 mW by 10 mW/°C from 65 °C to 85 °C

**Table 4: Recommended operating conditions**

Symbol	Parameter	Value	Unit
$V_{CC}$	Supply voltage	2 to 6	V
$V_I$	Input voltage	0 to $V_{CC}$	
$V_O$	Output voltage		
$T_{oper}$	Operating temperature	-55 to 125	°C

Table 5: DC specification

Sym	Parameter	Test condition		Value						Unit	
		V <sub>CC</sub> (V)		T <sub>A</sub> = 25 °C			-40 to 85 °C		-55 to 125 °C		
				Min	Typ	Max	Min	Max	Min		Max
V <sub>t+</sub>	High-level input voltage	2.0		1.0	1.28	1.5	1.0	1.5	1.0	1.5	V
		4.5		2.3	2.8	3.15	2.3	3.15	2.3	3.15	
		6.0		3.0	3.7	4.2	3.0	4.2	3.0	4.2	
V <sub>t-</sub>	Low-level input voltage	2.0		0.3	0.74	0.9	0.3	0.9	0.3	0.9	
		4.5		1.13	1.8	2.0	1.13	2.0	1.13	2.0	
		6.0		1.5	2.4	2.6	1.5	2.6	1.5	2.6	
V <sub>H</sub>	Hysteresis voltage	2.0		0.3	0.54	1.0	0.3	1.0	0.3	1.0	
		4.5		0.6	1.0	1.4	0.6	1.4	0.6	1.4	
		6.0		0.8	1.3	1.4	0.8	1.7	0.8	1.7	
V <sub>OH</sub>	High-level output voltage	2.0	I <sub>O</sub> = -20 μA	1.9	2.0		1.9		1.9		
		4.5		4.4	4.5		4.4		4.4		
		6.0		5.9	6.0		5.9		5.9		
		4.5	I <sub>O</sub> = -4.0 mA	4.18	4.31		4.13		4.10		
		6.0	I <sub>O</sub> = -5.2 mA	5.68	5.8		5.63		5.60		
V <sub>OL</sub>	Low-level output voltage	2.0	I <sub>O</sub> = -20 μA		0.0	0.1		0.1		0.1	
		4.5			0.0	0.1		0.1		0.1	
		6.0			0.0	0.1		0.1		0.1	
		4.5	I <sub>O</sub> = -4.0 mA		0.17	0.26		0.33		0.40	
		6.0	I <sub>O</sub> = -5.2 mA		0.18	0.26		0.33		0.40	
I <sub>I</sub>	Input leakage current	6.0	V <sub>I</sub> = V <sub>CC</sub> or GND			±0.1		±1		±1	μA
I <sub>CC</sub>	Quiescent supply current					1		10		20	

Table 6: AC electrical characteristics (CL = 50 pF, input tr = tf = 6 ns)

Sym.	Parameter	Test condition		Value			Value	
		V <sub>CC</sub> (V)		T <sub>A</sub> = 25 °C		-40 to 85 °C		-55 to 125 °C
				Typ	Max	Max		Max
t <sub>TLH</sub> , t <sub>THL</sub>	Output transition time	2.0		30	75	95	110	ns
		4.5		8	15	19	22	
		6.0		7	13	16	19	
t <sub>PLH</sub> , t <sub>PHL</sub>	Propagation delay time	2.0		42	125	155	190	
		4.5		14	25	31	38	
		6.0		12	21	16	32	

Table 7: Capacitive characteristics

Sym.	Parameter	Test condition		Value				Value
		V <sub>CC</sub> (V)		T <sub>A</sub> = 25 °C		-40 to 85 °C	-55 to 125 °C	
				Typ	Max	Max	Max	
C <sub>IN</sub>	Input capacitance	5.0		5	10	10	10	pF
C <sub>PD</sub>	Power dissipation capacitance <sup>(1)</sup>		f <sub>IN</sub> = 10 MHz	28				

**Notes:**

<sup>(1)</sup>CPD is defined as the value of the IC's internal equivalent capacitance which is calculated from the operating current consumption without load (refer to test circuit). Average operating current can be obtained by the following equation:  
 $ICC(opr) = CPD \times VCC \times f_{IN} + ICC/6(\text{per gate})$

Figure 3: Test circuit

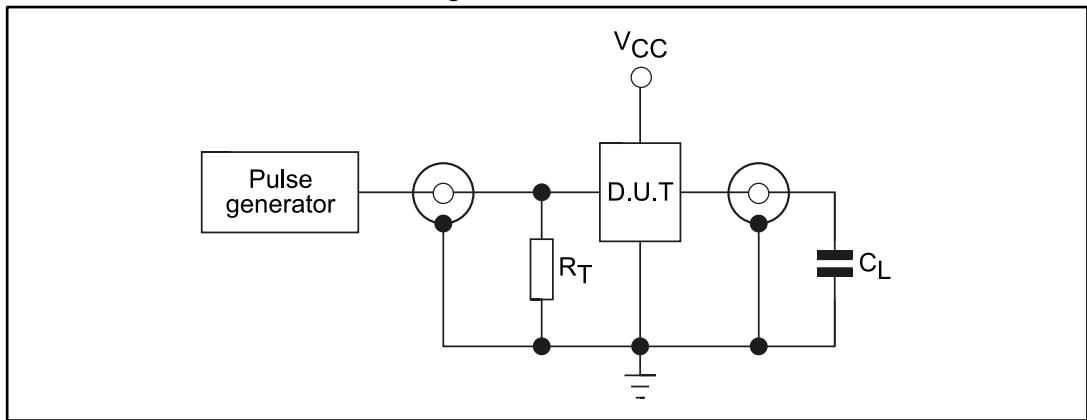
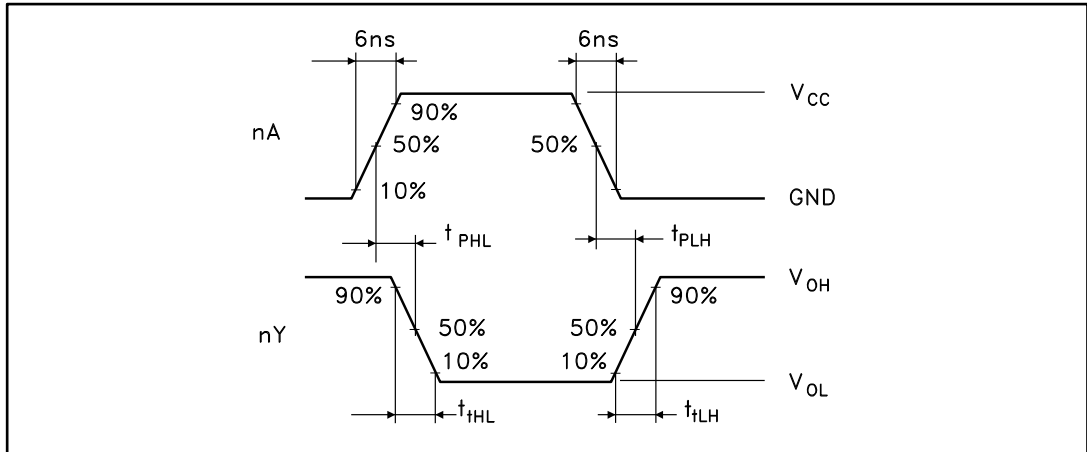

Figure 4: Waveform: propagation delay times (f = 1 MHz, 50 % duty cycle)



## 4 Package information

In order to meet environmental requirements, ST offers these devices in different grades of ECOPACK<sup>®</sup> packages, depending on their level of environmental compliance. ECOPACK<sup>®</sup> specifications, grade definitions and product status are available at: [www.st.com](http://www.st.com). ECOPACK<sup>®</sup> is an ST trademark.



### 4.1 SO14 package information

Figure 5: SO14 package outline

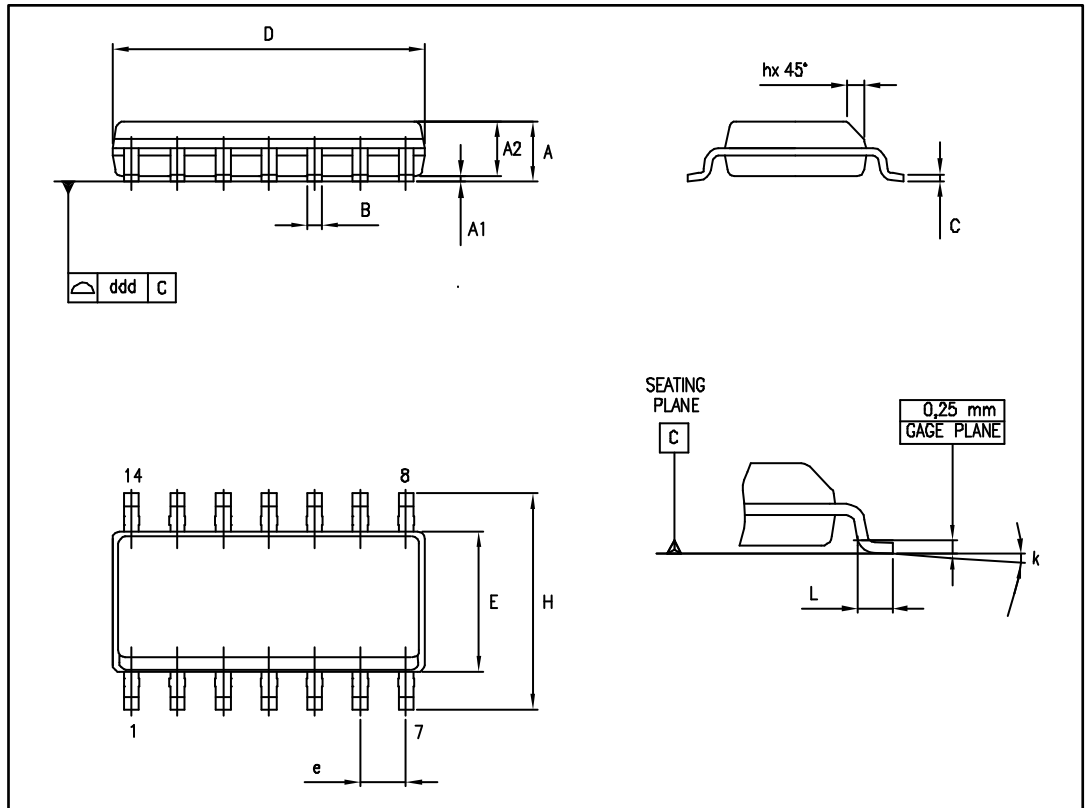
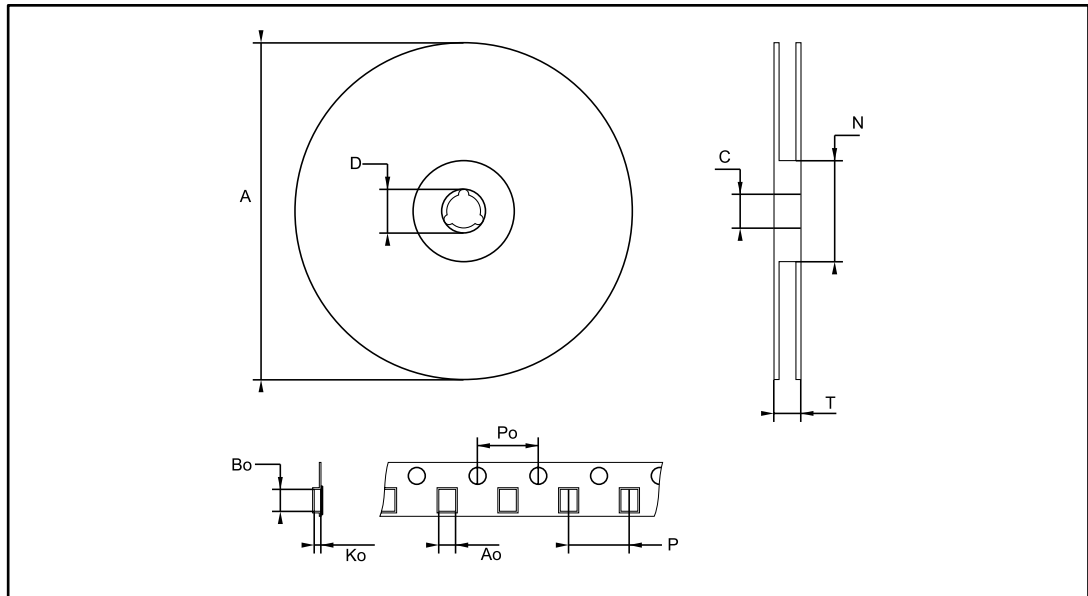

Table 8: SO14 mechanical data

Ref.	Dimensions					
	Millimeters			Inches		
	Min.	Typ.	Max.	Min.	Typ.	Max.
A	1.35		1.75	0.05		0.068
A1	0.10		0.25	0.004		0.009
A2	1.10		1.65	0.04		0.06
B	0.33		0.51	0.01		0.02
C	0.19		0.25	0.007		0.009
D	8.55		8.75	0.33		0.34
E	3.80		4.0	0.15		0.15
e		1.27			0.05	
H	5.80		6.20	0.22		0.24
h	0.25		0.50	0.009		0.02
L	0.40		1.27	0.015		0.05
k	8° (max)					
ddd			0.10			0.004

## 4.2 SO14 tape and reel package information

Figure 6: SO14 tape and reel package outline



1. Drawing is not to scale

Table 9: SO14 tape and reel mechanical data

Ref	Dimensions			
	Millimeters		Inches	
	Min.	Max.	Min.	Max.
A		330		12.992
C	12.8	13.2	0.504	0.519
D	20.2		0.795	
N	60		2.362	
T		22.4		0.882
Ao	6.4	6.6	0.252	0.260
Bo	9	9.2	0.354	0.362
Ko	2.1	2.3	0.082	0.090
Po	3.9	4.1	0.153	0.161
P	7.9	8.1	0.311	0.319

### 4.3 TSSOP14 package information

Figure 7: TSSOP14 package outline

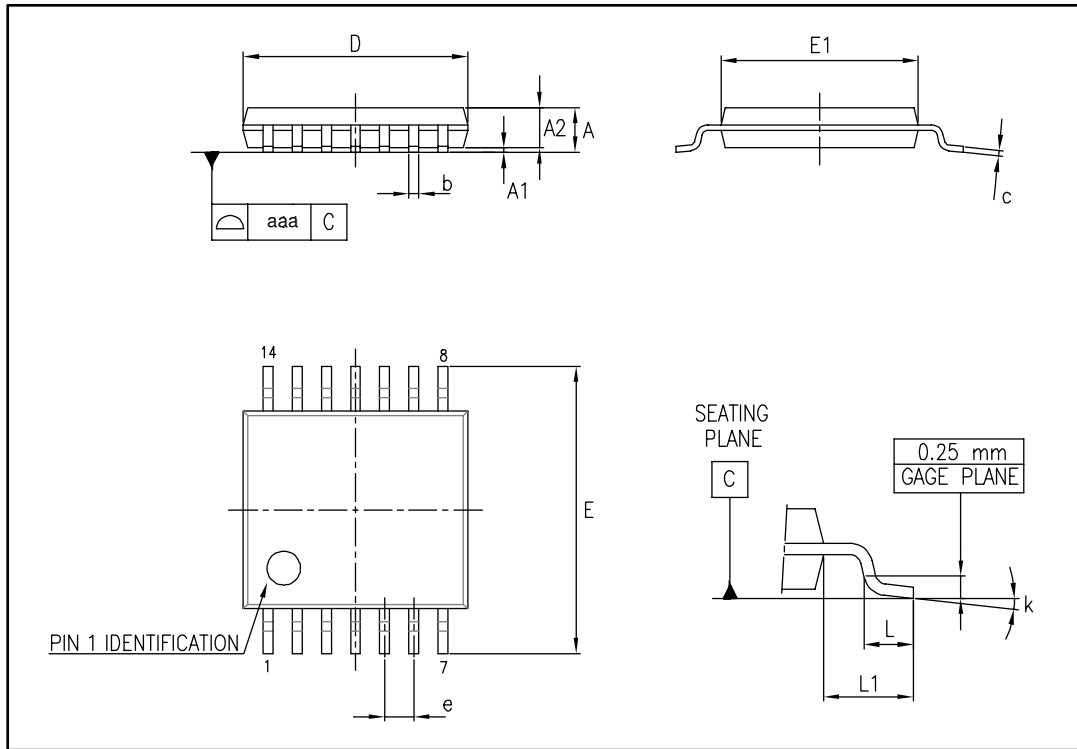
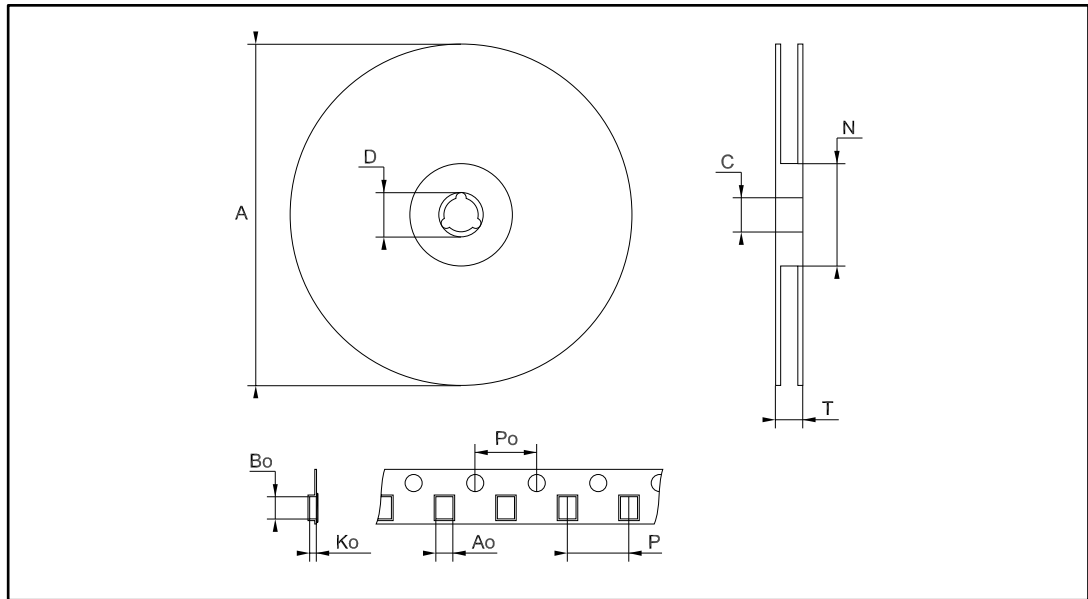

Table 10: TSSOP14 mechanical data

Ref.	Dimensions					
	Millimeters			Inches		
	Min.	Typ.	Max.	Min.	Typ.	Max.
A			1.20			0.047
A1	0.05		0.15	0.002	0.004	0.006
A2	0.80	1.00	1.05	0.031	0.039	0.041
b	0.19		0.30	0.007		0.012
c	0.09		0.20	0.004		0.0089
D	4.90	5.00	5.10	0.193	0.197	0.201
E	6.20	6.40	6.60	0.244	0.252	0.260
E1	4.30	4.40	4.50	0.169	0.173	0.176
e		0.65			0.0256	
L	0.45	0.60	0.75	0.018	0.024	0.030
L1		1.00			0.039	
k	0°		8°	0°		8°
aaa			0.10			0.004

### 4.4 TSSOP14 tape and reel package information

Figure 8: TSSOP14 tape and reel package outline



1. Drawing is not to scale

Table 11: TSSOP14 tape and reel mechanical data

Ref	Dimensions			
	Millimeters		Inches	
	Min.	Max.	Min.	Max.
A		330		12.992
C	12.8	13.2	0.504	0.519
D	20.2		0.795	
N	60		2.362	
T		22.4		0.882
Ao	6.7	6.9	0.264	0.272
Bo	5.3	5.5	0.209	0.217
Ko	1.6	1.8	0.063	0.071
Po	3.9	4.1	0.153	0.161
P	7.9	8.1	0.311	0.319

## 5 Ordering information

Table 12: Order codes

Order code	Temperature range	Package	Packing	Marking
M74HC14YRM13TR <sup>(1)</sup>	-40 °C to 125 °C	SO14 (automotive grade)	Tape and reel	74HC14Y
M74HC14YTTR <sup>(1)</sup>	-40 °C to 125 °C	TSSOP14 (automotive grade)		74HC14Y

**Notes:**

<sup>(1)</sup>Qualification and characterization according to AEC Q100 and Q003 or equivalent, advanced screening according to AEC Q001 and Q002.

## 6 Revision history

**Table 13: Document revision history**

Date	Revision	Changes
01-Jul-2001	1	Initial release.
23-May-2008	2	Document converted and restructured to new template. Removed: M74HC14M1R order code. Added: tape and reel specifications for SO-14 and TSSOP14 packages.
09-Aug-2013	3	Features: added ESD information Table 1: Device summary: added automotive grade order codes. Added Section 5: Ordering information.
13-Jan-2014	4	Removed DIP14 package Table 1: Device summary and Table 13: Order codes: added "Temperature range" and "Marking"; updated 1.
17-Feb-2016	5	Removed Table 1: Device summary (same table appears in <a href="#">Section 5: "Ordering information"</a> ). Replaced <a href="#">SO14 package information</a> <a href="#">TSSOP14 package information</a> : updated max E1 parameter (mm), added L1 and aaa parameters. Replaced <a href="#">TSSOP14 tape and reel package outline</a> <a href="#">Table 12: "Order codes"</a> : removed obsolete order codes M74HC14M13TR and M74HC14TTR; replaced the marking of order code M74HC14YTTR (74HC14Y instead of HC14Y).

**IMPORTANT NOTICE – PLEASE READ CAREFULLY**

STMicroelectronics NV and its subsidiaries ("ST") reserve the right to make changes, corrections, enhancements, modifications, and improvements to ST products and/or to this document at any time without notice. Purchasers should obtain the latest relevant information on ST products before placing orders. ST products are sold pursuant to ST's terms and conditions of sale in place at the time of order acknowledgement.

Purchasers are solely responsible for the choice, selection, and use of ST products and ST assumes no liability for application assistance or the design of Purchasers' products.

No license, express or implied, to any intellectual property right is granted by ST herein.

Resale of ST products with provisions different from the information set forth herein shall void any warranty granted by ST for such product.

ST and the ST logo are trademarks of ST. All other product or service names are the property of their respective owners.

Information in this document supersedes and replaces information previously supplied in any prior versions of this document.

© 2016 STMicroelectronics – All rights reserved