



TABLE OF CONTENTS

SECTION	PAGE
1.0 SCOPE.....	2
2.0 PRODUCT DESCRIPTION AND APPLICABLE DOCUMENTS .....	2
3.0 RATINGS.....	4
4.0 VISUAL EXAMINATION .....	5
5.0 ELECTRICAL PERFORMANCE .....	6
6.0 MECHANICAL PERFORMANCE .....	7
7.0 ENVIRONMENTAL PERFORMANCE .....	9
8.0 PACKAGING .....	10
9.0 TEST GROUPINGS.....	11
APPENDIX A .....	12
APPENDIX B.....	13
APPENDIX C .....	14
APPENDIX D .....	15
APPENDIX E.....	21
APPENDIX F .....	22
APPENDIX G .....	23
APPENDIX H: .....	24

REVISE ON PC ONLY:		TITLE:	<b>APPLIMATE 2.5MM CONNECTOR PRODUCT SPECIFICATION</b>			
<b>T</b>	ADDED SERIES # 93801  23/03/2016  TJ.Murphy					
THIS DOCUMENT CONTAINS INFORMATION THAT IS PROPRIETARY TO MOLEX			INC. AND SHOULD NOT BE USED WITHOUT WRITTEN PERMISSION			
REV.	DESCRIPTION	WRITTEN BY:	CHECKED BY:	APPROVED BY	DATE:	YR/MO/DAY
	DESIGN CONTROL <b>MXI</b>	STATUS RELEASED	B Maguire		2004/12/07	
DOCUMENT NUMBER PS-99020-0040					FILENAME PS990200040	SHEET 1 of 24
ES-40000-3996 REV. A SHEET 3 95/MAR/10 EC U5-0926 DCBRD03.LWP						



**1.0 SCOPE**

This specification defines the performance for the Molex RAST 2.5 APPLI-MATE family of connectors.

**2.0 PRODUCT DESCRIPTION AND APPLICABLE DOCUMENTS**

Series No	Description	Applicable Sales Drawing	Application Specification	Agency Approval	Mating Interface	Packaging Specification	
90871	2.5mm Appli-mate Female IDT Connector	SD-90871-001	AS-99033-0008	UL : E29179 CSA : LR 19980	Direct to PCB with optional 90873. Indirect through 93070 & 93072 or similar	PK-90871-001	
90872	2.5mm Appli-mate Female IDT Connector - Voided (5mm Pitch)	SD-90872-001					
91716	2.5mm Appli-mate Female IDT Connector (PA 6)	SD-91716-001					
91717	2.5Appli-mate Female IDT Connector (PA 6) Voided (5mm Pitch)	SD-91717-001					
93037 93366 93616	Appli-mate 2.5 Female with pips & slots	SD-93037-001 SD-93366-001 SD-93616-001					
93039 93367 93617	Appli-mate 2 Female with pips & slots (5mm pitch)	SD-93039-001 SD-93367-001 SD-93617-001					
93050 93334 93466 93801	Appli-mate 2.5 Female GWT version	PSD-93050-0001 SD-93334-001 PSD-93466-0001 SD-93801-001					
93051 93339 93385 93465 93802	Appli-mate 2.5 Female GWT version (5mm pitch)	PSD-93051-0001 SD-93339-001 PSD-93385-0001 PSD-93465-0001 SD-93802-001					
91780	2.5mm Appli-mate Female IDT connector with Side latch	SD-91780-001					Direct to PCB. See sales drawing
93070 93071	2.5mm Appli-mate Male vertical Header	SD-93070-001 SD-93071-001					N/A
93072 93073	2.5mm Appli-mate Male right angle header	SD-93072-001 SD-93073-001					
90873	2.5mm Appli-mate Male Guide Frame	SD-90873-001	N/A				

REVISE ON PC ONLY:		TITLE:	APPLIMATE 2.5MM CONNECTOR PRODUCT SPECIFICATION	
<b>S</b>	SEE SHEET 1			
THIS DOCUMENT CONTAINS INFORMATION THAT IS PROPRIETARY TO MOLEX INC. AND SHOULD NOT BE USED WITHOUT WRITTEN PERMISSION				
REV.	DESCRIPTION		FILENAME	SHEET
	DOCUMENT NUMBER PS-99020-0040		PS990200040	2 of 24



**Female Connector (Various Options Available)**

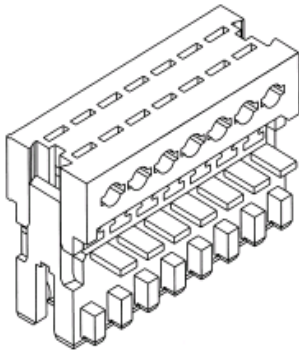

90871 90872  
 91716 91717  
 91780 93037  
 93039 93050  
 93051 93334  
 93339 93366  
 93367 93385  
 93466 93465  
 93616 93617  
 93801 93802

**Male Header (Vertical and Right Angle)**

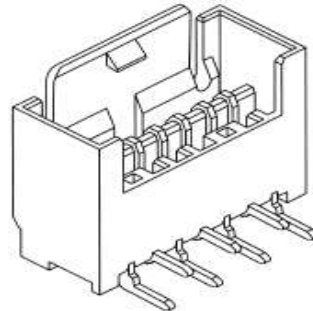
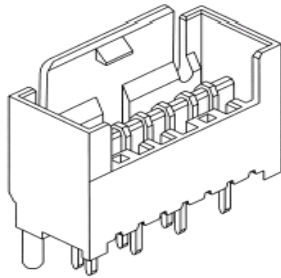

93070  
 93071  
 93072  
 93073

**Male Guide Frame (Optional)**

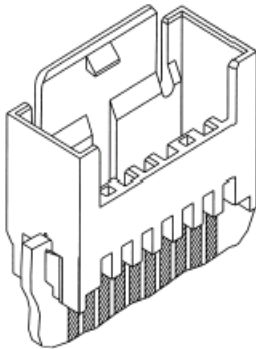

90873

REVISE ON PC ONLY:		TITLE:	APPLIMATE 2.5MM CONNECTOR PRODUCT SPECIFICATION	
<b>S</b>	SEE SHEET 1			
REV.	DESCRIPTION	THIS DOCUMENT CONTAINS INFORMATION THAT IS PROPRIETARY TO MOLEX INC. AND SHOULD NOT BE USED WITHOUT WRITTEN PERMISSION		
DOCUMENT NUMBER PS-99020-0040		FILENAME PS990200040	SHEET 3 of 24	



**3.0 RATINGS**

Item	Description	Rating	Applicable Series		
3.1	Current ( See derating curve Appendix D)	4 Amp	90871	93037	93339
		2 Amp	90872	93039	93366
			91716	93050	93367
			91717	93051	93385
			91780	93334	93466
93465	93616	93617			
93801	93802				
		6 Amp	93070	93072	
			93071	93073	
		N/A	90873		
3.2	Voltage	32V AC	90871	93037	93072
			91716	93050	93334
			91780	93070	93366
			93466	93616	93801
		250V AC	91717	93071	93465
93039	93385		93617		
93367	93073		93802		
		N/A	90873		
3.3	Durability	10 Cycles	90871	93051	93385
3.4	Operating Temperature Range (See derating curve Appendix D)	4 Amp: -20°C to 60°C With header	90872	93070	93465
		2 Amp: -20°C to +120°C double sided PCB or Header	90873	93071	93466
			91716	93072	93801
			91717	93073	93802
			91780	93617	
-20°C to +110°C Single Sided PCB	93037	93334			
	93616	93339			
	93039	93366			
3.5	Storage Temperature Range	-20°C to +85°C	93050	93367	
3.6	Material RTI UL 746b	125°C	91780		
		130°C	90871	93051	93339
			90872	93070	93366
			90873	93071	93367
			93037	93072	93385
93039	93073		93465		
93050	93334		93466		
93616	93617	93801			
93802					
		150°C	91716	91717	

REVISE ON PC ONLY:		TITLE:	APPLIMATE 2.5MM CONNECTOR PRODUCT SPECIFICATION	
<b>S</b>	SEE SHEET 1			
THIS DOCUMENT CONTAINS INFORMATION THAT IS PROPRIETARY TO MOLEX INC. AND SHOULD NOT BE USED WITHOUT WRITTEN PERMISSION				
REV.	DESCRIPTION		FILENAME	SHEET
	DOCUMENT NUMBER PS-99020-0040		PS990200040	4 of 24



4.0 VISUAL EXAMINATION

Item	Description	Test Condition	Requirements
4.1	Visual Examination (IEC 512-1-1)	Parts checked for: Identification, Workmanship Finish, Markings, Cosmetic issues, Tool marks.	Meets requirements of product drawing. All parts shall be free of hazardous substances. All parts to be free of dirt and grease. No Defects

REVISE ON PC ONLY:

S

SEE SHEET 1

TITLE:

APPLIMATE 2.5MM CONNECTOR  
PRODUCT SPECIFICATION

THIS DOCUMENT CONTAINS INFORMATION THAT IS PROPRIETARY TO MOLEX  
INC. AND SHOULD NOT BE USED WITHOUT WRITTEN PERMISSION

REV.

DESCRIPTION

DOCUMENT NUMBER  
PS-99020-0040

FILENAME  
PS990200040

SHEET  
5 of 24



**5.0 ELECTRICAL PERFORMANCE**

Item	Description	Test Condition	Requirements	Applicable Series		
5.1	Contact Resistance (IEC 60512-2-1)	Mated connector measured as per Appendix A: Low level contact resistance @20mV, 100mA max.	5mΩ maximum (double sided PCB). 10 mΩ max. (single sided PCB or Header*)	90871	93039	93071
				90872	93050	93072
				91716	93051	93073
				91717	91780	93339
				93037	93070	93334
5.2	Insulation resistance (IEC 60512-3-1) Method C	Unmated connector with 500VDC between adjacent contacts for 1 minute.	>1000 MΩ >5MΩ after salt spray 7.6	93366	93367	93385
				93465	93466	93616
				93617	93801	93802
5.3	Dielectric Withstand Voltage (IEC 60512-4-1) Method C	Unmated connector with rated Voltage eff./60sec	Rated Voltage = 1000V AC No Breakdown	90871	93037	93072
				91716	93050	93334
				91780	93070	93339
				93366	93385	93466
				93616	93801	
			Rated Voltage = 1500V AC No Breakdown	90872	93071	93051
				91717	93039	93073
				93367	93465	93617
				93802		
5.4	Current Induced Temperature Rise (IEC 512-2,5a)	Load all circuits with the rated current	A maximum temperature rise of ≤ 30°C	90871	93039	93071
				90872	93050	93072
				91716	93051	93073
				91717	91780	93339
5.5	Derating Curve (IEC 60512-2,5b)	See Appendix D	See Appendix D	93037	93070	93334
				93366	93367	93385
				93465	93466	93616
				93617	93801	93802
5.6	Contact Resistance 1Amp (IEC 60512-2-2)	Mated connector measured as per Appendix A: Test current 1Amp.	Contact resistance ≤12mΩ			

Note: Electrical Performance not applicable to series 90873

REVISE ON PC ONLY:		TITLE:	APPLIMATE 2.5MM CONNECTOR PRODUCT SPECIFICATION		
<b>S</b>	SEE SHEET 1				
THIS DOCUMENT CONTAINS INFORMATION THAT IS PROPRIETARY TO MOLEX INC. AND SHOULD NOT BE USED WITHOUT WRITTEN PERMISSION					
REV.	DESCRIPTION			FILENAME	SHEET
	DOCUMENT NUMBER PS-99020-0040			PS990200040	6 of 24



6.0 MECHANICAL PERFORMANCE

Item	Description	Test Condition	Requirements	Applicable Series
6.1	Mating Force (IEC 60512-13-1)	10 cycles. Force measured using a polished, steel pin as per appendix G	$\leq 4N$ per terminal for all 10 cycles	90871 91717 93339 90872 93051 93050 91716 93334 93385 93466 93616 93801 93802
			$\leq 10N + 4N$ per terminal for all 10 cycles (using Standard FR4 PCB)	93037 93366 93039 93367 93465 93617
			$\leq 15N + 4N$ per terminal for all 10 cycles	91780
			N/A	93070 93072 93071 93073
6.2	Unmating Force (IEC 60512-13-1)	10 cycles. Force measured using a polished, steel pin as per appendix G	$\geq 0.5N$ per terminal for all 10 cycles	90871 93339 93334 90872 91716 93050 93051 91717 93385 93466 93465 93801 93802
			1st Withdrawal $\geq 7N + 0.5N$ per terminal, 10th Withdrawal $\geq 5N + 0.5N$ per terminal	93037 93616 93039 93617 93366 93367
			1st Withdrawal $\geq 10N + 0.5N$ per terminal 10th Withdrawal $\geq 5N + 0.5N$ per terminal (See appendix E)	91780
			N/A	93070 93072 93071 93073
6.3	IDT Wire Retention Force	Apply a straight tensile force parallel and at 90° to the direction of the wire at a rate of 25-100mm per minute. Setup as per appendix H	<u>Parallel to wire</u> $\geq 30N$ <u>90° to the wire</u> $\geq 30N$	90871 93039 93339 90872 93050 93366 91716 93385 93465 91717 93616 93466 93367 93617 93801 91780 93051 93802 93037 93334
			N/A	93070 93072 93071 93073

REVISE ON PC ONLY:		TITLE:	APPLIMATE 2.5MM CONNECTOR PRODUCT SPECIFICATION	
S	SEE SHEET 1			
THIS DOCUMENT CONTAINS INFORMATION THAT IS PROPRIETARY TO MOLEX INC. AND SHOULD NOT BE USED WITHOUT WRITTEN PERMISSION				
REV.	DESCRIPTION			
DOCUMENT NUMBER PS-99020-0040		FILENAME PS990200040	SHEET 7 of 24	



PRODUCT SPECIFICATION



LANGUAGE

English

6.4	Vibration (IEC 60068-2-6,Fc)	Frequency cycle: 5-500-5Hz Displacement: 7.5mm Acceleration : 2g 20 min sweep 3hrs per axis	Initial contact resistance as per 5.1. Final contact resistance $\leq$ twice the initial contact resistance. No discontinuities greater than 1.0 microsecond.	90871 90872 91716 91717 93037 93366 93039 93050	93051 91780 93070 93367 93616 93617 93071 93072	93073 93334 93339 93385 93465 93466 93801 93802
6.5	Vibration	Connectors to be terminated with 0.35sq mm wire L=300mm and mated to PCB. Ends of wire to be secured at 210mm from the connector. Test current = 100+/- 10mA. Current interruptions no longer than 1 $\mu$ sec. Test on three axes 8 hrs each. The vibration frequency shall be continuously varied at 1 Octave/minute back and forward from 10 to 200Hz. Amplitude 1mm max constant peak to peak until the crossover frequency where acceleration shall be constant at 5g	Contact Resistance within limits after test	90871 90872 91716 91717 93037 93366 93801 93802	93039 93050 93051 91780 93070 93367 93616 93617	93071 93072 93073 93334 93339 93385 93466 93465
6.6	Drop Shock (IEC 60068-2-27)	1/2 sine, 50G, 11 milliseconds 3 shocks in each of 6 directions	Initial contact resistance as per 5.1. Final contact resistance $\leq$ twice the initial contact resistance. No discontinuities greater than 1.0 microsecond	90871 90872 91716 91717 93037 93366 93801 93802	93039 93050 93051 91780 93070 93367 93616 93617	93071 93072 93073 93334 93339 93385 93465 93466

Note: Mechanical Performance not applicable to 90873 series

REVISE ON PC ONLY:		TITLE:	APPLIMATE 2.5MM CONNECTOR PRODUCT SPECIFICATION		
<b>S</b>	SEE SHEET 1				
THIS DOCUMENT CONTAINS INFORMATION THAT IS PROPRIETARY TO MOLEX INC. AND SHOULD NOT BE USED WITHOUT WRITTEN PERMISSION					
REV.	DESCRIPTION			FILENAME	SHEET
	DOCUMENT NUMBER PS-99020-0040			PS990200040	8 of 24





**7.0 ENVIRONMENTAL PERFORMANCE**

Item	Description	Test Condition	Requirements	Applicable Series
7.1	Life test	See appendix B for Temp / Time Profile. See appendix C for PCB structure.	Indirect through Header: Temp / Time Profile A for 6,000 cycles. Final Rc $\leq$ 2 times initial Rc as per 5.6 at rated current	
			Direct to PCB: Temp / Time Profile A for 6,000 cycles. Final Rc $\leq$ 3 times initial Rc as per 5.6 at rated current	
7.2	Vibration/ Climate Test	300 cycles as temp/time profile Appendix B. Vibrate in chamber as per 6.4 for 100 hrs in each X,Y,Z directions	Final Rc $\leq$ 2 times initial Rc as per 5.1. No Discontinuity greater than 1uSec	
7.3	Damp Heat Test (IEC 60068-2-78)	14 days at 40°C and 93% R.H. No current flow during exposure.	Final Rc $\leq$ 2 times initial Rc as per 5.1	90871 93039 93071
7.4	Thermal Cycling (Ageing test)	14 cycles: one cycle consists of 16 hours at 80°C followed by 8 hours at 20°C maximum		90872 93050 93072
7.5	SO <sub>2</sub> (DIN 50018-0, 0.2S)	T <sub>amb</sub> = +40°C SO <sub>2</sub> = 0.2 liter H <sub>2</sub> O = 2 liter 8 hours exposure time 16 hours recovery time	Final Rc $\leq$ 2 times initial Rc as per 5.1	91716 93051 93073
7.6	Salt Mist Spray (IEC 60068-2-11)	T <sub>amb</sub> = 35°C Rel. Humidity = 95% NaCl concentrate = 50g/ltr Duration 72 Hrs	Final Rc $\leq$ 2 times initial Rc as per 5.1 No internal corrosion traces. Insulation resistance @ 500V as per 5.2	91717 91780 93334
				93037 93070 93339
				93366 93367 93385
				93801 93616 93465
				93802 93617 93466

REVISE ON PC ONLY:		TITLE:	APPLIMATE 2.5MM CONNECTOR PRODUCT SPECIFICATION	
<b>S</b>	SEE SHEET 1			
THIS DOCUMENT CONTAINS INFORMATION THAT IS PROPRIETARY TO MOLEX INC. AND SHOULD NOT BE USED WITHOUT WRITTEN PERMISSION				
REV.	DESCRIPTION			
DOCUMENT NUMBER PS-99020-0040		FILENAME PS990200040	SHEET 9 of 24	



PRODUCT SPECIFICATION



LANGUAGE

English

7.7	Cold Exposure (IEC 60068-2-1) Test Ab	2 hours at -40°C	Final Rc ≤ 2 times initial Rc as per 5.1 No physical damage	90871	93039	93071
7.8	Dry Heat (Storage) (IEC 60068-2-2) Test Bb	85°C for 96 hours	Final Rc ≤ 2 times initial Rc as per 5.1	90872	93050	93072
7.9	Ball Pressure Test (Values taken from Plastic Material Specification)	Test for 1 hour at +125°C	Diameter of footprint not to exceed 2 mm <sup>2</sup>	91716	93051	93073
7.10	Glow Wire Test (IEC60695-2-11)	Connector subject to rated temp glow wire for 30 seconds on X, Y & Z axis. See Appendix F for diagram	Glow wire temp = 650°C. Suitable for < or = 0.2Amps	91717	93070	93073
			Glow wire temp = 750°C. Suitable for > or = 0.2Amps	91780	93037	93339
7.11	Solder-ability Test ** (IEC-60068-2-20)	Solder Temp = 260Deg C. Immersion & Withdrawal speed = 25mm/min +/-10%. Immersion time = 2s	Solder Tail completely wetted. Smooth bright solder. Pin-holes and voids should not be concentrated in one section of wetted area	93072	93334	93367
			N/A	93073	93385	93616

\*\* = This product is to be soldered by Wave Solder process only

Note: Environmental Performance not applicable to 90873 series

8.0 PACKAGING

Parts shall be packaged to protect against damage during handling, transit and storage. No Styrofoam shall be used in any packing that comes in direct contact with the connectors.

REVISE ON PC ONLY:		TITLE:	APPLIMATE 2.5MM CONNECTOR PRODUCT SPECIFICATION	
S	SEE SHEET 1			
THIS DOCUMENT CONTAINS INFORMATION THAT IS PROPRIETARY TO MOLEX INC. AND SHOULD NOT BE USED WITHOUT WRITTEN PERMISSION				
REV.	DESCRIPTION			
DOCUMENT NUMBER PS-99020-0040		FILENAME PS990200040	SHEET 10 of 24	



**9.0 TEST GROUPINGS**

Item	Description	A	B	C	D	E	F	G	H	I	J
4.1	Visual examination	1,3	1,7	1,5	1,9	1,5	1,7	1,5		1,7	1, 5
5.1	Contact Resistance		2,4,6	2,4	2,6	2,4	2,4,6				
5.2	Insulation Resistance				3,7					3,16	
5.3	Voltage proof				4,8						
5.4	Max temp rise								1		
5.5	De-Rating curve								1		
5.6	Contact resistance (1 Amp)							2,4		2,15	2, 4
6.1	Mating Force								1		
6.2	Un-mating Force								1		
6.3	IDT Wire Retention								1		
6.4	Vibration		3								
6.5	Vibration										3
6.6	Drop Shock		5								
7.1	Life Test	2									
7.2	Vibration/Climate Test			3							
7.3	Damp Heat Test				5						
7.4	Thermal Cycling					3					
7.5	SO <sub>2</sub>							3			
7.6	Salt Mist Spray									4	
7.7	Cold Exposure						3				
7.8	Dry heat storage						5				
7.9	Ball Pressure test								1		
7.10	Glow wire test								1		
7.11	Solder-ability Test								1		

REVISE ON PC ONLY:		TITLE:	<p align="center"><b>APPLIMATE 2.5MM CONNECTOR PRODUCT SPECIFICATION</b></p>	
<b>S</b>	SEE SHEET 1			
THIS DOCUMENT CONTAINS INFORMATION THAT IS PROPRIETARY TO MOLEX INC. AND SHOULD NOT BE USED WITHOUT WRITTEN PERMISSION				
REV.	DESCRIPTION	DOCUMENT NUMBER PS-99020-0040		FILENAME PS990200040 SHEET 11 of 24



APPENDIX A

CONTACT RESISTANCE MEASUREMENT

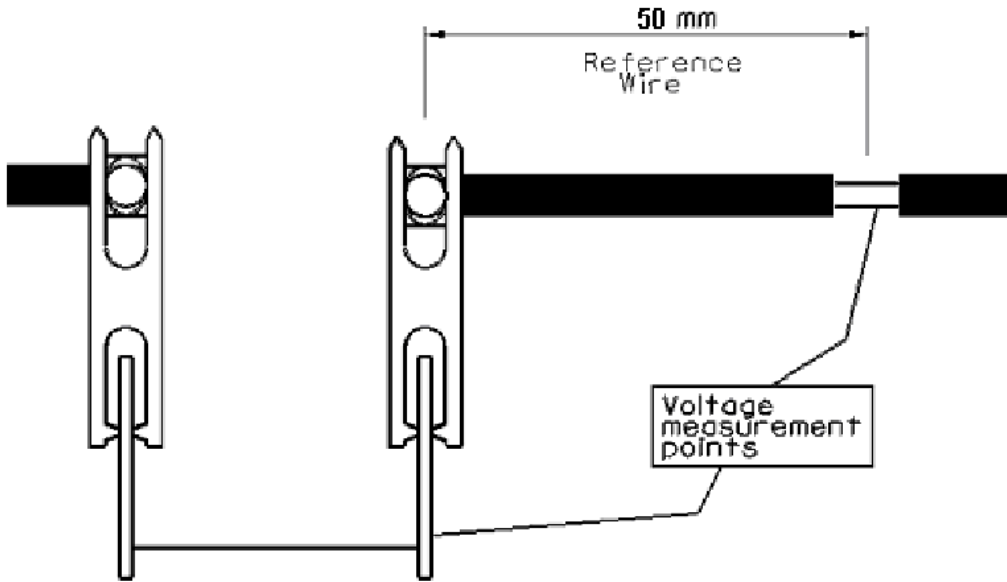

REVISE ON PC ONLY:		TITLE:	APPLIMATE 2.5MM CONNECTOR PRODUCT SPECIFICATION	
<b>S</b>	SEE SHEET 1			
REV.	DESCRIPTION	THIS DOCUMENT CONTAINS INFORMATION THAT IS PROPRIETARY TO MOLEX INC. AND SHOULD NOT BE USED WITHOUT WRITTEN PERMISSION		
DOCUMENT NUMBER PS-99020-0040			FILENAME PS990200040	SHEET 12 of 24



APPENDIX B

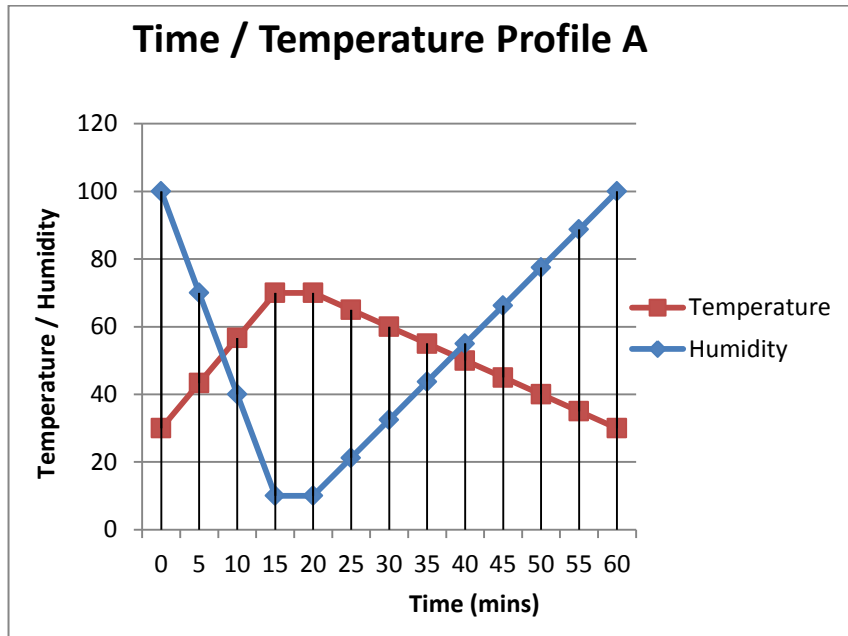

LIFE TEST- TEMPERATURE – TIME PROFILE A

During the 6,000 hours life test, all test specimens must undergo the following:

- Power on at rated current for 0-20 mins, Power Off for 20-60mins
- Contact Resistance Measurements: as per IEC 512, Part 2 Every 100 hours of the life-test. Up to 1000 hr and every 200 hrs of life test for remainder

REVISE ON PC ONLY:		TITLE:	APPLIMATE 2.5MM CONNECTOR PRODUCT SPECIFICATION	
S	SEE SHEET 1			
THIS DOCUMENT CONTAINS INFORMATION THAT IS PROPRIETARY TO MOLEX INC. AND SHOULD NOT BE USED WITHOUT WRITTEN PERMISSION				
REV.	DESCRIPTION	FILENAME	SHEET	
	DOCUMENT NUMBER PS-99020-0040	PS990200040	13 of 24	



APPENDIX C

RECOMMENDED PCB SPECIFICATION

Reference the relevant Sales Drawing for a recommended PCB pad layout.

Material data of the test-PCB:

PCB (single side): CEM1, 1.5mm 70µm Cu; 2mm width of contact pads, 1µm min Sn (HAL).

PCB (single or double sided): FR4, 1.5mm 35-70µm Cu; 2mm width of contact pads 5-20µm Sn (Electro-plated) on both sides.

REVISE ON PC ONLY:		TITLE:	APPLIMATE 2.5MM CONNECTOR PRODUCT SPECIFICATION	
<b>S</b>	SEE SHEET 1			
THIS DOCUMENT CONTAINS INFORMATION THAT IS PROPRIETARY TO MOLEX INC. AND SHOULD NOT BE USED WITHOUT WRITTEN PERMISSION				
REV.	DESCRIPTION			
DOCUMENT NUMBER PS-99020-0040		FILENAME PS990200040	SHEET 14 of 24	



APPENDIX D

**DERATING CURVE RAST 2.5 DIRECT (0.22wire)**

Series 91716 & 91717

Current	Tb	Tu	Delta T	Tm-Delta T	(Current) 20%
0				150.0	0.0
1	<b>28.5</b>	20.5	8.0	142.0	0.8
2	<b>42.7</b>	21.7	21.0	129.0	1.6
3	<b>72.5</b>	22.0	50.5	99.5	2.4
4	<b>98.6</b>	21.5	77.1	72.9	3.2
5	<b>141.2</b>	21.3	119.9	30.1	4.0

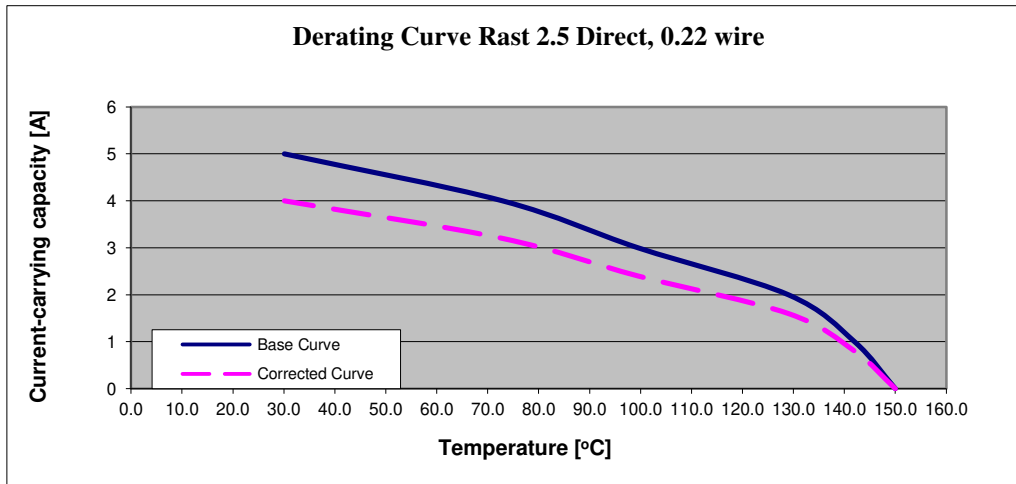

Tb	Measured Temperature
Tu	Room Temperature
Delta T	Tb-Tu
Tm	Upper temp limit of material

REVISE ON PC ONLY:		TITLE:	APPLIMATE 2.5MM CONNECTOR PRODUCT SPECIFICATION	
<b>S</b>	SEE SHEET 1			
THIS DOCUMENT CONTAINS INFORMATION THAT IS PROPRIETARY TO MOLEX INC. AND SHOULD NOT BE USED WITHOUT WRITTEN PERMISSION				
REV.	DESCRIPTION			
DOCUMENT NUMBER PS-99020-0040		FILENAME PS990200040	SHEET 15 of 24	



**DERATING CURVE RAST 2.5 SIDE LATCHED (0.22wire)**

Series 91780

Current	Tb	Tu	Delta T	Tm-Delta T	(Current) 20%
0				125.0	0.0
1	<b>24.0</b>	19.7	4.3	115.7	0.8
2	<b>38.6</b>	20.5	18.1	101.9	1.6
3	<b>61.8</b>	20.4	41.4	78.6	2.4
4	<b>95.4</b>	20.0	75.4	44.6	3.2
5	<b>122.7</b>	20.3	102.4	17.6	4.0

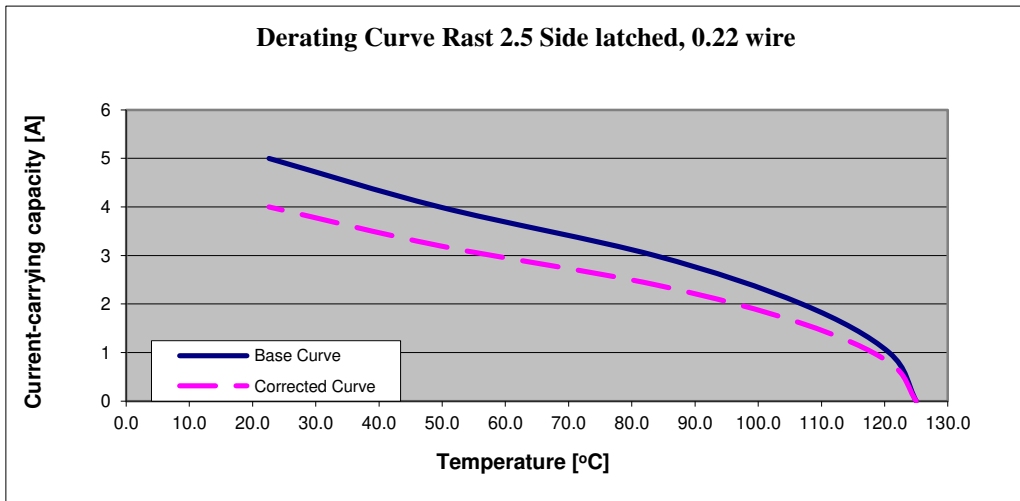

Tb	Measured Temperature
Tu	Room Temperature
Delta T	Tb-Tu
Tm	Upper temp limit of material

REVISE ON PC ONLY:		TITLE:	APPLIMATE 2.5MM CONNECTOR PRODUCT SPECIFICATION	
<b>S</b>	SEE SHEET 1			
THIS DOCUMENT CONTAINS INFORMATION THAT IS PROPRIETARY TO MOLEX INC. AND SHOULD NOT BE USED WITHOUT WRITTEN PERMISSION				
REV.	DESCRIPTION			
DOCUMENT NUMBER PS-99020-0040		FILENAME PS990200040	SHEET 16 of 24	





**DERATING CURVE RAST 2.5 INDIRECT (HEADER 0.22wire)**

Series 91716 & 91717

Current	Tb	Tu	Delta T	Tm-Delta T	(Current) 20%
0				150.0	0.0
1	24.8	22.7	2.1	147.9	0.8
2	32.1	22.7	9.4	140.6	1.6
3	47.3	22.7	24.6	125.4	2.4
4	62.8	22.7	40.1	109.9	3.2
5	82.6	22.8	59.8	90.2	4.0
6	105.4	22.7	82.7	67.3	4.8
7	138.7	22.6	116.1	33.9	5.6
8	153.0	22.7	130.3	19.7	6.4
9	132.3	22.7	109.6	40.4	7.2

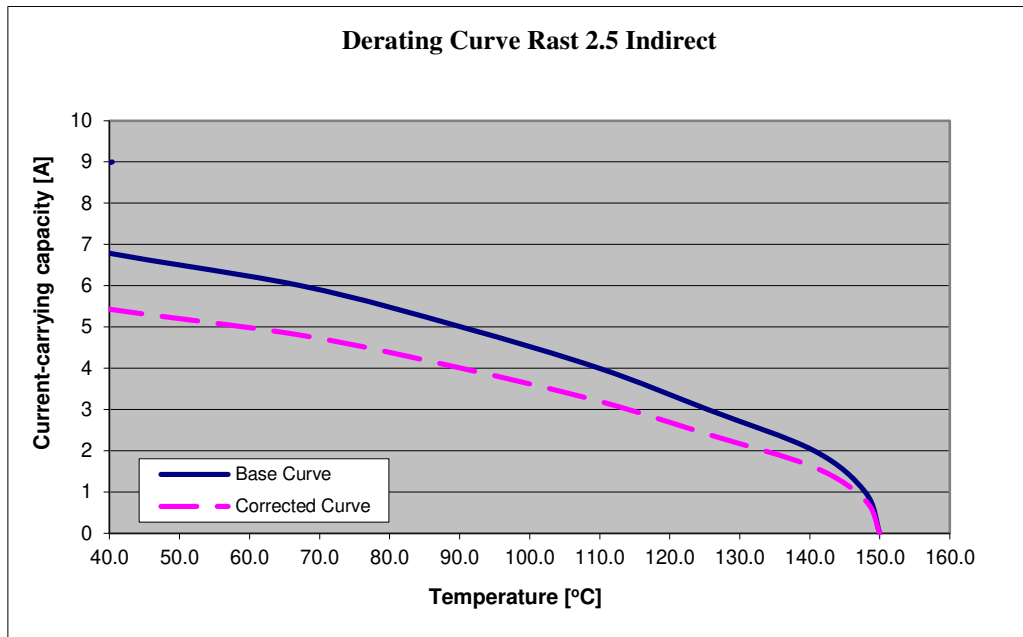

Tb	Measured Temperature
Tu	Room Temperature
Delta T	Tb-Tu
Tm	Upper temp limit of material

REVISE ON PC ONLY:		TITLE:	APPLIMATE 2.5MM CONNECTOR PRODUCT SPECIFICATION	
S	SEE SHEET 1			
THIS DOCUMENT CONTAINS INFORMATION THAT IS PROPRIETARY TO MOLEX INC. AND SHOULD NOT BE USED WITHOUT WRITTEN PERMISSION				
REV.	DESCRIPTION			
DOCUMENT NUMBER PS-99020-0040		FILENAME PS990200040	SHEET 17 of 24	



**DERATING CURVE RAST 2.5 DIRECT (0.38wire)**

Series 91716 & 91717

Current	Tb	Tu	Delta T	Tm-Delta T	(Current) 20%
0				150.0	0.0
1	27.0	21.0	6.0	144.0	0.8
2	41.5	21.1	20.4	129.6	1.6
3	61.0	21.8	39.2	110.8	2.4
4	93.3	20.2	73.1	76.9	3.2
5	136.7	21.6	115.1	34.9	4.0
6	171.2	22.2	149.0	1.0	4.8

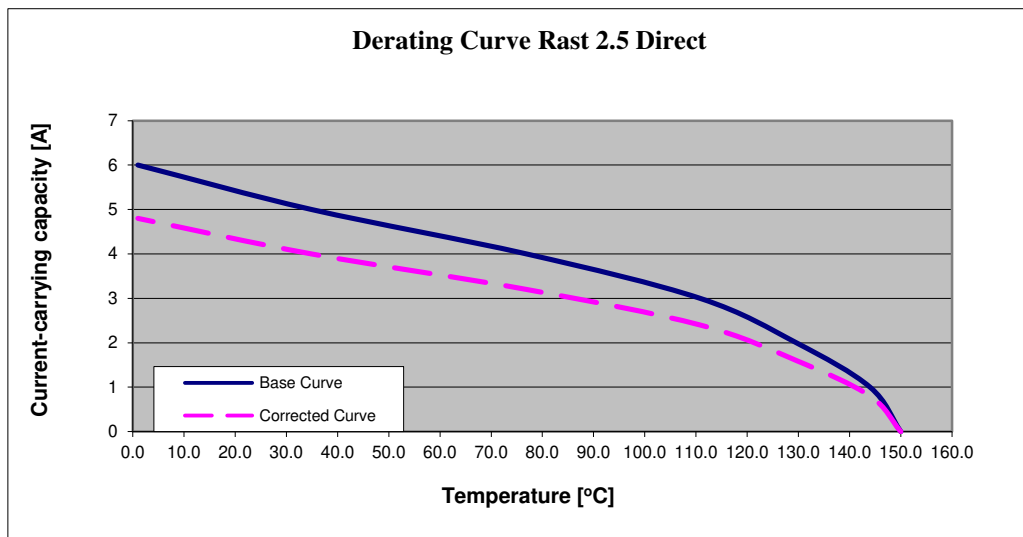

Tb	Measured Temperature
Tu	Room Temperature
Delta T	Tb-Tu
Tm	Upper temp limit of material

REVISE ON PC ONLY:		TITLE:	APPLIMATE 2.5MM CONNECTOR PRODUCT SPECIFICATION	
S	SEE SHEET 1			
THIS DOCUMENT CONTAINS INFORMATION THAT IS PROPRIETARY TO MOLEX INC. AND SHOULD NOT BE USED WITHOUT WRITTEN PERMISSION				
REV.	DESCRIPTION			
DOCUMENT NUMBER PS-99020-0040		FILENAME PS990200040	SHEET 18 of 24	



**DERATING CURVE RAST 2.5 INDIRECT (header 0.38 wire)**

Series 91716 & 91717

Current	Tb	Tu	Delta T	Tm-Delta T	(Current)20%
0				150.0	0.0
1	25.2	21.1	4.1	145.9	0.8
2	28.5	20.4	8.1	141.9	1.6
3	36.3	21.4	14.9	135.1	2.4
4	45.7	21.1	24.6	125.4	3.2
5	59.0	20.4	38.6	111.4	4.0
6	74.3	20.8	53.5	96.5	4.8
7	91.5	21.1	70.4	79.6	5.6
8	112.8	22.8	90.0	60.0	6.4
9	132.3	22.5	109.8	40.2	7.2

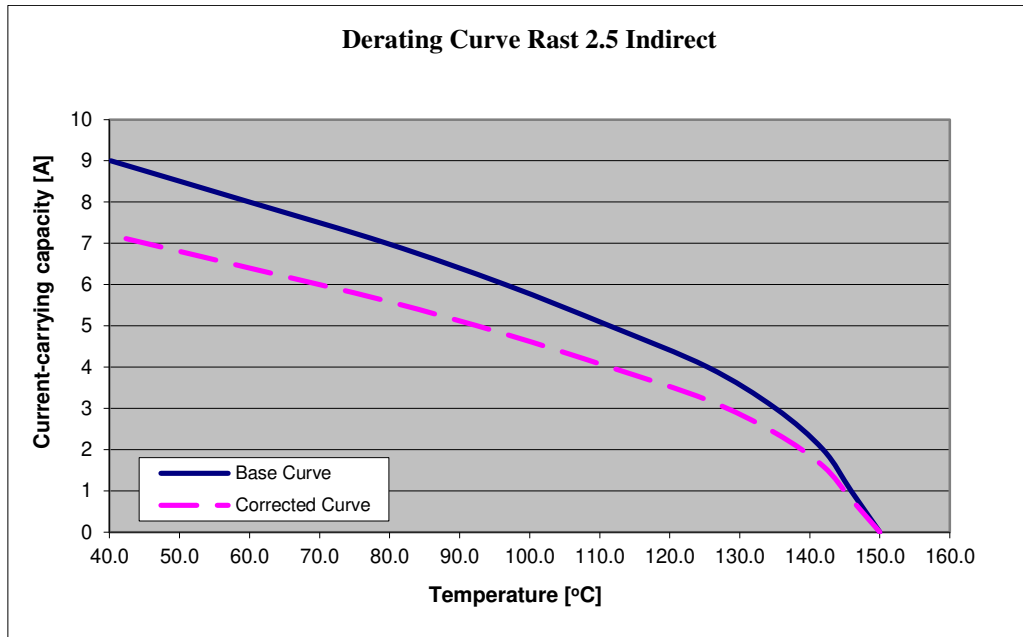

Tb	Measured Temperature
Tu	Room Temperature
Delta T	Tb-Tu
Tm	Upper temp limit of material

<b>S</b>	REVISE ON PC ONLY: SEE SHEET 1	TITLE: <b>APPLIMATE 2.5MM CONNECTOR PRODUCT SPECIFICATION</b>
	REV. DESCRIPTION	THIS DOCUMENT CONTAINS INFORMATION THAT IS PROPRIETARY TO MOLEX INC. AND SHOULD NOT BE USED WITHOUT WRITTEN PERMISSION
DOCUMENT NUMBER PS-99020-0040		FILENAME PS990200040
		SHEET 19 of 24



### DERATING CURVE RAST 2.5 SIDE LATCH (0.38 wire)

Current	Tb	Tu	Delta T	Tm-Delta T	(Current)20%
0				125.0	0.0
1	24.5	20.1	4.4	120.6	0.8
2	41.2	20.9	20.3	104.7	1.6
3	64.1	21.2	42.9	82.1	2.4
4	76.9	20.7	56.2	60.2	3.2
5	123.0	20.6	102.4	22.6	4.0

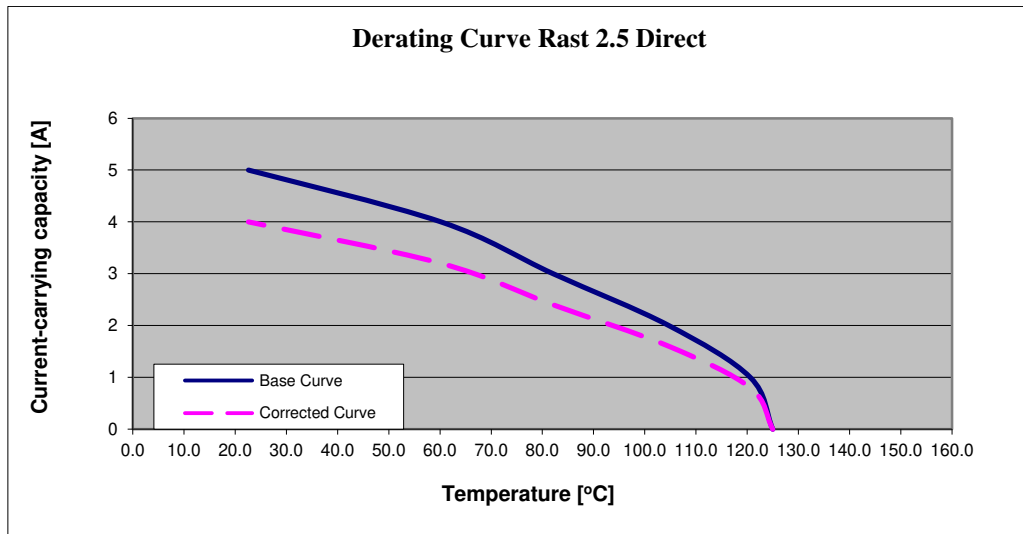

Tb	Measured Temperature
Tu	Room Temperature
Delta T	Tb-Tu
Tm	Upper temp limit of material

REVISE ON PC ONLY:		TITLE:	APPLIMATE 2.5MM CONNECTOR PRODUCT SPECIFICATION	
<b>S</b>	SEE SHEET 1			
THIS DOCUMENT CONTAINS INFORMATION THAT IS PROPRIETARY TO MOLEX INC. AND SHOULD NOT BE USED WITHOUT WRITTEN PERMISSION				
REV.	DESCRIPTION			
DOCUMENT NUMBER PS-99020-0040		FILENAME PS990200040	SHEET 20 of 24	



APPENDIX E

Un-mating force test set-up of Side latch

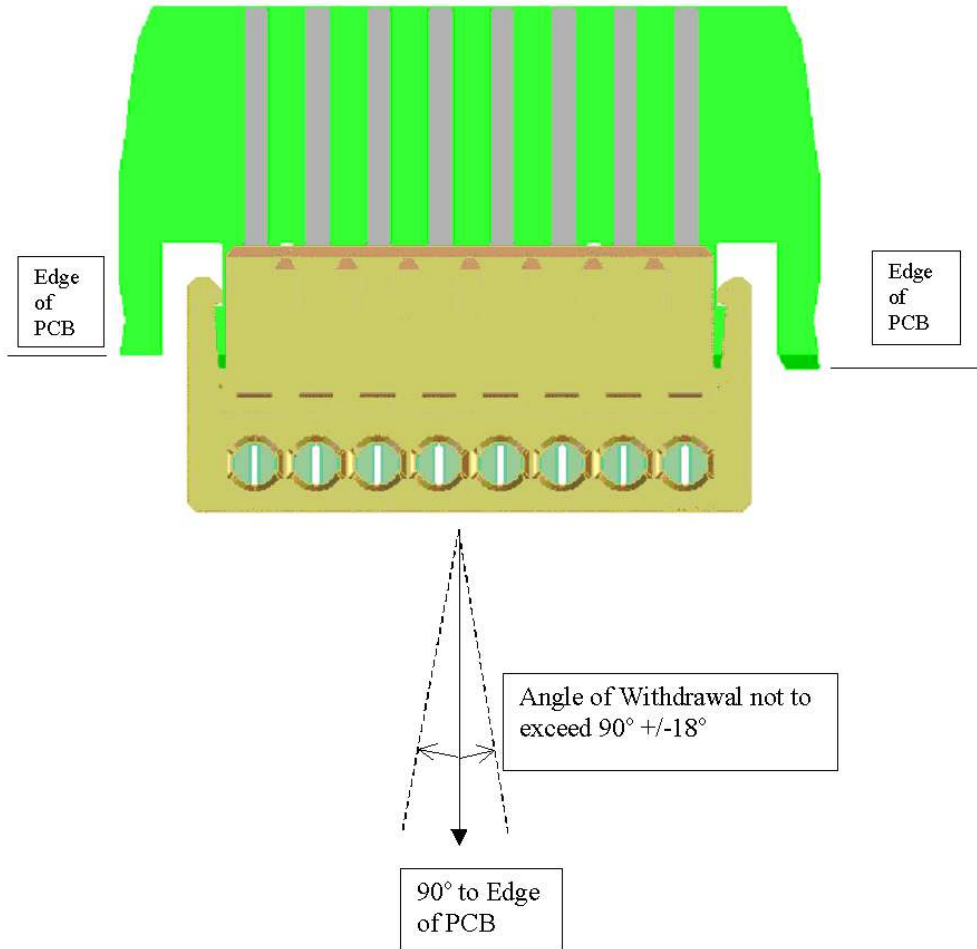

REVISE ON PC ONLY:		TITLE:	APPLIMATE 2.5MM CONNECTOR PRODUCT SPECIFICATION	
S	SEE SHEET 1			
THIS DOCUMENT CONTAINS INFORMATION THAT IS PROPRIETARY TO MOLEX INC. AND SHOULD NOT BE USED WITHOUT WRITTEN PERMISSION				
REV.	DESCRIPTION		FILENAME	SHEET
	DOCUMENT NUMBER PS-99020-0040		PS990200040	21 of 24



APPENDIX F

Glow wire test points

Female Connector

Position 1

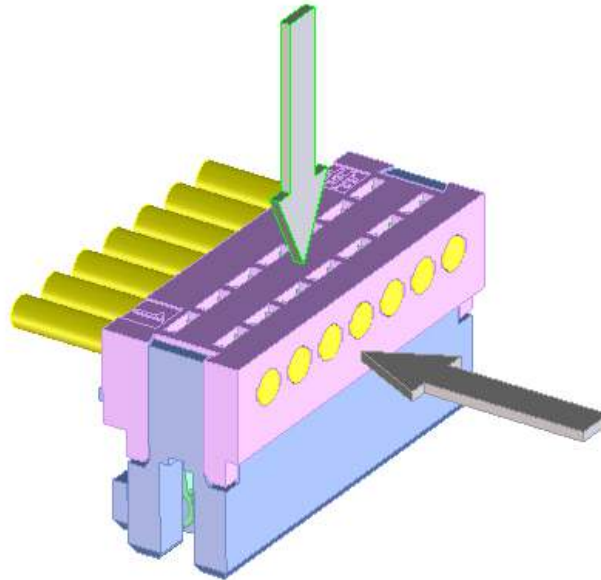

Position 2

Male Connector

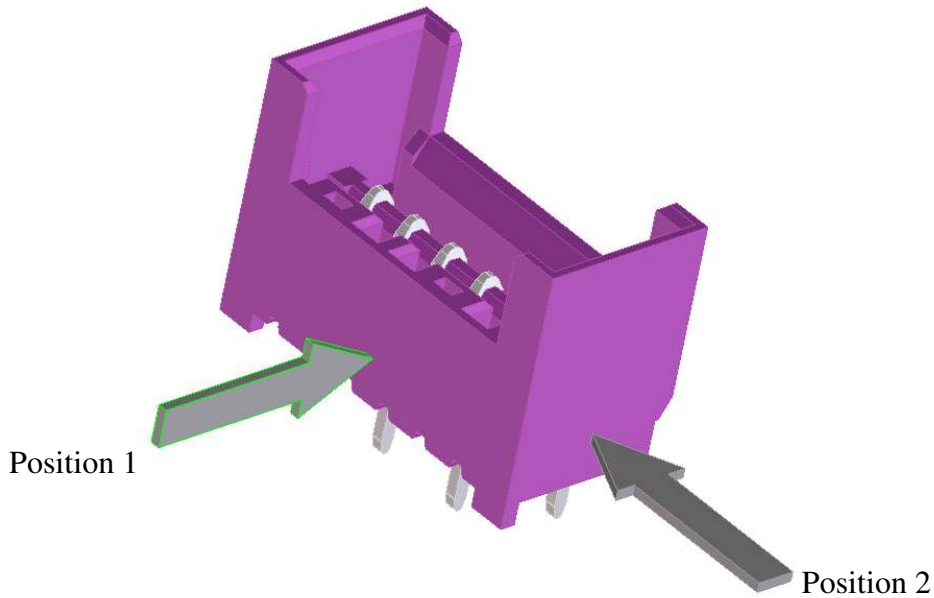

Position 1

Position 2

REVISE ON PC ONLY:		TITLE:	APPLIMATE 2.5MM CONNECTOR PRODUCT SPECIFICATION	
S	SEE SHEET 1			
REV.	DESCRIPTION	THIS DOCUMENT CONTAINS INFORMATION THAT IS PROPRIETARY TO MOLEX INC. AND SHOULD NOT BE USED WITHOUT WRITTEN PERMISSION		
DOCUMENT NUMBER PS-99020-0040			FILENAME PS990200040	SHEET 22 of 24



APPENDIX G

Gauge for mating/unmating test

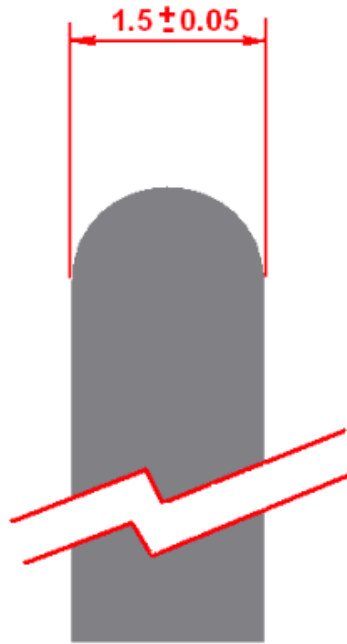

REVISE ON PC ONLY:		TITLE:	APPLIMATE 2.5MM CONNECTOR PRODUCT SPECIFICATION	
S	SEE SHEET 1			
THIS DOCUMENT CONTAINS INFORMATION THAT IS PROPRIETARY TO MOLEX INC. AND SHOULD NOT BE USED WITHOUT WRITTEN PERMISSION				
REV.	DESCRIPTION			
DOCUMENT NUMBER PS-99020-0040		FILENAME PS990200040	SHEET 23 of 24	



**APPENDIX H:**

**IDT wire retention test**

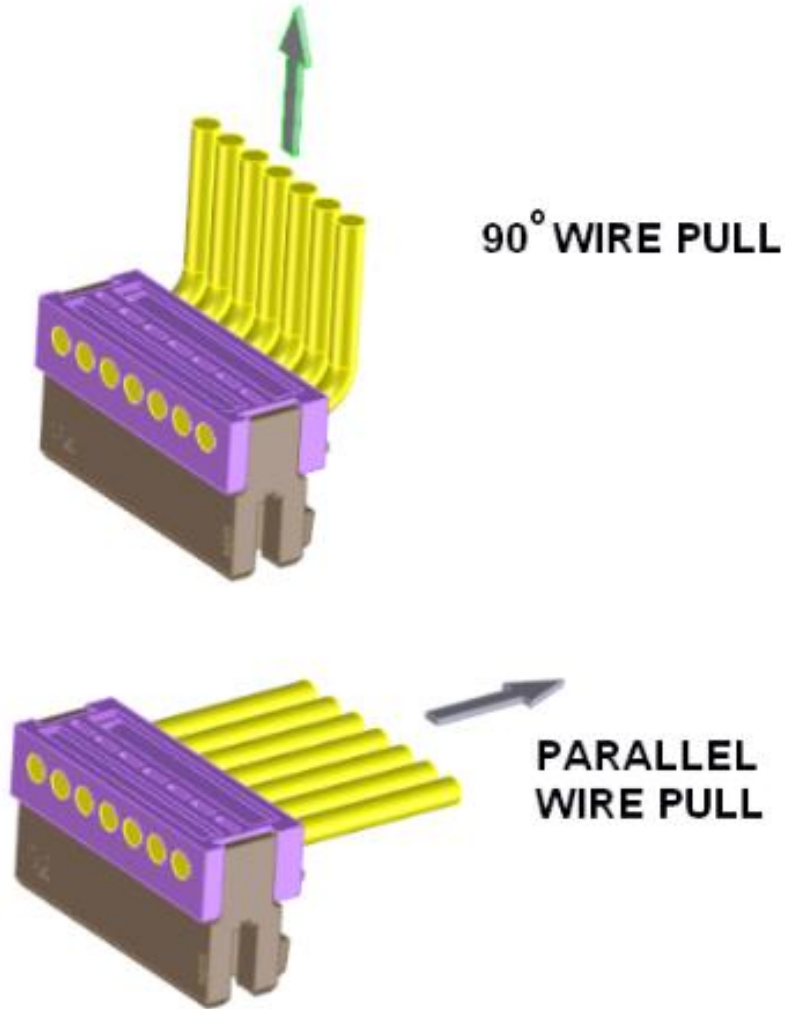

REVISE ON PC ONLY:		TITLE:	APPLIMATE 2.5MM CONNECTOR PRODUCT SPECIFICATION	
<b>S</b>	SEE SHEET 1			
REV.	DESCRIPTION	THIS DOCUMENT CONTAINS INFORMATION THAT IS PROPRIETARY TO MOLEX INC. AND SHOULD NOT BE USED WITHOUT WRITTEN PERMISSION		
DOCUMENT NUMBER PS-99020-0040			FILENAME PS990200040	SHEET 24 of 24