

FEATURES

33 V supply range
Fully specified at +12 V, ±15 V
130 Ω on resistance
No V_L supply required
3 V logic-compatible inputs
Rail-to-rail operation
16-lead TSSOP and 16-lead SOIC
Typical power consumption: <0.03 μW

APPLICATIONS

Signal switching
Battery-powered systems
Communication systems
Audio/video signal routing

GENERAL DESCRIPTION

The ADG1311/ADG1312/ADG1313 are monolithic CMOS devices containing four independently selectable switches designed on a CMOS process.

The ADG1311/ADG1312/ADG1313 contain four independent single-pole/single-throw (SPST) switches. The ADG1311 and ADG1312 differ only in that the digital control logic is inverted. The ADG1311 switches are turned on with Logic 0 on the appropriate control input, while Logic 1 is required for the ADG1312. The ADG1313 has two switches with digital control logic similar to the ADG1311; the logic is inverted on the other two switches. The ADG1313 exhibits break-before-make switching action for use in multiplexer applications.

Each switch conducts equally well in both directions when on and has an input signal range that extends to the supplies. In the off condition, signal levels up to the supplies are blocked.

FUNCTIONAL BLOCK DIAGRAM

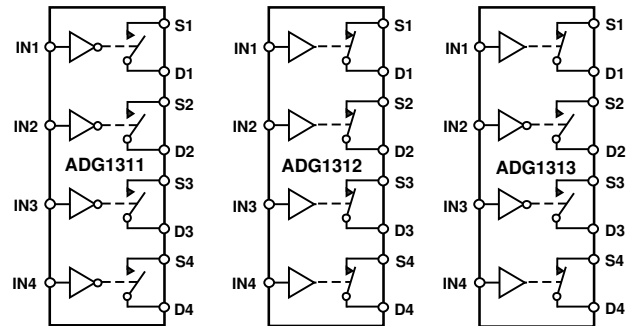

SWITCHES SHOWN FOR A LOGIC 1 INPUT

Figure 1.

09676-001

PRODUCT HIGHLIGHTS

- 3 V logic-compatible digital inputs: $V_{IH} = 2.0$ V, $V_{IL} = 0.8$ V.
- No V_L logic power supply required.
- 16-lead TSSOP and SOIC packages.

Rev. A

Information furnished by Analog Devices is believed to be accurate and reliable. However, no responsibility is assumed by Analog Devices for its use, nor for any infringements of patents or other rights of third parties that may result from its use. Specifications subject to change without notice. No license is granted by implication or otherwise under any patent or patent rights of Analog Devices. Trademarks and registered trademarks are the property of their respective owners.

TABLE OF CONTENTS

Features	1	Absolute Maximum Ratings	5
Applications.....	1	ESD Caution.....	5
Functional Block Diagram	1	Pin Configuration and Function Descriptions.....	6
General Description	1	Terminology	7
Product Highlights	1	Typical Performance Characteristics	8
Specifications.....	3	Test Circuits.....	10
Dual Supply	3	Outline Dimensions	12
Single Supply	4	Ordering Guide	12

REVISION HISTORY

2/09—Rev. 0 to Rev. A

Changes to Power Requirements, I_{DD} , Digital Inputs = 5 V Parameter, Table 1.....	3
Changes to Power Requirements, I_{DD} , Digital Inputs = 5 V Parameter, Table 2.....	4

10/05—Revision 0: Initial Version

SPECIFICATIONS

DUAL SUPPLY

$V_{DD} = 15\text{ V} \pm 10\%$, $V_{SS} = -15\text{ V} \pm 10\%$, $GND = 0\text{ V}$, unless otherwise noted.

Table 1.

Parameter	Y Version ¹		Unit	Test Conditions/Comments
	25°C	-40°C to +105°C		
ANALOG SWITCH				
Analog Signal Range		V_{DD} to V_{SS}	V	
On Resistance (R_{ON})	130	230	Ω typ	$V_S = \pm 10\text{ V}$, $I_S = -1\text{ mA}$; see Figure 10
	200		Ω max	$V_{DD} = +13.5\text{ V}$, $V_{SS} = -13.5\text{ V}$
On Resistance Match Between Channels (ΔR_{ON})	5		Ω typ	$V_S = \pm 10\text{ V}$, $I_S = -1\text{ mA}$
	10		Ω max	
On Resistance Flatness ($R_{FLAT(ON)}$)	25		Ω typ	$V_S = -5\text{ V}/0\text{ V}/+5\text{ V}$; $I_S = -1\text{ mA}$
	65		Ω max	
LEAKAGE CURRENTS				
Source Off Leakage, I_S (Off)	± 10		nA typ	$V_{DD} = +16.5\text{ V}$, $V_{SS} = -16.5\text{ V}$
Drain Off Leakage, I_D (Off)	± 10		nA typ	$V_S = \pm 10\text{ V}$, $V_D = \mp 10\text{ V}$; see Figure 11
Channel On Leakage, I_D , I_S (On)	± 10		nA typ	$V_S = \pm 10\text{ V}$, $V_D = \mp 10\text{ V}$; see Figure 11
				$V_S = V_D = \pm 10\text{ V}$; see Figure 12
DIGITAL INPUTS				
Input High Voltage, V_{INH}		2.0	V min	
Input Low Voltage, V_{INL}		0.8	V max	
Input Current, I_{INL} or I_{INH}	0.005		μA typ	$V_{IN} = V_{INL}$ or V_{INH}
		± 0.1	μA max	
Digital Input Capacitance, C_{IN}	2.5		pF typ	
DYNAMIC CHARACTERISTICS²				
t_{ON}	105		ns typ	$R_L = 300\ \Omega$, $C_L = 35\text{ pF}$
	125	180	ns max	$V_S = 10\text{ V}$; see Figure 13
t_{OFF}	40		ns typ	$R_L = 300\ \Omega$, $C_L = 35\text{ pF}$
	50	60	ns max	$V_S = 10\text{ V}$; see Figure 13
Break-Before-Make Time Delay, t_D (ADG1313 Only)	25	10	ns typ	$R_L = 300\ \Omega$, $C_L = 35\text{ pF}$
			ns min	$V_{S1} = V_{S2} = 10\text{ V}$; see Figure 14
Charge Injection	2		pC typ	$V_S = 0\text{ V}$, $R_S = 0\ \Omega$, $C_L = 1\text{ nF}$; see Figure 15
Off Isolation	80		dB typ	$R_L = 50\ \Omega$, $C_L = 5\text{ pF}$, $f = 1\text{ MHz}$; see Figure 16
Channel-to-Channel Crosstalk	90		dB typ	$R_L = 50\ \Omega$, $C_L = 5\text{ pF}$, $f = 1\text{ MHz}$; see Figure 17
-3 dB Bandwidth	600		MHz typ	$R_L = 50\ \Omega$, $C_L = 5\text{ pF}$; see Figure 18
C_S (Off)	5		pF typ	
C_D (Off)	5		pF typ	
C_D , C_S (On)	10		pF typ	
POWER REQUIREMENTS				
I_{DD}	0.001		μA typ	$V_{DD} = +16.5\text{ V}$, $V_{SS} = -16.5\text{ V}$
		1.0	μA max	Digital inputs = 0 V or V_{DD}
I_{DD}	220		μA typ	Digital inputs = 5 V
		380	μA max	
I_{SS}	0.001		μA typ	Digital inputs = 0 V or V_{DD}
		1.0	μA max	
I_{SS}	0.001		μA typ	Digital inputs = 5 V
		1.0	μA max	

¹ Temperature range for Y Version is -40°C to +105°C.

² Guaranteed by design, not subject to production test.

ADG1311/ADG1312/ADG1313

SINGLE SUPPLY

$V_{DD} = 12\text{ V} \pm 10\%$, $V_{SS} = 0\text{ V}$, $GND = 0\text{ V}$, unless otherwise noted.

Table 2.

Parameter	Y Version ¹		Unit	Test Conditions/Comments
	25°C	–40°C to +105°C		
ANALOG SWITCH				
Analogue Signal Range		0 V to V_{DD}	V	
On Resistance (R_{ON})	325	520	Ω typ	$V_S = 0\text{ V} - 10\text{ V}$, $I_S = -1\text{ mA}$; see Figure 10
	500		Ω max	$V_{DD} = 10.8\text{ V}$, $V_{SS} = 0\text{ V}$
On Resistance Match Between Channels (ΔR_{ON})	10		Ω typ	$V_S = 0\text{ V} - 10\text{ V}$, $I_S = -1\text{ mA}$
	15		Ω max	
On Resistance Flatness ($R_{FLAT(ON)}$)	65		Ω typ	$V_S = 3\text{ V}/6\text{ V}/9\text{ V}$, $I_S = -1\text{ mA}$
LEAKAGE CURRENTS				
Source Off Leakage, I_S (Off)	± 10		nA typ	$V_{DD} = 13.2\text{ V}$, $V_{SS} = 0\text{ V}$
Drain Off Leakage, I_D (Off)	± 10		nA typ	$V_S = 1\text{ V}/10\text{ V}$, $V_D = 10\text{ V}/1\text{ V}$; see Figure 11
Channel On Leakage, I_D , I_S (On)	± 10		nA typ	$V_S = 1\text{ V}/10\text{ V}$, $V_D = 10\text{ V}/1\text{ V}$ see Figure 11
				$V_S = V_D = 1\text{ V}$ or 10 V ; see Figure 12
DIGITAL INPUTS				
Input High Voltage, V_{INH}		2.0	V min	
Input Low Voltage, V_{INL}		0.8	V max	
Input Current, I_{INL} or I_{INH}	0.001		μA typ	$V_{IN} = V_{INL}$ or V_{INH}
		± 0.1	μA max	
Digital Input Capacitance, C_{IN}	3		pF typ	
DYNAMIC CHARACTERISTICS²				
t_{ON}	120		ns typ	$R_L = 300\ \Omega$, $C_L = 35\text{ pF}$
	155	210	ns max	$V_S = 8\text{ V}$; see Figure 13
t_{OFF}	45		ns typ	$R_L = 300\ \Omega$, $C_L = 35\text{ pF}$
	65	80	ns max	$V_S = 8\text{ V}$; see Figure 13
Break-Before-Make Time Delay, t_D (ADG1313 Only)	50	10	ns typ	$R_L = 300\ \Omega$, $C_L = 35\text{ pF}$
			ns min	$V_{S1} = V_{S2} = 8\text{ V}$; see Figure 14
Charge Injection	2		pC typ	$V_S = 6\text{ V}$, $R_S = 0\ \Omega$, $C_L = 1\text{ nF}$; see Figure 15
Off Isolation	80		dB typ	$R_L = 50\ \Omega$, $C_L = 5\text{ pF}$, $f = 1\text{ MHz}$; see Figure 16
Channel-to-Channel Crosstalk	90		dB typ	$R_L = 50\ \Omega$, $C_L = 5\text{ pF}$, $f = 1\text{ MHz}$; see Figure 17
–3 dB Bandwidth	500		MHz typ	$R_L = 50\ \Omega$, $C_L = 5\text{ pF}$; see Figure 18
C_S (Off)	5		pF typ	
C_D (Off)	5		pF typ	
C_D , C_S (On)	10		pF typ	
POWER REQUIREMENTS				
I_{DD}	0.001		μA typ	$V_{DD} = 13.2\text{ V}$
		1.0	μA max	Digital inputs = 0 V or V_{DD}
I_{DD}	220		μA typ	Digital inputs = 5 V
		380	μA max	

¹ Temperature range for Y Version is –40°C to +105°C.

² Guaranteed by design, not subject to production test.

ABSOLUTE MAXIMUM RATINGS

T_A = 25°C, unless otherwise noted.

Table 3.

Parameter	Rating
V _{DD} to V _{SS}	35 V
V _{DD} to GND	−0.3 V to +25 V
V _{SS} to GND	+0.3 V to −25 V
Analog Inputs ¹	V _{SS} − 0.3 V to V _{DD} + 0.3 V or 30 mA, whichever occurs first
Digital Inputs ¹	GND − 0.3 V to V _{DD} + 0.3 V or 30 mA, whichever occurs first
Peak Current, S or D	100 mA (pulsed at 1 ms, 10% duty cycle max)
Continuous Current per Channel, S or D	25 mA
Operating Temperature Range Automotive	−40°C to +105°C
Storage Temperature Range	−65°C to +150°C
Junction Temperature	150°C
16-Lead TSSOP, θ _{JA} Thermal Impedance (4-layer board)	112°C/W
16-Lead SOIC, θ _{JA} Thermal Impedance	77°C/W
Reflow Soldering Peak Temperature, Pb free	260°C

¹ Overvoltages at IN, S, or D are clamped by internal diodes. Current should be limited to the maximum ratings given.

Stresses above those listed under Absolute Maximum Ratings may cause permanent damage to the device. This is a stress rating only; functional operation of the device at these or any other conditions above those indicated in the operational section of this specification is not implied. Exposure to absolute maximum rating conditions for extended periods may affect device reliability.

Table 4. ADG1311/ADG1312 Truth Table

ADG1311 INx	ADG1312 INx	Switch Condition
0	1	On
1	0	Off

Table 5. ADG1313 Truth Table

ADG1313 INx	Switch 1, 4	Switch 2, 3
0	Off	On
1	On	Off

ESD CAUTION

ESD (electrostatic discharge) sensitive device. Electrostatic charges as high as 4000V readily accumulate on the human body and test equipment and can discharge without detection. Although this product features proprietary ESD protection circuitry, permanent damage may occur on devices subjected to high energy electrostatic discharges. Therefore, proper ESD precautions are recommended to avoid performance degradation or loss of functionality.



ADG1311/ADG1312/ADG1313

PIN CONFIGURATION AND FUNCTION DESCRIPTIONS

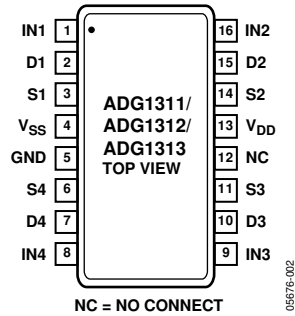

Figure 2. SOIC/TSSOP Pin Configuration

Table 6. Pin Function Descriptions

Pin No.	Mnemonic	Description
1	IN1	Logic Control Input.
2	D1	Drain Terminal. Can be an input or output.
3	S1	Source Terminal. Can be an input or output.
4	V _{SS}	Most Negative Power Supply Potential.
5	GND	Ground (0 V) Reference.
6	S4	Source Terminal. Can be an input or output.
7	D4	Drain Terminal. Can be an input or output.
8	IN4	Logic Control Input.
9	IN3	Logic Control Input.
10	D3	Drain Terminal. Can be an input or output.
11	S3	Source Terminal. Can be an input or output.
12	NC	No Connection.
13	V _{DD}	Most Positive Power Supply Potential.
14	S2	Source Terminal. Can be an input or output.
15	D2	Drain Terminal. Can be an input or output.
16	IN2	Logic Control Input.

TERMINOLOGY

I_{DD}

The positive supply current.

I_{SS}

The negative supply current.

$V_D (V_S)$

The analog voltage on Terminal D and Terminal S.

R_{ON}

The ohmic resistance between D and S.

$R_{FLAT(ON)}$

Flatness is defined as the difference between the maximum and minimum value of on resistance, as measured over the specified analog signal range.

$I_S (Off)$

The source leakage current with the switch off.

$I_D (Off)$

The drain leakage current with the switch off.

$I_D, I_S (On)$

The channel leakage current with the switch on.

V_{INL}

The maximum input voltage for Logic 0.

V_{INH}

The minimum input voltage for Logic 1.

$I_{INL} (I_{INH})$

The input current of the digital input.

$C_S (Off)$

The off switch source capacitance, measured with reference to ground.

$C_D (Off)$

The off switch drain capacitance, measured with reference to ground.

$C_D, C_S (On)$

The on switch capacitance, measured with reference to ground.

C_{IN}

The digital input capacitance.

t_{ON}

The delay between applying the digital control input and the output switching on. See Figure 13.

t_{OFF}

The delay between applying the digital control input and the output switching off. See Figure 13.

Charge Injection

A measure of the glitch impulse transferred from the digital input to the analog output during switching.

Off Isolation

A measure of unwanted signal coupling through an off switch.

Crosstalk

A measure of unwanted signal that is coupled through from one channel to another as a result of parasitic capacitance.

Bandwidth

The frequency at which the output is attenuated by 3 dB.

On Response

The frequency response of the on switch.

Insertion Loss

The loss due to the on resistance of the switch.

TYPICAL PERFORMANCE CHARACTERISTICS

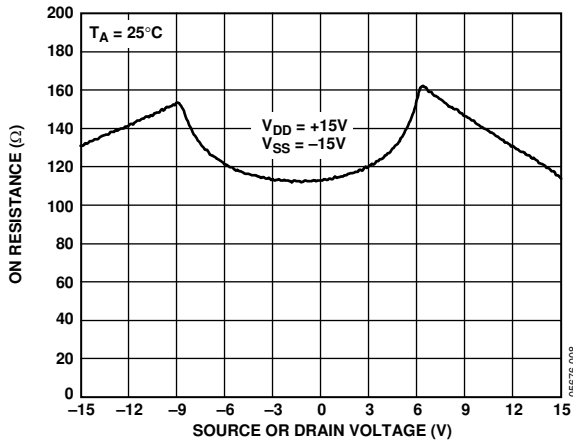

Figure 3. On Resistance as a Function of V_D (V_S) for Dual Supply

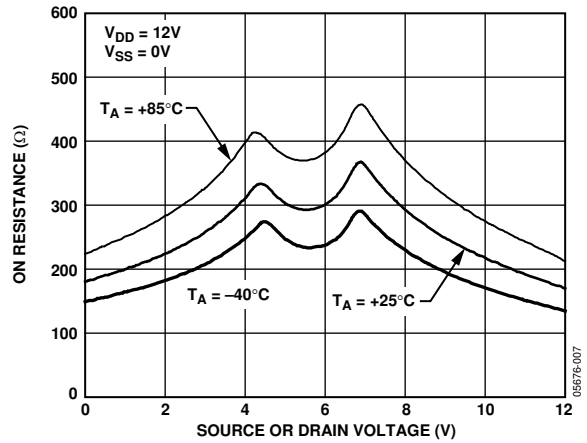

Figure 6. On Resistance as a Function of V_D (V_S) for Different Temperatures, Single Supply

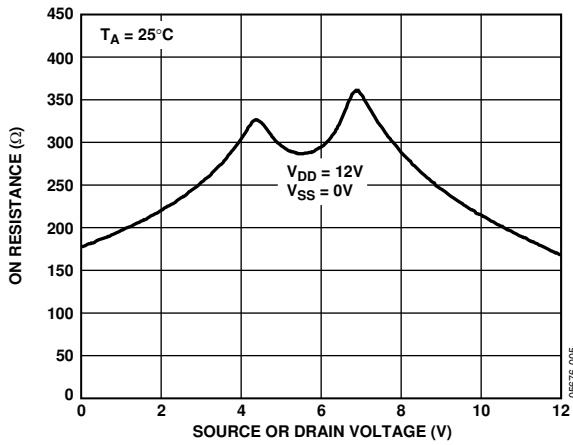

Figure 4. On Resistance as a Function of V_D (V_S) for Single Supply

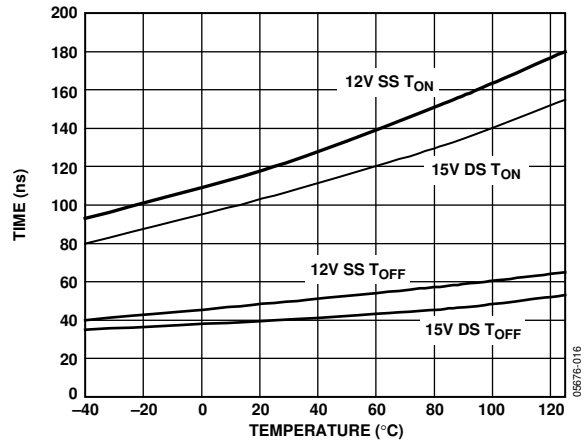

Figure 7. T_{ON}/T_{OFF} Times vs. Temperature

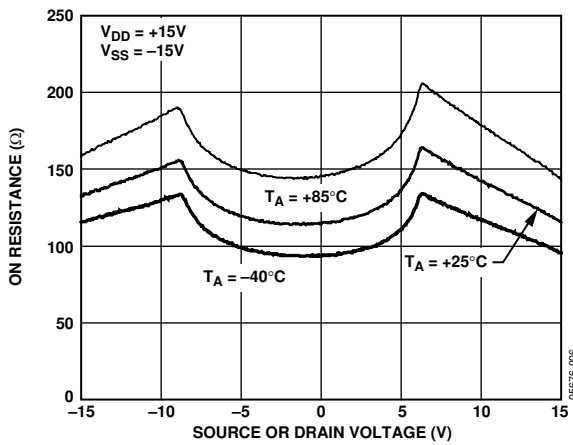

Figure 5. On Resistance as a Function of V_D (V_S) for Different Temperatures, Dual Supply

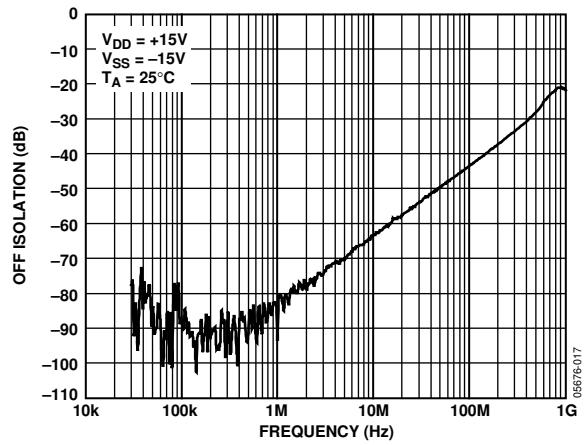

Figure 8. Off Isolation vs. Frequency

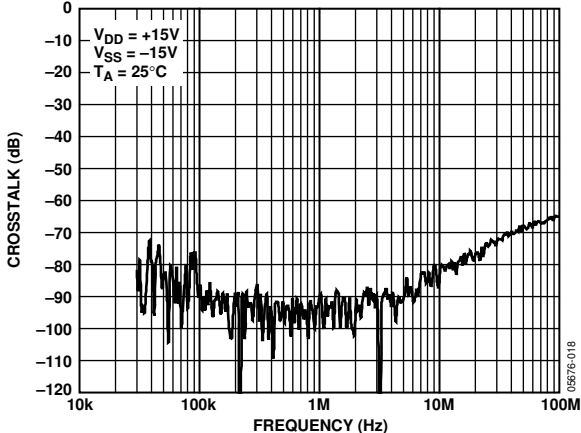

Figure 9. Crosstalk vs. Frequency

TEST CIRCUITS

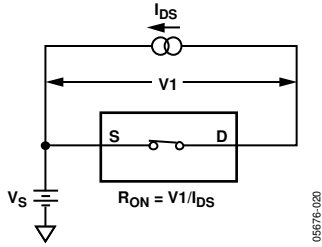

Figure 10. On Resistance

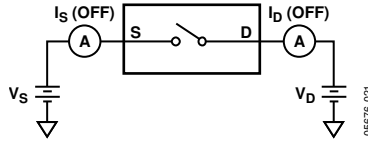

Figure 11. Off Leakage

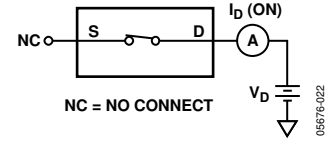

Figure 12. On Leakage

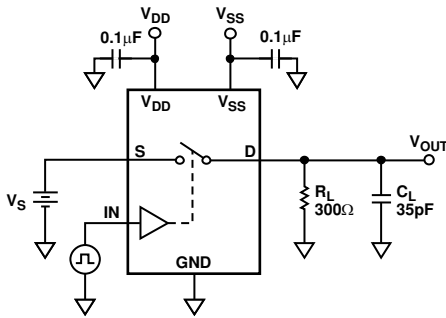

Figure 13. Switching Times

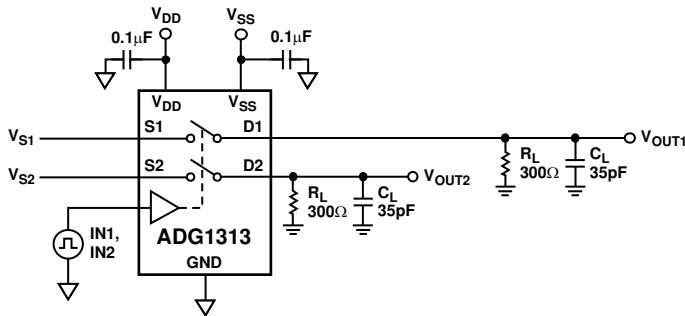

Figure 14. Break-Before-Make Time Delay

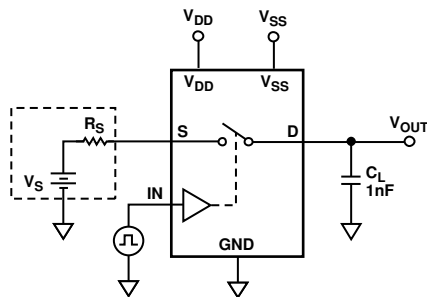

Figure 15. Charge Injection

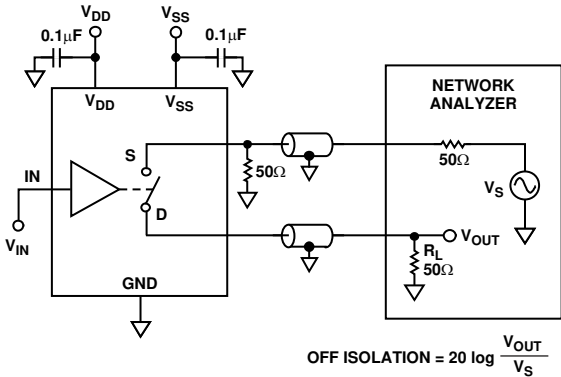

Figure 16. Off Isolation

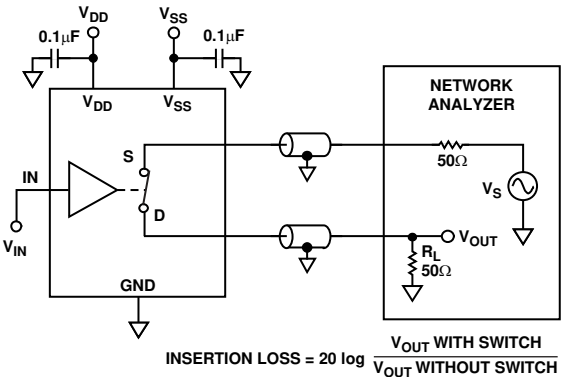

Figure 18. Bandwidth

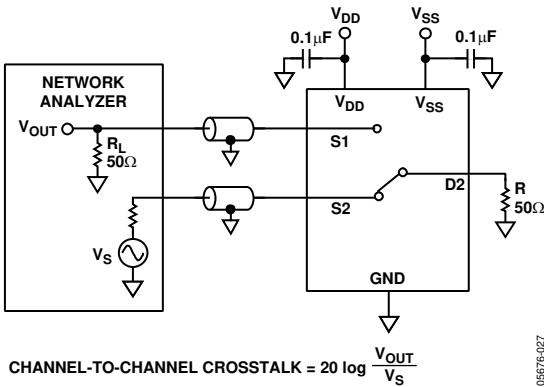

Figure 17. Channel-to-Channel Crosstalk

05676-026

05676-028

05676-027

OUTLINE DIMENSIONS

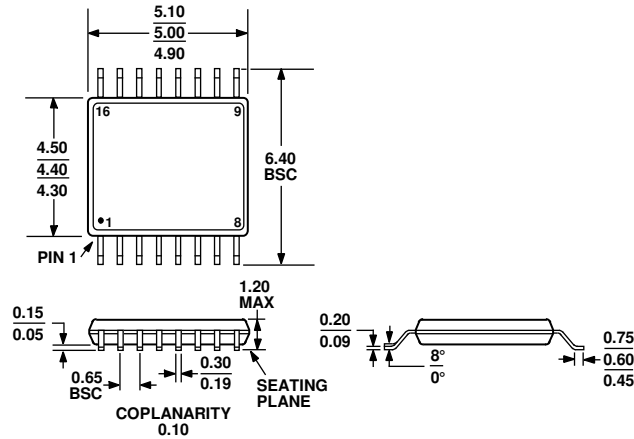

COMPLIANT TO JEDEC STANDARDS MO-153-AB

Figure 19. 16-Lead Thin Shrink Small Outline Package [TSSOP]
(RU-16)

Dimensions shown in millimeters

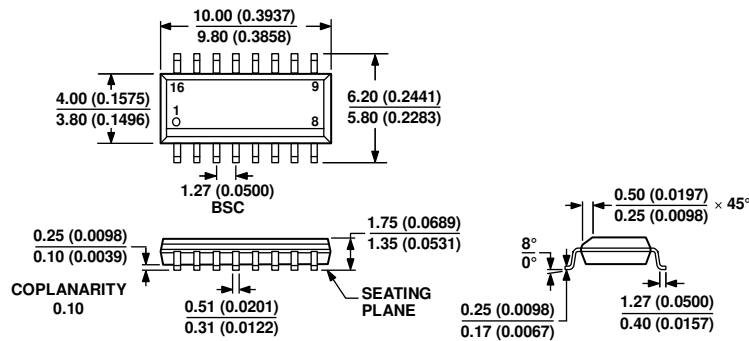

COMPLIANT TO JEDEC STANDARDS MS-012-AC

CONTROLLING DIMENSIONS ARE IN MILLIMETERS; INCH DIMENSIONS (IN PARENTHESES) ARE ROUNDED-OFF MILLIMETER EQUIVALENTS FOR REFERENCE ONLY AND ARE NOT APPROPRIATE FOR USE IN DESIGN.

Figure 20. 16-Lead Standard Small Outline Package [SOIC_N]
Narrow Body (R-16)

Dimensions shown in millimeters and (inches)

060606-A

ORDERING GUIDE

Model	Temperature Range	Package Description	Package Option
ADG1311YRUZ ¹	-40°C to +105°C	16-Lead Thin Shrink Small Outline Package [TSSOP]	RU-16
ADG1311YRUZ-REEL7 ¹	-40°C to +105°C	16-Lead Thin Shrink Small Outline Package [TSSOP]	RU-16
ADG1311YRZ ¹	-40°C to +105°C	16-Lead Narrow Body Small Outline Package [SOIC_N]	R-16
ADG1311YRZ-REEL7 ¹	-40°C to +105°C	16-Lead Narrow Body Small Outline Package [SOIC_N]	R-16
ADG1312YRUZ ¹	-40°C to +105°C	16-Lead Thin Shrink Small Outline Package [TSSOP]	RU-16
ADG1312YRUZ-REEL7 ¹	-40°C to +105°C	16-Lead Thin Shrink Small Outline Package [TSSOP]	RU-16
ADG1312YRZ ¹	-40°C to +105°C	16-Lead Narrow Body Small Outline Package [SOIC_N]	R-16
ADG1312YRZ-REEL7 ¹	-40°C to +105°C	16-Lead Narrow Body Small Outline Package [SOIC_N]	R-16
ADG1313YRUZ ¹	-40°C to +105°C	16-Lead Thin Shrink Small Outline Package [TSSOP]	RU-16
ADG1313YRUZ-REEL7 ¹	-40°C to +105°C	16-Lead Thin Shrink Small Outline Package [TSSOP]	RU-16
ADG1313YRZ ¹	-40°C to +105°C	16-Lead Narrow Body Small Outline Package [SOIC_N]	R-16
ADG1313YRZ-REEL7 ¹	-40°C to +105°C	16-Lead Narrow Body Small Outline Package [SOIC_N]	R-16

¹ Z = RoHS Compliant Part.