



American Opto Plus LED Corp.

L955LYQPGLEC

3.5 x 2.8 x 1.8 mm RGY SMD LED

PACKAGE OUTLINES

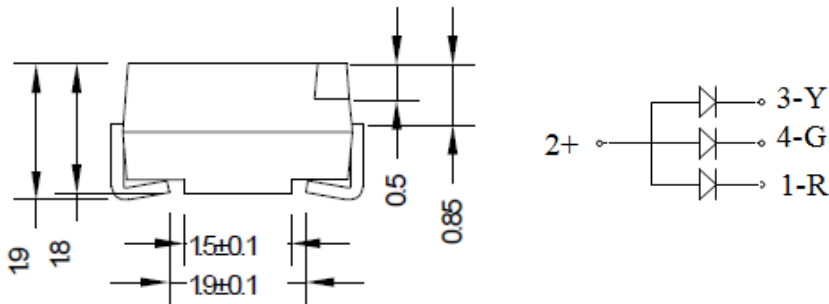
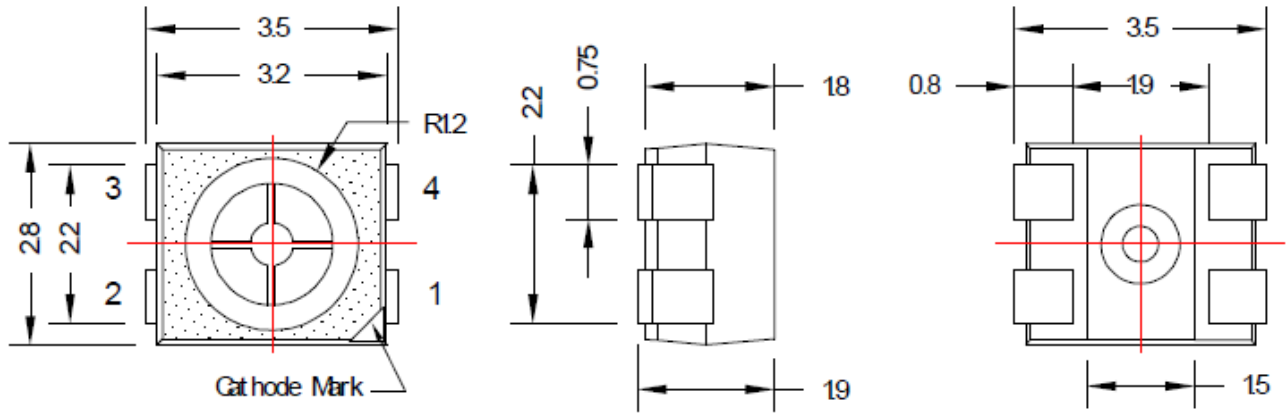

Unit:mm
GENERAL TOL ±0.05

Item	Materials
Package	Heat-Resistant Polymer(Black Face)
Encapsulating Resin	Silicone
Electrodes	Ag Plating Copper Alloy

Notes:

1. All dimensions in mm.
2. Electrical connections between all cathodes are recommended.

Part Number	Material	Lens Color	
		Emitted	Lens
L955LYQPGLEC	AlGaInP	Red	Water Clear
	InGaN	Green	
	AlInGaP/GaAs	Yellow	



American Opto Plus LED Corp.

L955LYQPGLEC

3.5 x 2.8 x 1.8 mm RGY SMD LED

ABSOLUTE MAXIMUM RATINGS

(Ta=25°C)

Parameter	Symbol	Ratings		Unit
DC Forward Current	If	R	30	mA
		G	25	
		Y	30	
Peak Forward Current (Duty 1/10@1KHZ)	Ifp	R	100	mA
		G	100	
		Y	100	
Power Dissipation Single Color	Pd	R	72	mW
		G	90	
		Y	72	
Total Power Dissipation	Ptot	250		V
Human Body Mode	Hbm	>1000		mW
Reverse Voltage	Vr	5		V
Operating Temperature	Topr	-40~+85		°C
Storage Temperature	Tstg	-40~+100		°C
Soldering Temperature	Tsol	Reflow Soldering: 260°C for 5 sec. Hand Soldering: 350°C for 3 sec.		

Ifp conditions: Pulse width ≤ 10msec, and duty ≤ 1/10

Value for total power dissipation when two or more device are lit simultaneously.



American Opto Plus LED Corp.

L955LYQPGLEC

3.5 x 2.8 x 1.8 mm RGY SMD LED

OPTICAL-ELECTRICAL CHARACTERISTICS

(Ta=25°C)

Parameter	Test Condition	Test Condition	Min	Typ	Max	Unit	
Forward Voltage	I _F =20mA	V _f	R	--	2.0	2.4	V
			G	--	3.2	3.6	
			Y	--	2.0	2.4	
Reverse Current	I _F =20mA	I _r	R	--	--	10	uA
			G	--	--	10	
			Y	--	--	50	
Luminous Intensity	I _F =20mA	I _v	R	250	400	--	mcd
			G	700	1200	--	
			Y	250	400	--	
Luminous Flux	I _F =20mA	∅V	R	--	1.2	--	lm
			G	--	3.8	--	
			Y	--	1.1	--	
Dominant Wavelength	I _F =20mA	λ _d	R	--	630	--	nm
			G	--	525	--	
			Y	--	590	--	
Viewing Angle	I _F =20mA	2∅1/2	--	120	--	deg	



American Opto Plus LED Corp.

L955LYQPGLEC

3.5 x 2.8 x 1.8 mm RGY SMD LED

TYPICAL ELECTRO-OPTICAL CHARACTERISTIC CURVES

Forward Current vs. Forward Voltage

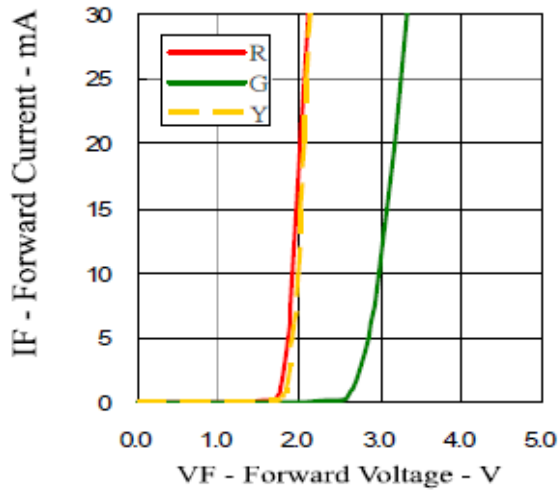

Relative Intensity vs. Forward Current

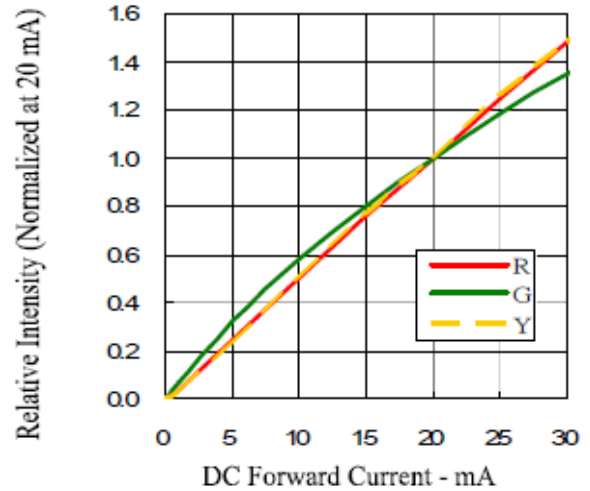

Forward Current vs. Ambient Temperature

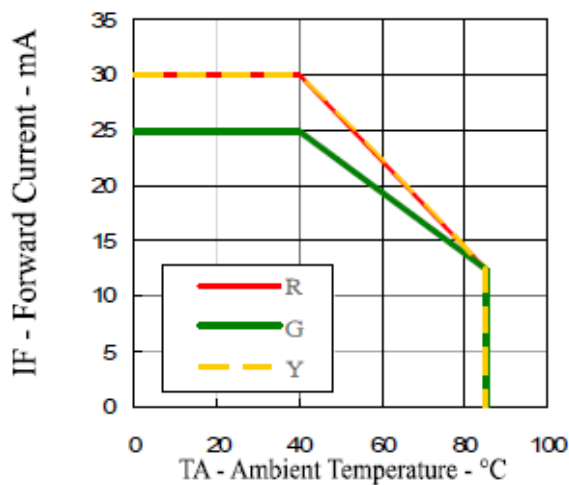

Relative Intensity vs. Wavelength

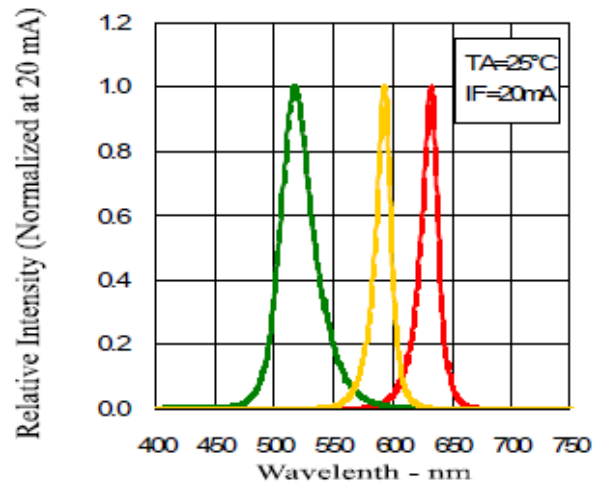



American Opto Plus LED Corp.

L955LYQPGLEC

3.5 x 2.8 x 1.8 mm RGY SMD LED

RADIATION PATTERN

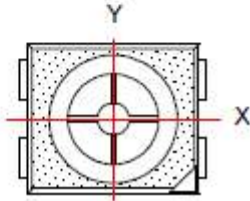
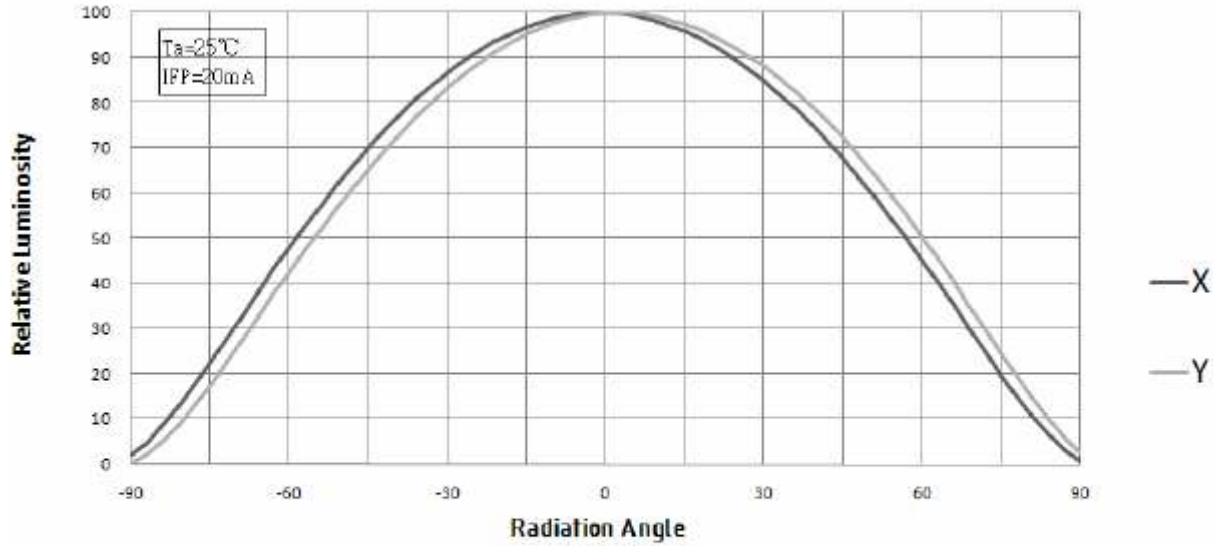

RECOMMENDED SOLDERING PAD PATTERN

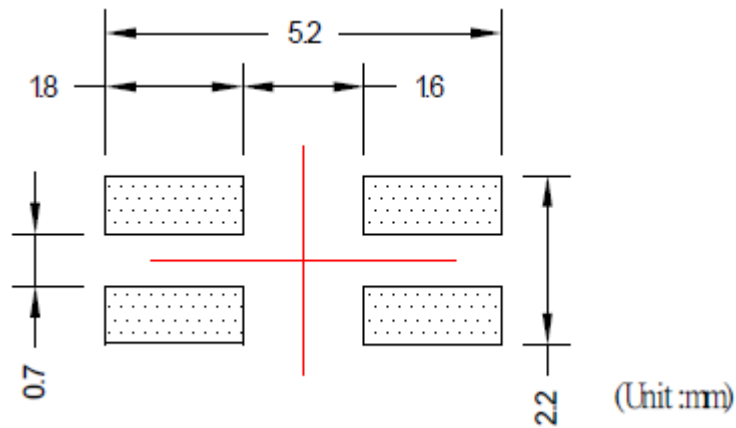



American Opto Plus LED Corp.

L955LYQPGLEC

3.5 x 2.8 x 1.8 mm RGY SMD LED

SOLDERING CONDITIONS

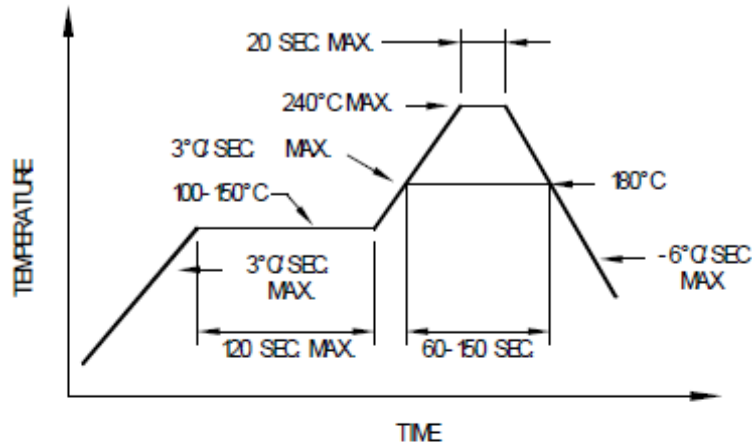

Recommended reflow soldering profile

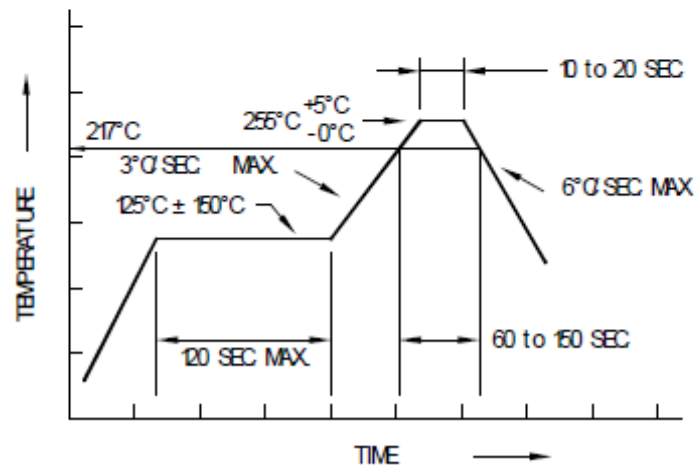

Recommended Pb-free reflow soldering profile

- Repairing should not be done after the LEDs have been soldered. When repairing is unavoidable, a double-head soldering iron should be used. It should be confirmed beforehand whether the characteristics of the LEDs will or will not be damaged by repairing.
- Reflow soldering should not be done more than two times.
- When soldering, do not put stress on the LEDs during heating.
- After soldering, do not warp the circuit board.



American Opto Plus LED Corp.

L955LYQPGLEC

3.5 x 2.8 x 1.8 mm RGY SMD LED

TAPE DIMENSIONS

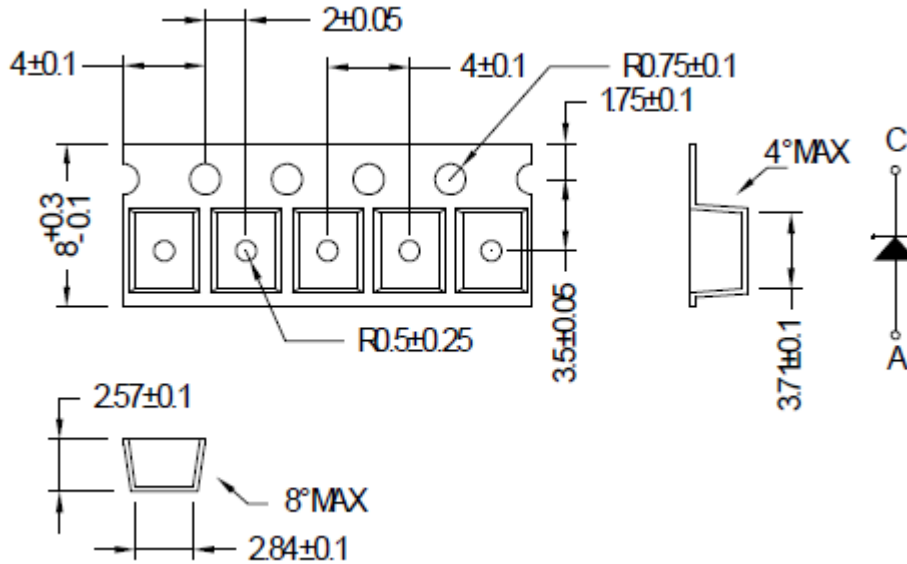

TAPE LEADER AND TRAILER DIMENSIONS

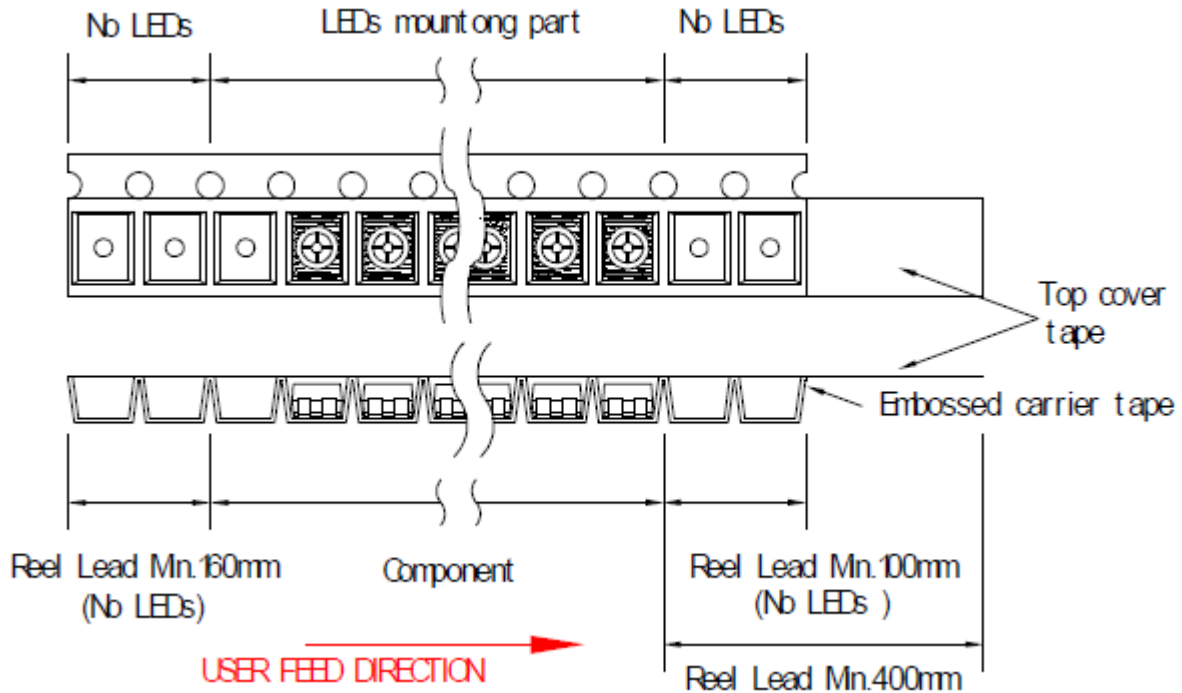



American Opto Plus LED Corp.

L955LYQPGLEC

3.5 x 2.8 x 1.8 mm RGY SMD LED

REEL DIMENSIONS

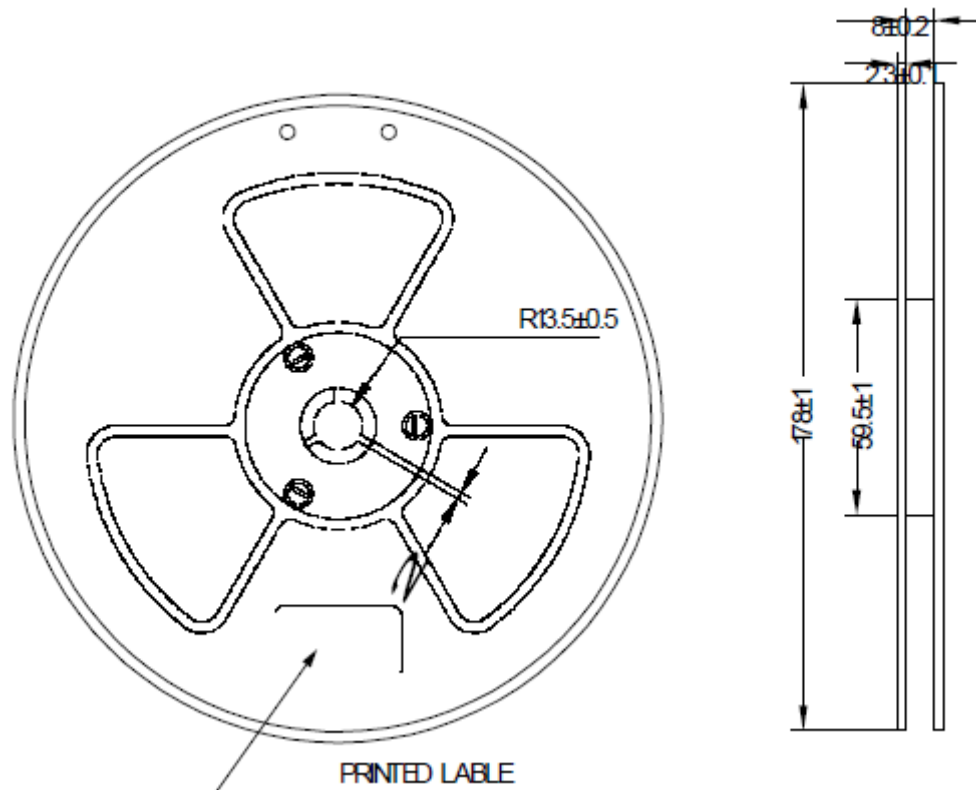

Notes:

1. Baking is required under the following conditions: The pack has been opened for more than four weeks.
2. Baking recommended conditions: $60 \pm 5^\circ\text{C}$ for 20 hours.
3. Reel size: 2000 pcs/reel