

Device Features

- OIP3 = 37.0 dBm @ 900 MHz
- Gain = 17.1 dB @ 900 MHz
- Output P1 dB = 20.9 dBm @ 900 MHz
- Typical 3.0dB NF at 900MHz
- Patented temperature compensation
- RoHS2-compliant SOT-89 SMT package



Product Description

BeRex's BG12B is a high performance InGaP/ GaAs HBT MMIC amplifier, internally matched to 50 Ohms and uses a patented **temperature compensation** circuit to provide stable current over the operating temperature range without the need for external components. The BG12B is designed for high linearity gain block applications that require excellent gain flatness. It is packaged in a RoHS2-compliant with SOT-89 surface mount package.

Applications

- Base station Infrastructure/RFID
- Commercial/Industrial/Military wireless system

Applications Circuit

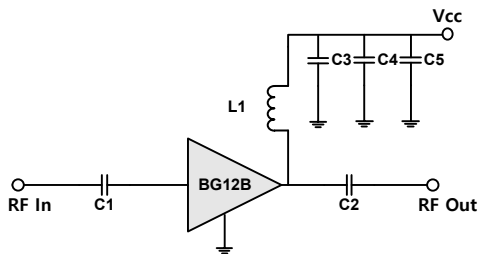

*C1, C2, C3 = 100 pF ± 5%, C4 = 1000pF ± 5%, C5 = 10uF, L1 = 100nH ± 5%

*39nH or higher value L1 improves RF performance at under 3GHz.

*Optimum value of L1 may vary with board design.

(L1:100nH, C1&C2:1.2nF for 70MHz)

Electrical Specifications

Device performance _ measured on a BeRex evaluation board at 25°C, Vc=5V, 50 Ω system.

| Parameter | Conditions | Min | Typ | Max | Unit |
|-----------------------------|-------------------------|------|-------|------|------|
| Operational Frequency Range | | 50 | | 4000 | MHz |
| Test Frequency | | | 900 | | MHz |
| Gain | | 15.6 | 17.1 | | dB |
| Input Return Loss | | | -18.3 | | dB |
| Output Return Loss | | | -14.4 | | dB |
| Output IP3 | 5 dBm / tone , Δf=1 MHz | 34.0 | 37.0 | | dBm |
| Output P1dB | | 19.9 | 20.9 | | dBm |
| Noise Figure | | | 2.9 | | dB |

Recommended Operating Conditions

| Parameter | Min | Typ | Max | Unit |
|--|-----|--------|------|-------|
| Bandwidth | 50 | | 4000 | MHz |
| I _c @ (V _c = 5V) | 62 | 77 | 92 | mA |
| V _c | 4.0 | 5 | 5.25 | V |
| dG/dT | | -0.003 | | dB/°C |
| R _{TH} | | 50.5 | | °C/W |
| Operating Case Temperature | -40 | | +85 | °C |

Electrical specifications are measured at specified test conditions.

Specifications are not guaranteed over all recommended operating conditions.

Absolute Maximum Ratings

| Parameter | Rating | Unit |
|----------------------|-------------|------|
| Storage Temperature | -55 to +155 | °C |
| Junction Temperature | +170 | °C |
| Supply Voltage | +6.0 | V |
| Supply Current | 120 | mA |
| Input RF Power | 23 | dBm |

Operation of this device above any of these parameters may result in permanent damage.

50-4000 MHz Cascadable InGaP HBT Gain Block

Typical Performance (Vc = 5V, Ic = 77mA, T = 25°C)

| Freq | MHz | 70 | 500 | 900 | 1900 | 2140 | 2450 | 3000 |
|------|-----|------|------|------|------|------|------|------|
| S21 | dB | 18.6 | 17.5 | 17.1 | 15.0 | 14.6 | 13.9 | 12.4 |
| S11 | dB | 16.3 | 18.3 | 17.8 | 19.5 | 20.0 | 17.4 | 9.3 |
| S22 | dB | 14.6 | 14.4 | 14.4 | 15.0 | 16.6 | 20.5 | 15.8 |
| P1 | dBm | 20.1 | 20.6 | 20.9 | 20.0 | 19.2 | 18.3 | 16.9 |
| OIP3 | dBm | 36.5 | 38.0 | 37.0 | 34.5 | 34.0 | 33.0 | 31.0 |
| NF | dB | 2.8 | 3.0 | 2.9 | 3.1 | 3.2 | 3.2 | 3.3 |

Typical Performance (Vc = 4.7 V, Ic = 65mA, Ta = 25°C)

| Freq | MHz | 70 | 500 | 900 | 1900 | 2140 | 2450 | 3000 |
|------|-----|------|------|------|------|------|------|------|
| S21 | dB | 18.6 | 17.5 | 17.1 | 15.0 | 14.5 | 13.8 | 12.4 |
| S11 | dB | 16.4 | 18.8 | 18.2 | 19.7 | 20.0 | 17.3 | 9.3 |
| S22 | dB | 14.8 | 14.5 | 14.5 | 14.8 | 16.3 | 20.0 | 16.1 |
| P1 | dBm | 18.9 | 19.3 | 19.5 | 18.8 | 18.4 | 17.6 | 16.4 |
| OIP3 | dBm | 36.0 | 36.0 | 35.0 | 32.5 | 33.0 | 32.0 | 30.5 |
| NF | dB | 2.7 | 2.9 | 2.8 | 3.0 | 3.1 | 3.1 | 3.2 |

Typical Performance (Vc = 4.5 V, Ic = 58mA, Ta = 25°C)

| Freq | MHz | 70 | 500 | 900 | 1900 | 2140 | 2450 | 3000 |
|------|-----|------|------|------|------|------|------|------|
| S21 | dB | 18.5 | 17.4 | 17.0 | 14.9 | 14.5 | 13.8 | 12.3 |
| S11 | dB | 16.6 | 19.2 | 18.5 | 19.8 | 20.0 | 17.2 | 9.2 |
| S22 | dB | 15.0 | 14.6 | 14.5 | 14.7 | 16.2 | 19.7 | 16.4 |
| P1 | dBm | 18.0 | 18.3 | 18.5 | 18.1 | 17.8 | 17.0 | 16.0 |
| OIP3 | dBm | 35.0 | 34.5 | 34.0 | 30.5 | 32.0 | 31.0 | 29.5 |
| NF | dB | 2.6 | 2.9 | 2.8 | 3.0 | 3.0 | 3.1 | 3.2 |

Typical Performance (Vc = 4 V, Ic = 41mA, Ta = 25°C)

| Freq | MHz | 70 | 500 | 900 | 1900 | 2140 | 2450 | 3000 |
|------|-----|------|------|------|------|------|------|------|
| S21 | dB | 18.2 | 17.1 | 16.8 | 14.7 | 14.3 | 13.6 | 12.2 |
| S11 | dB | 17.1 | 21.3 | 19.8 | 20.5 | 20.1 | 16.7 | 9.0 |
| S22 | dB | 15.5 | 15.0 | 14.7 | 14.4 | 15.7 | 18.8 | 17.3 |
| P1 | dBm | 16.0 | 15.7 | 16.3 | 15.3 | 15.9 | 14.9 | 14.7 |
| OIP3 | dBm | 30.0 | 29.5 | 29.0 | 28.0 | 28.5 | 27.0 | 27.0 |
| NF | dB | 2.5 | 2.8 | 2.7 | 2.8 | 2.9 | 3.0 | 3.0 |

V-I Characteristics

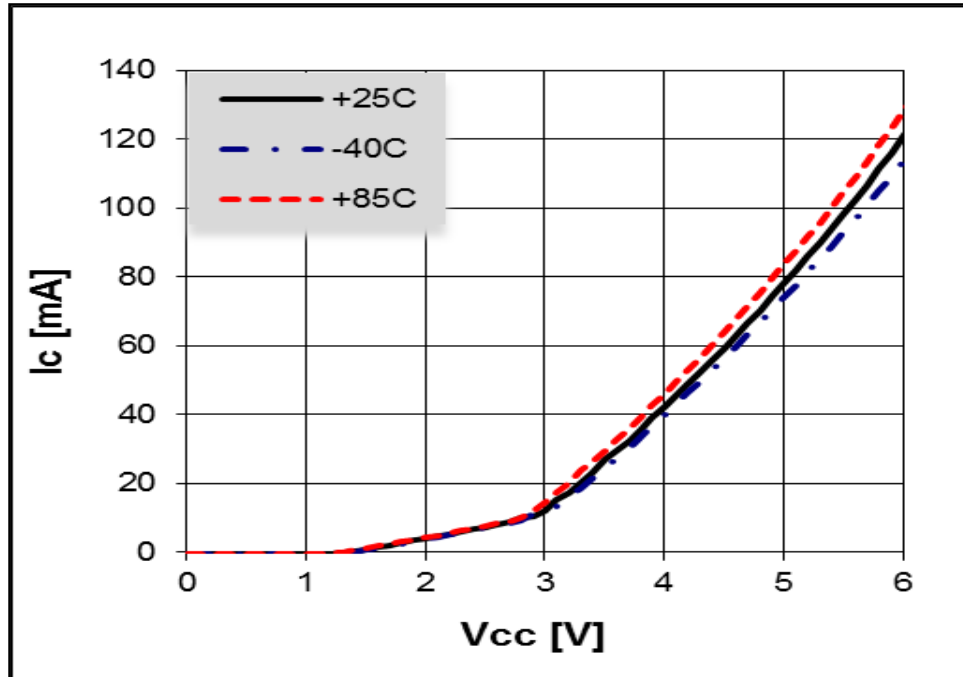

BeRex SOT89 Evaluation Board

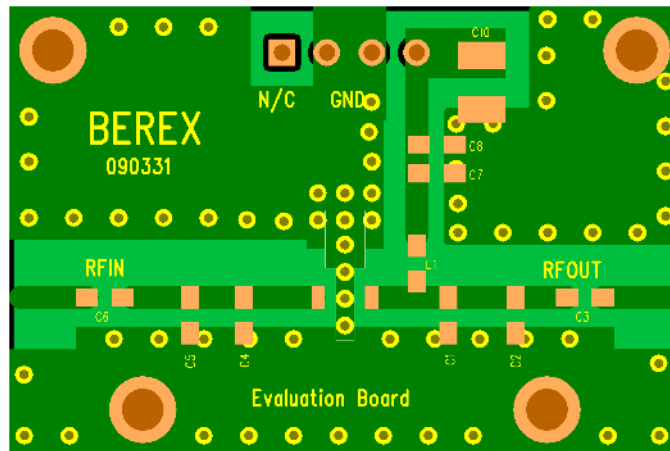

*Dielectric constant_ 4.2 *RF pattern width 52mil *31mil thick FR4 PCB

Typical Device Data

S-parameters (Vc=5V, Ic=77mA, T=25°C)

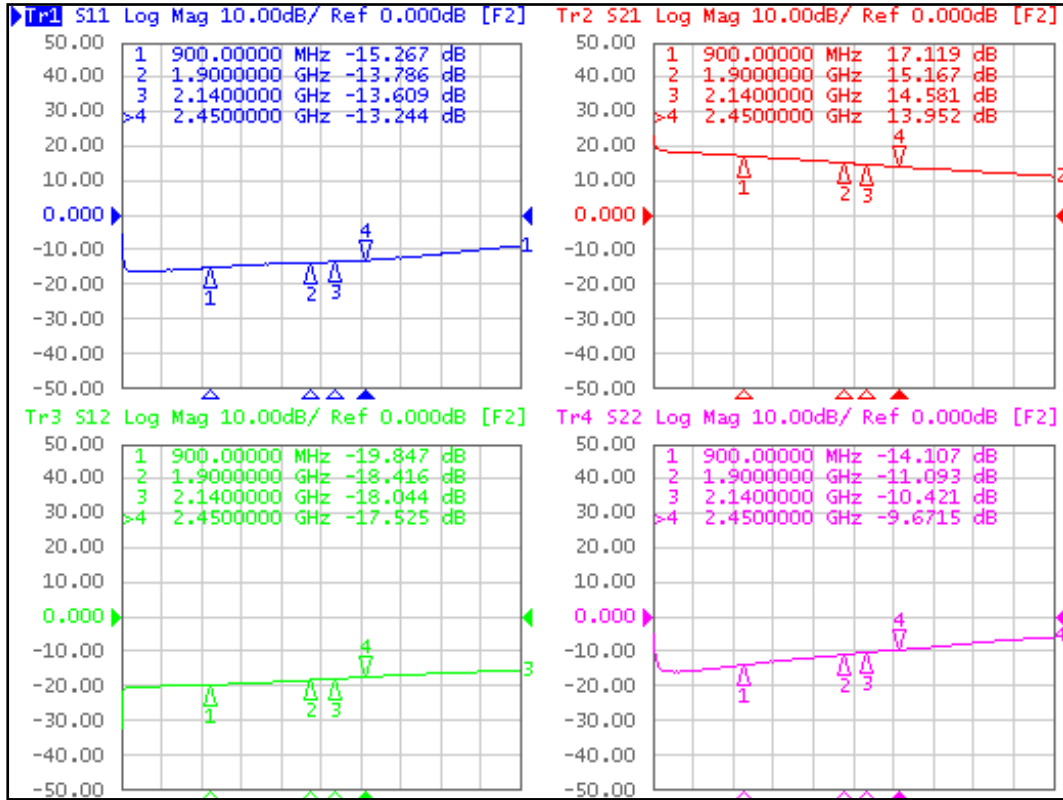

S-Parameter

(Vdevice = 5.0V, Icc = 77mA, T = 25 °C, calibrated to device leads)

| Freq [MHz] | S11 Mag | S11 Ang | S21 Mag | S21 Ang | S12 Mag | S12 Ang | S22 Mag | S22 Ang |
|------------|---------|----------|---------|----------|---------|----------|---------|---------|
| 100 | 0.435 | -93.440 | 7.978 | -161.916 | 0.087 | 37.728 | 0.265 | 168.924 |
| 500 | 0.143 | 166.000 | 7.808 | 118.617 | 0.097 | -30.484 | 0.145 | 161.418 |
| 1000 | 0.125 | 90.075 | 7.087 | 50.486 | 0.101 | -76.169 | 0.196 | 122.597 |
| 1500 | 0.121 | 35.562 | 6.289 | -12.945 | 0.109 | -120.275 | 0.208 | 69.413 |
| 2000 | 0.102 | 1.254 | 5.602 | -74.986 | 0.118 | -166.758 | 0.174 | 11.788 |
| 2500 | 0.150 | -1.546 | 4.918 | -137.711 | 0.125 | 143.157 | 0.089 | -40.867 |
| 3000 | 0.334 | -42.980 | 4.257 | 152.163 | 0.131 | 84.389 | 0.157 | 101.131 |
| 3500 | 0.521 | -144.348 | 1.518 | 123.642 | 0.055 | 64.369 | 0.549 | -41.536 |
| 4000 | 0.329 | 161.663 | 3.092 | 61.699 | 0.130 | 9.397 | 0.186 | 143.069 |

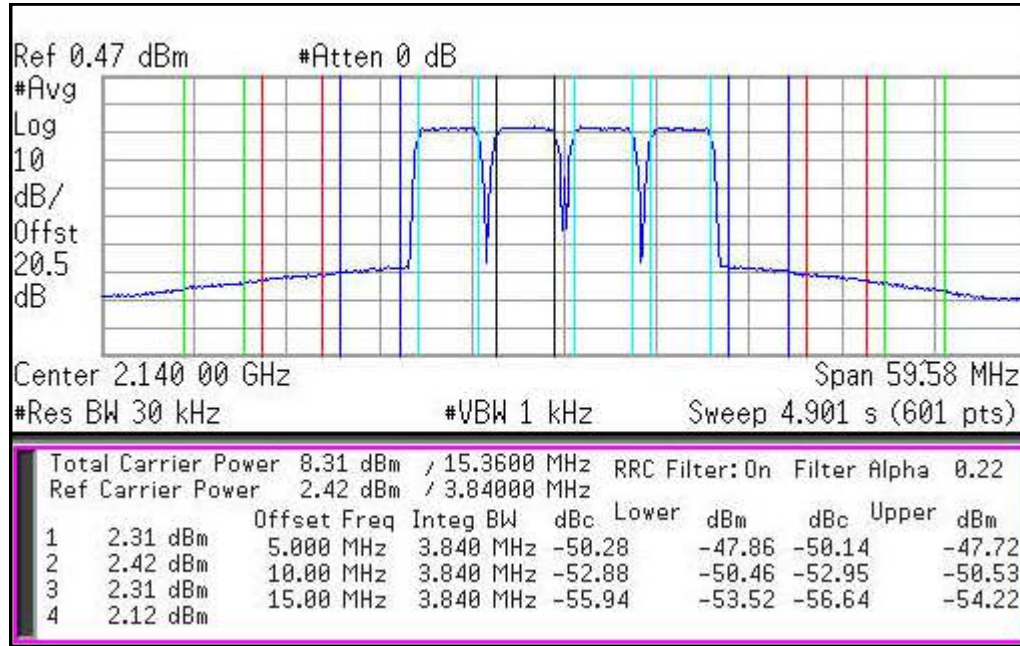
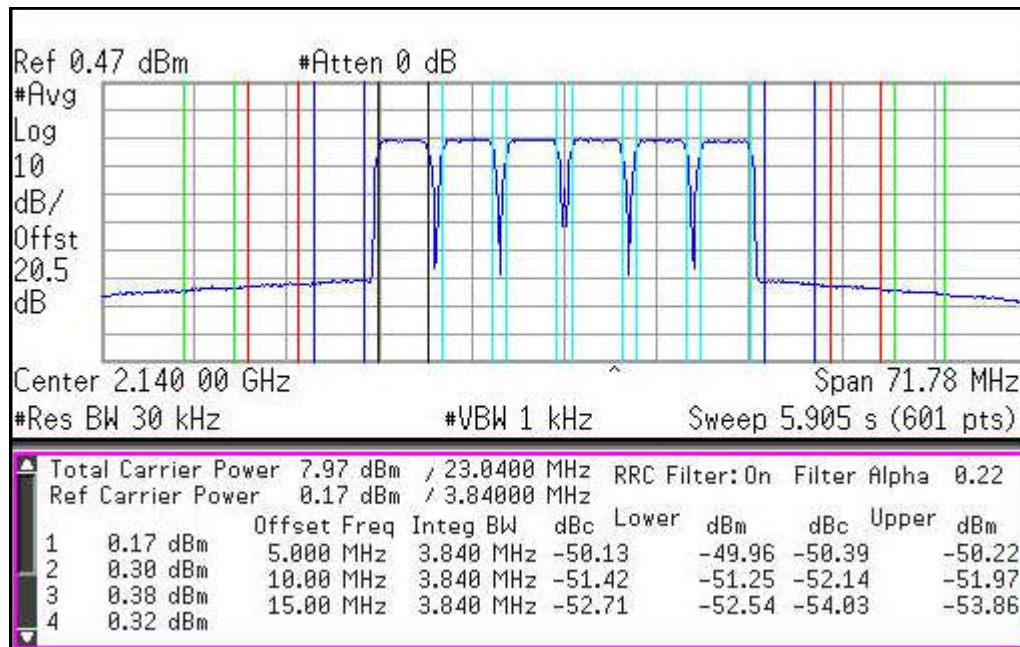
WCDMA 4FA 2140 -50dBc

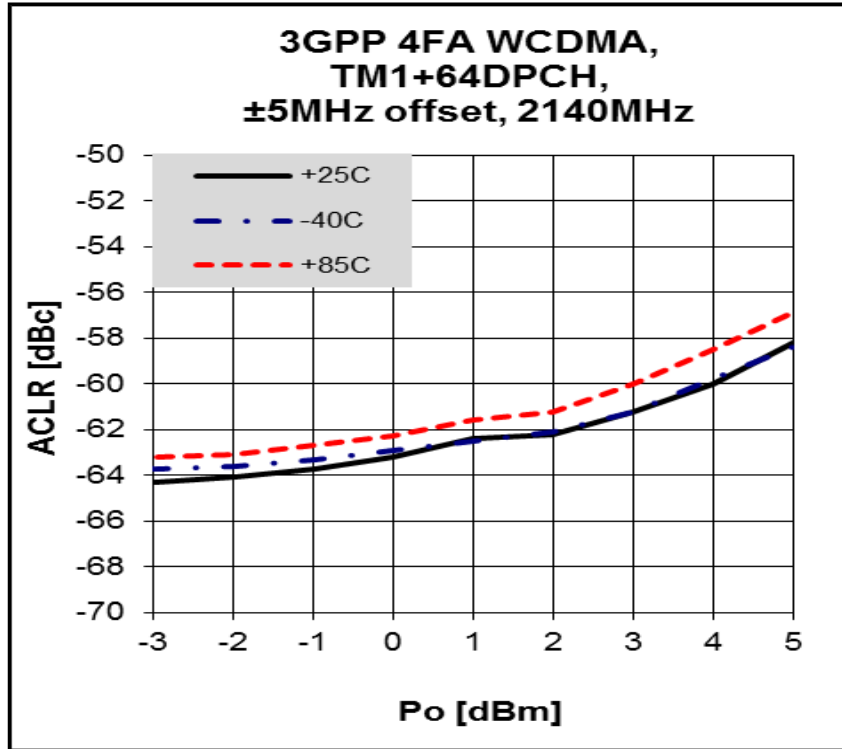
WCDMA 6FA 2140 -50dBc

ACLR

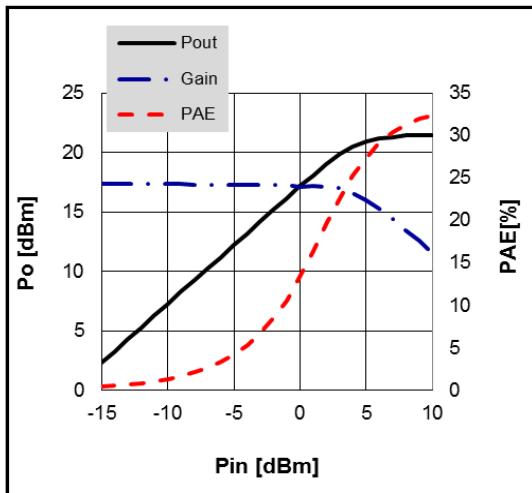
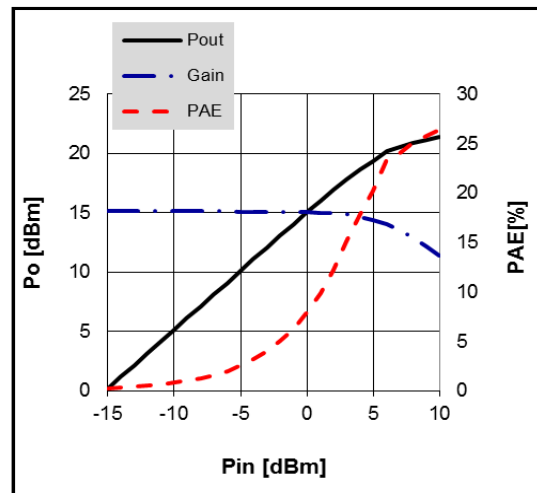
Typical Performance

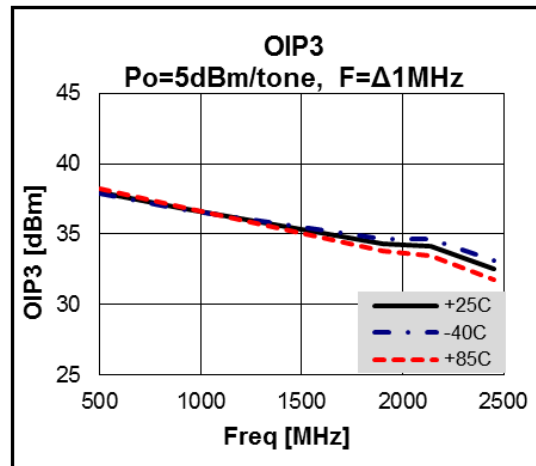
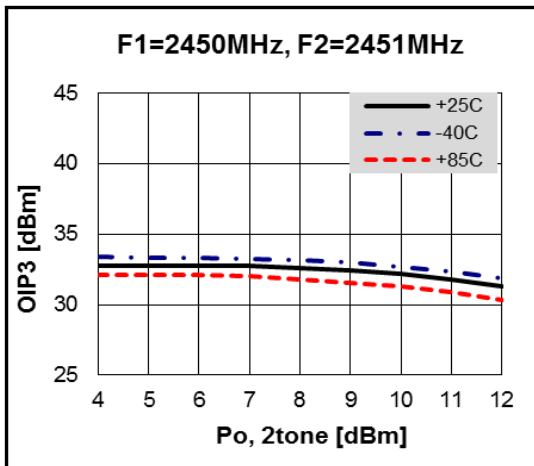
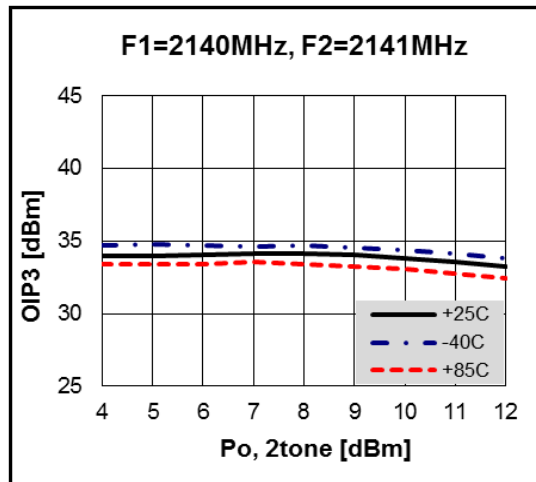
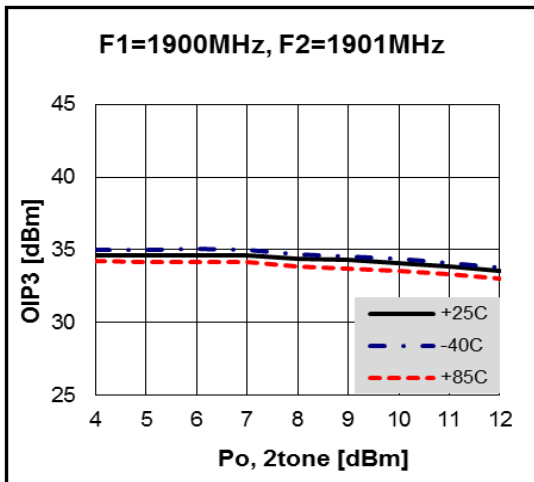
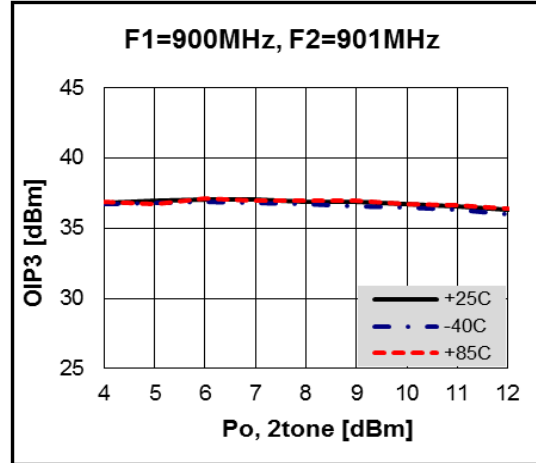
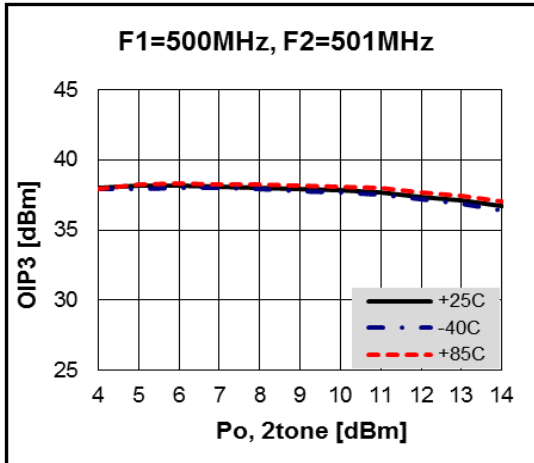
(Vc=5V, Ic=77mA, T=25°C)

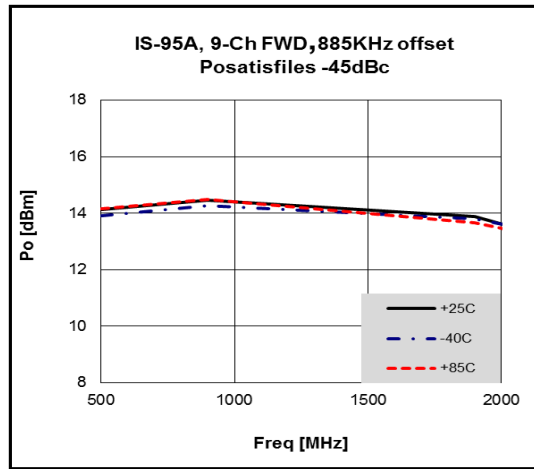
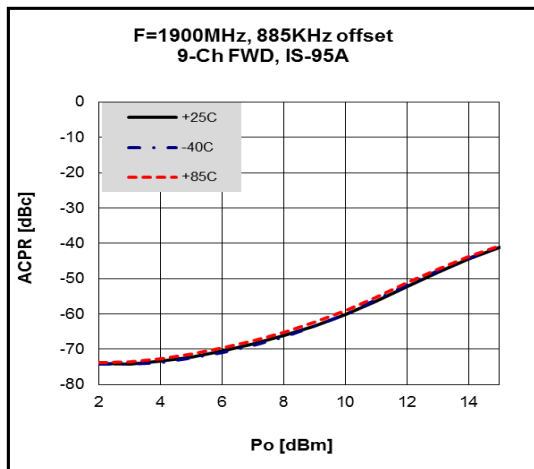
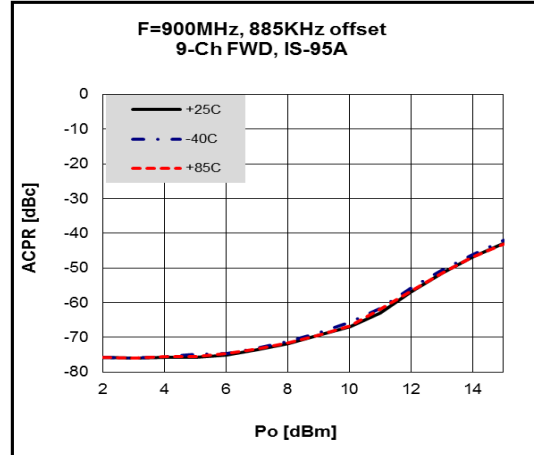
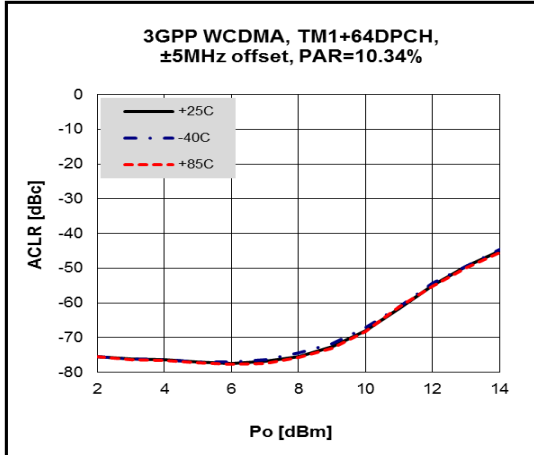
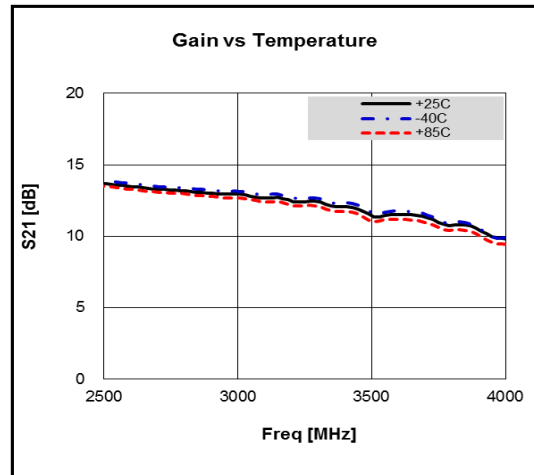
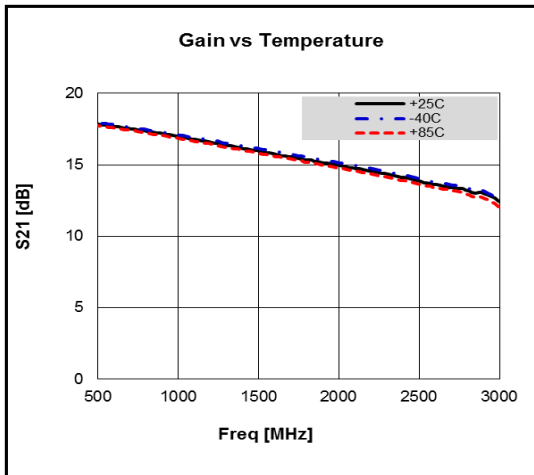
Pin-Pout-Gain

900MHz

1900 MHz

OIP3

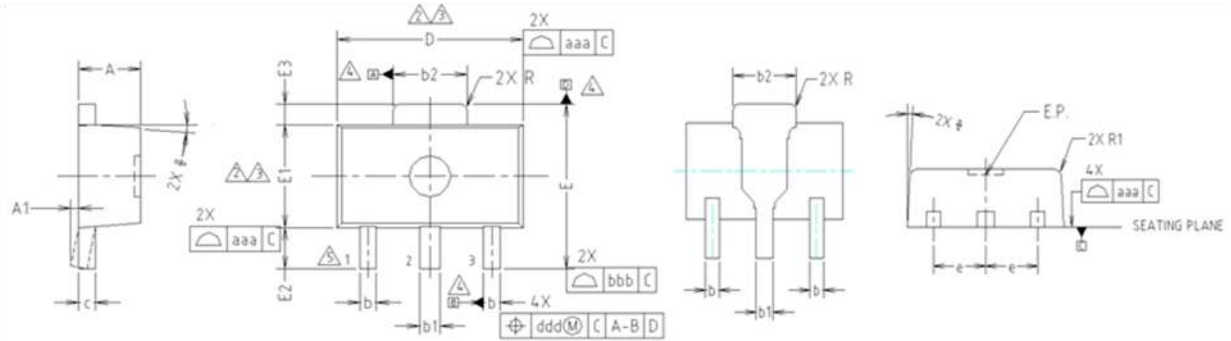
ACPR

Gain vs Temperature

Package Outline Dimension



- NOTE:**
 1. DIMENSIONS IN MILLIMETERS.
- ⚠ DIMENSION D DOES NOT INCLUDE MOLD FLASH, PROTRUSIONS OR GATE BURRS. MOLD FLASH, PROTRUSIONS OR GATE BURRS SHALL NOT EXCEED 0.5mm PER END. DIMENSION E1 DOES NOT INCLUDE INTERLEAD FLASH OR PROTRUSION. INTERLEAD FLASH OR PROTRUSION SHALL NOT EXCEED 0.5mm PER SIDE.
 - ⚠ DIMENSIONS D AND E1 ARE DETERMINED AT THE OUTMOST EXTREMES OF THE PLASTIC BODY EXCLUSIVE OF MOLD FLASH, TIE BAR BURRS, GATE BURRS AND INTERLEAD FLASH, BUT INCLUDING ANY MISMATCH BETWEEN THE TOP AND BOTTOM OF THE PLASTIC BODY.
 - ⚠ DATUMS A, B AND D TO BE DETERMINED 0.18mm FROM THE LEAD TIP.
 - ⚠ TERMINAL NUMBERS ARE SHOWN FOR REFERENCE ONLY.

| SYMBOL | MILLIMETERS | | | NOTE |
|--------|---------------------------------|---------|---------|------|
| | MINIMUM | NOMINAL | MAXIMUM | |
| A | 1.40 | 1.50 | 1.60 | |
| A1 | 0.00 | — | 0.10 | |
| b | 0.38 | 0.42 | 0.48 | |
| b1 | 0.48 | 0.52 | 0.58 | |
| b2 | 1.79 | 1.82 | 1.87 | |
| c | 0.40 | 0.42 | 0.46 | |
| D | 4.40 | 4.50 | 4.70 | 2,3 |
| E | 3.70 | 4.00 | 4.30 | |
| E1 | 2.40 | 2.50 | 2.70 | 2,3 |
| E2 | 0.80 | 1.00 | 1.20 | |
| E3 | 0.40 | 0.50 | 0.60 | |
| e | 1.50 TYP. | | | |
| φ | 4° TYP. | | | |
| R | 0.15 TYP. | | | |
| R1 | — | | | 0.20 |
| SYMBOL | TOLERANCES OF FORM AND POSITION | | NOTE | |
| aaa | 0.15 | | | |
| bbb | 0.20 | | | |
| ccc | 0.10 | | | |
| ddd | 0.10 | | | |

Suggested PCB Land Pattern and PAD Layout

PCB Land Pattern

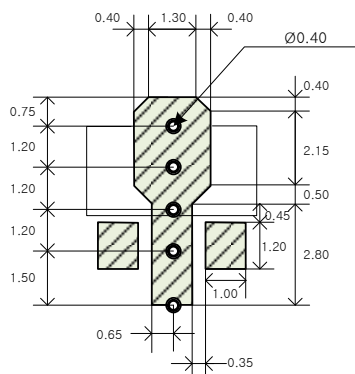

Note : All dimension _ millimeters

PCB lay out _ on BeRex website

PCB Mounting

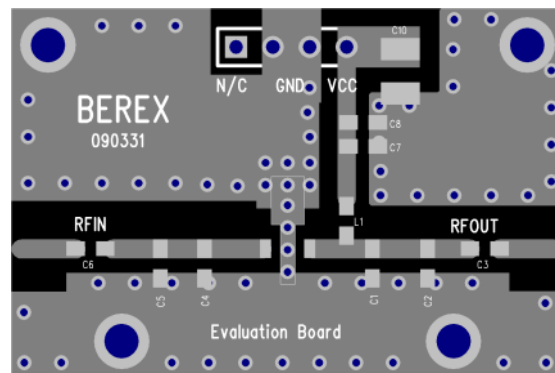

Package Marking

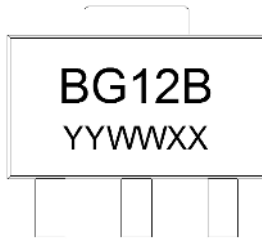

Pin 1

YY = Year, WW = Working Week,
XX = Wafer No.

Tape & Reel

SOT89

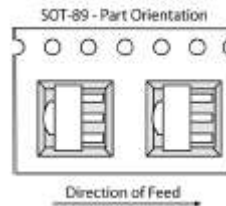

Packaging information:

Tape Width (mm): 12
Reel Size (inches): 7
Device Cavity Pitch (mm): 8
Devices Per Reel: 1000

Lead plating finish

100% Tin Matte finish

(All BeRex products undergoes a 1 hour, 150 degree C, Anneal bake to eliminate thin whisker growth concerns.)

MSL / ESD Rating

| | |
|--------------------|--|
| ESD Rating: | Class 1C |
| Value: | Passes <2000V |
| Test: | Human Body Model (HBM) |
| Standard: | JEDEC Standard JESD22-A114 |
| | |
| MSL Rating: | Level 1 at +260°C convection reflow |
| Standard: | JEDEC Standard J-STD-020 |



Proper ESD procedures should be followed when handling this device.

RoHS Compliance

This part is compliant with Restrictions on the Use of Certain Hazardous Substances in Electrical and Electronic Equipment (RoHS) Directive 2011/65/EU as amended by Directive 2015/863/EU.

This product also is compliant with a concentration of the Substances of Very High Concern (SVHC) candidate list which are contained in a quantity of less than 0.1%(w/w) in each components of a product and/or its packaging placed on the European Community market by the BeRex and Suppliers.

NATO CAGE code:

| | | | | |
|---|---|---|---|---|
| 2 | N | 9 | 6 | F |
|---|---|---|---|---|