



## 9322/DM9322 Quad 2-Line to 1-Line Data Selectors/Multiplexers

### General Description

These data selectors/multiplexers contain inverters and drivers to supply full on-chip data selection to the four output gates. A separate strobe input is provided. A 4-bit word is selected from one of two sources and is routed to the four outputs. True data is presented at the outputs.

### Features

- Pin-for-pin with popular DM54157/74157
- Buffered inputs and outputs

### Applications

- Expand any data input point
- Multiplex dual-data buses
- Generate four functions of two variables (one variable is common)
- Source programmable counters
- Alternate Military/Aerospace device (9322) is available. Contact a National Semiconductor Sales Office/Distributor for specifications.

### Connection Diagram

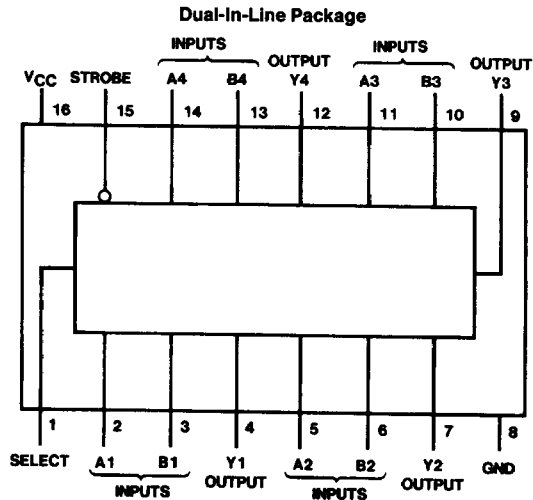

Order Number 9322DMQB, 9322FMQB, DM9322J,  
DM9322W or DM8322N  
See NS Package Number J16A, N16E or W16A

TL/F/6608-1

### Function Table

Strobe	Inputs			Output Y
	Select	A	B	
H	X	X	X	L
L	L	L	X	L
L	L	H	X	L
L	H	X	L	L
L	H	X	H	H

H = High Level, L = Low Level, X = Don't Care.

## Absolute Maximum Ratings (Note)

If Military/Aerospace specified devices are required, please contact the National Semiconductor Sales Office/Distributors for availability and specifications.

Supply Voltage	7V
Input Voltage	5.5V
Operating Free Air Temperature Range	
Military	-55°C to +125°C
Commercial	0°C to +70°C
Storage Temperature Range	-65°C to +150°C

Note: The "Absolute Maximum Ratings" are those values beyond which the safety of the device cannot be guaranteed. The device should not be operated at these limits. The parametric values defined in the "Electrical Characteristics" table are not guaranteed at the absolute maximum ratings. The "Recommended Operating Conditions" table will define the conditions for actual device operation.

## Recommended Operating Conditions

Symbol	Parameter	Military			Commercial			Units
		Min	Nom	Max	Min	Nom	Max	
V <sub>CC</sub>	Supply Voltage	4.5	5	5.5	4.75	5	5.25	V
V <sub>IH</sub>	High Level Input Voltage	2			2			V
V <sub>IL</sub>	Low Level Input Voltage			0.8			0.8	V
I <sub>OH</sub>	High Level Output Current			-0.8			-0.8	mA
I <sub>OL</sub>	Low Level Output Current			16			16	mA
T <sub>A</sub>	Free Air Operating Temperature	-55		125	0		70	°C

## Electrical Characteristics over recommended operating free air temperature range (unless otherwise noted)

Symbol	Parameter	Conditions	Min	Typ (Note 1)	Max	Units
V <sub>I</sub>	Input Clamp Voltage	V <sub>CC</sub> = Min, I <sub>I</sub> = -12 mA			-1.5	V
V <sub>OH</sub>	High Level Output Voltage	V <sub>CC</sub> = Min, I <sub>OH</sub> = Max V <sub>IL</sub> = Max, V <sub>IH</sub> = Min	2.4	3.4		V
V <sub>OL</sub>	Low Level Output Voltage	V <sub>CC</sub> = Min, I <sub>OL</sub> = Max V <sub>IH</sub> = Min, V <sub>IL</sub> = Max		0.2	0.4	V
I <sub>I</sub>	Input Current @ Max Input Voltage	V <sub>CC</sub> = Max, V <sub>I</sub> = 5.5V			1	mA
I <sub>IH</sub>	High Level Input Current	V <sub>CC</sub> = Max, V <sub>I</sub> = 2.4V			40	μA
I <sub>IL</sub>	Low Level Input Current	V <sub>CC</sub> = Max, V <sub>I</sub> = 0.4V			-1.6	mA
I <sub>OS</sub>	Short Circuit Output Current	V <sub>CC</sub> = Max (Note 2)	MIL -20		-55	mA
			COM -18		-55	
I <sub>CC</sub>	Supply Current	V <sub>CC</sub> = Max (Note 3)		30	48	mA

Note 1: All typicals are at V<sub>CC</sub> = 5V, T<sub>A</sub> = 25°C.

Note 2: Not more than one output should be shorted at a time.

Note 3: I<sub>CC</sub> is measured with 4.5V applied to all inputs and all outputs open.

## Switching Characteristics at $V_{CC} = 5V$ and $T_A = 25^\circ C$ (See Section 1 for Test Waveforms and Output Load)

Symbol	Parameter	From (Input) To (Output)	$R_L = 400\Omega, C_L = 15\text{ pF}$		Units
			Min	Max	
$t_{PLH}$	Propagation Delay Time Low to High Level Output	Data to Output		14	ns
$t_{PHL}$	Propagation Delay Time High to Low Level Output	Data to Output		14	ns
$t_{PLH}$	Propagation Delay Time Low to High Level Output	Strobe to Output		20	ns
$t_{PHL}$	Propagation Delay Time High to Low Level Output	Strobe to Output		21	ns
$t_{PLH}$	Propagation Delay Time Low to High Level Output	Select to Output		23	ns
$t_{PHL}$	Propagation Delay Time High to Low Level Output	Select to Output		27	ns

## Logic Diagram

9322

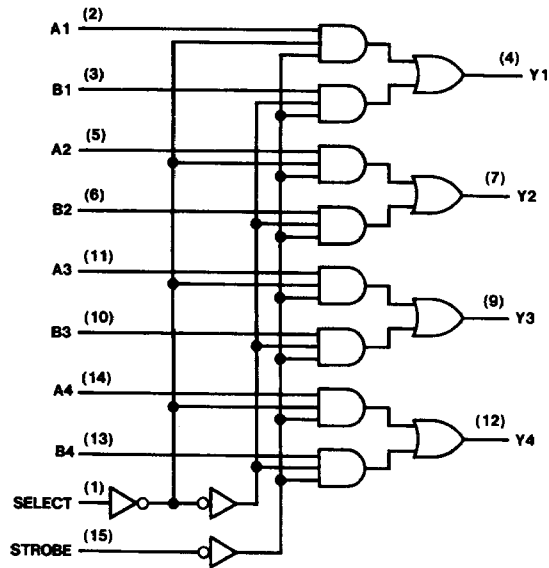

TL/F/6608-2