

DO NOT
SCALE FROM
THIS PRINT

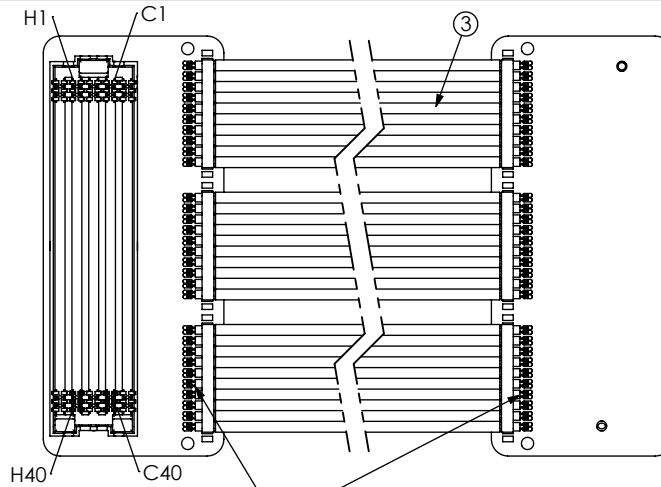

ALL CABLE TERMINATIONS
TO BE POTTED WITH UV EPOXY
(SEE SHT 2)

Pb THIS PRODUCT MANUFACTURED
WITH LEAD-FREE PROCESSING

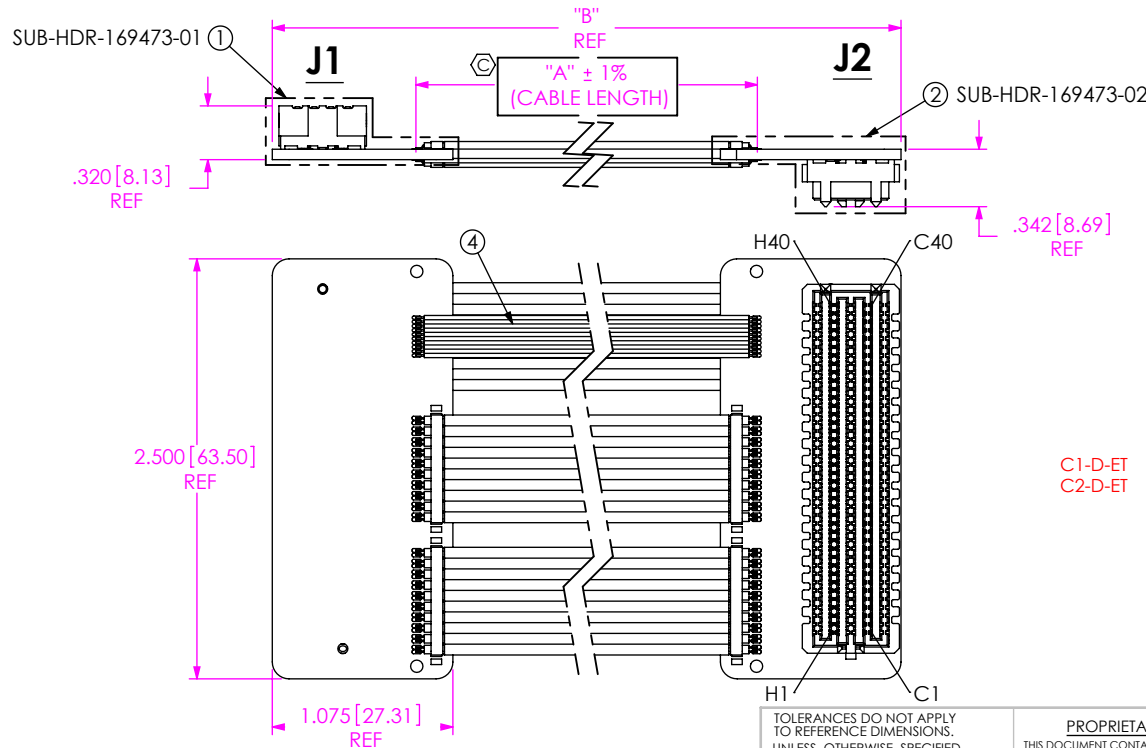
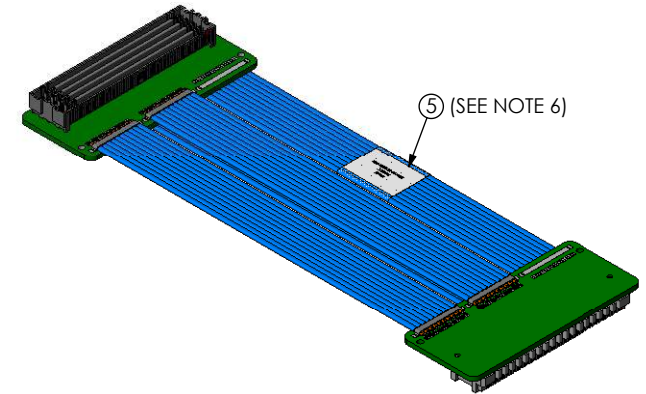

* NON STANDARD LENGTH IS NOT STOCKED

PART #	"A"	"B"
HDR-169473-01	10.10 [256.5]	11.81 [300.0]
HDR-169473-02	19.94 [506.6]	21.65 [550.0]
HDR-169473-04*	39.63 [1,006.6]	41.34 [1,050.0]

NOTES:

- CABLE CONFIGURATIONS IS NOT STANDARD.
- ⊗ REPRESENTS A CRITICAL DIMENSION.
- PARTS TO BE PROCESSED PER SAMTEC BOUNDARY DOCUMENT GUIDELINES.
- ALL ASSEMBLIES TO BE 100% ELECTRICALLY TESTED.
- ALL ASSEMBLIES TO BE 100% HI-POT TESTED AT 300V.
- ITEM 5 TO BE CENTERED ON ITEM 3 AS SHOWN. ITEM 5 TO CONTAIN:
LINE 1 - PART NUMBER "HDR-XXXXXX-XX"
LINE 2 - SHOP ORDER NUMBER "XXXXXX"
LINE 3 - DATE CODE "XXXXX".
- NUMERIC REVISION PRODUCT WILL HAVE ADDITIONAL LABEL INDICATING "RELEASE FOR LIMITED PRODUCTION".
- FOR PROCESSING INFORMATION ON SUB ASSEMBLIES, REFERENCE SUB-HDR-169473-XX TRAVELER.XLS.
- FOR SUB-ASSEMBLY AND FINISHED GOOD PACKAGING REQUIREMENTS, REFERENCE PACKAGING STANDARD CO-HD-WI-3033-M.
- PANEL PCB-103811-HDR-XX YIELDS (04) PCB-103811-HDR-01 AND (04) PCB-103811-HDR-02 BOARDS.

C1-D-ET
C2-D-ET

ITEM NO.	PART NUMBER	DESCRIPTION	QUANTITY	MATERIAL
1	SUB-HDR-169473-01	SUB ASSEMBLY	1	SUB ASSEMBLY
2	SUB-HDR-169473-02	SUB ASSEMBLY	1	SUB ASSEMBLY
3	SUB-TTF-32100-10-01-XX.XX	TWNA X CABLE	5	SUB ASSEMBLY
4	SUB-SPL-30-10-02-XX.XX	NON SHIELDED CABLE	1	SUB ASSEMBLY
5	HDRL-11	LA BEL	1	SELF LAMINATING VINYL

TOLERANCES DO NOT APPLY TO REFERENCE DIMENSIONS, UNLESS OTHERWISE SPECIFIED. DIMENSIONS ARE IN INCHES.
TOLERANCES ARE:
DECIMALS .XX: ±.01 [.3]
.XXX: ±.005 [.13]
.XXXX: ±.0020 [.051]

PROPRIETARY NOTE

THIS DOCUMENT CONTAINS INFORMATION CONFIDENTIAL AND PROPRIETARY TO SAMTEC, INC. AND SHALL NOT BE REPRODUCED OR TRANSFERRED TO OTHER DOCUMENTS OR DISCLOSED TO OTHERS OR USED FOR ANY PURPOSE OTHER THAN THAT WHICH IT WAS OBTAINED WITHOUT THE EXPRESSED WRITTEN CONSENT OF SAMTEC, INC.



520 PARK EAST BLVD, NEW ALBANY, IN 47150
PHONE: 812-944-6733 FAX: 812-948-5047
e-Mail: info@SAMTEC.com code 53322

DO NOT SCALE DRAWING

SHEET SCALE: 7:8

DESCRIPTION: CUSTOM HDR CABLE ASSEMBLY

DWG. NO. HDR-169473-XX

BY: ANDREW C 05/02/2012 SHEET 1 OF 3

Pb THIS PRODUCT MANUFACTURED WITH LEAD-FREE PROCESSING

Pb THIS PRODUCT MANUFACTURED WITH LEAD-FREE PROCESSING

**SUB SETUP OPTION:
HDR-SUB-02**

**SUB SETUP OPTION:
HDR-SUB-02**

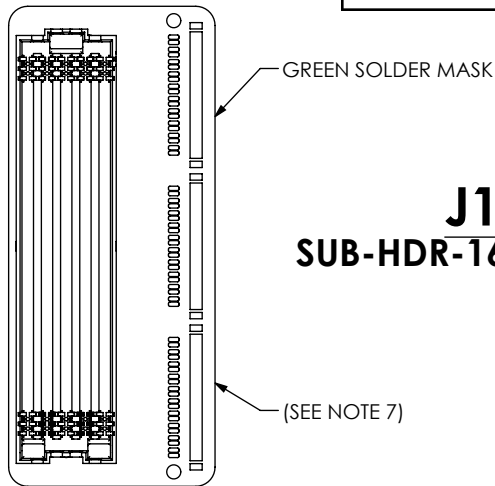

**J1
SUB-HDR-169473-01**

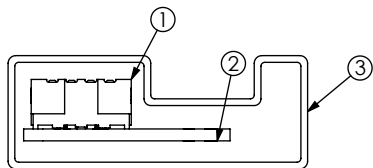

PACKAGING TUBE TO BE SPECIFIED AT FIRST PRODUCTION RUN.

B

SUB-HDR-169473-01 BOM

ITEM NO.	PART NUMBER	QUANTITY	MATERIAL
1	ASP-134603-01	1	TERMINAL
2	PCB-103811-HDR-01	1	PCB
3	PT-1-24-01-81	0.04348	TUBE
4	TP-28	0.08696	PLUG

(SEE NOTE 7)

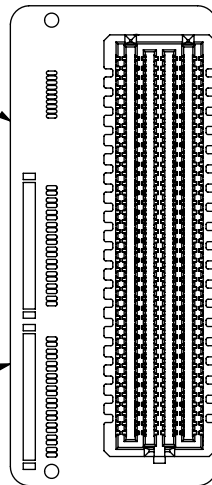

**J2
SUB-HDR-169473-02**

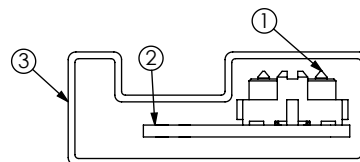

PACKAGING TUBE TO BE SPECIFIED AT FIRST PRODUCTION RUN.

B

SUB-HDR-169473-02 BOM

ITEM NO.	PART NUMBER	QUANTITY	MATERIAL
1	ASP-134604-01	1	TERMINAL
2	PCB-103811-HDR-02	1	PCB
3	PT-1-24-01-81	0.04348	TUBE
4	TP-28	0.08696	PLUG

TABLE 3 NET COUNT		
TYPE	NETS	POINTS
POINT TO POINT	89	178
GND	1	122
POWER - 12POV	1	4
POWER - 3P3V	1	8
POWER - 3P3VAUX	1	2
POWER - VADJ	1	4
POWER - VREF A M2C	1	2

CRITICAL DIMENSION INSPECTION INSTRUCTION TABLE	
ASSEMBLY OPERATION	IN-PROCESS INSPECTION
PREP CABLE	C3
E-TEST	C1, C2

ALL CABLE TERMINATIONS TO BE POTTED WITH UV EPOXY



PROPRIETARY NOTE

THIS DOCUMENT CONTAINS INFORMATION CONFIDENTIAL AND PROPRIETARY TO SAMTEC, INC. AND SHALL NOT BE REPRODUCED OR TRANSFERRED TO OTHER DOCUMENTS OR DISCLOSED TO OTHERS OR USED FOR ANY PURPOSE OTHER THAN THAT WHICH IT WAS OBTAINED WITHOUT THE EXPRESSED WRITTEN CONSENT OF SAMTEC, INC.

DO NOT SCALE DRAWING

SHEET SCALE: 1:1



520 PARK EAST BLVD, NEW ALBANY, IN 47150
PHONE: 812-944-6733 FAX: 812-948-5047
e-Mail info@SAMTEC.com code 53322

DESCRIPTION:
CUSTOM HDR CABLE ASSEMBLY

DWG. NO.
HDR-169473-XX

BY: ANDREW C 05/02/2012 SHEET 2 OF 3

TABLE 2

SIGNAL MAPPING										
	A	B	C	D	E	F	G	H	J	K
1	NO CONNECT	NO CONNECT	GND	PG C2M	NO CONNECT	NO CONNECT	GND	VREF A M2C	NO CONNECT	NO CONNECT
2	NO CONNECT	NO CONNECT	DP0_C2M_P	GND	NO CONNECT	NO CONNECT	CLK1_M2C_N	PRSNT_M2C_L	NO CONNECT	NO CONNECT
3	NO CONNECT	NO CONNECT	DP0_C2M_N	GND	NO CONNECT	NO CONNECT	CLK1_M2C_P	GND	NO CONNECT	NO CONNECT
4	NO CONNECT	NO CONNECT	GND	GBTCLK0_M2C_P	NO CONNECT	NO CONNECT	GND	CLK0_M2C_N	NO CONNECT	NO CONNECT
5	NO CONNECT	NO CONNECT	GND	GBTCLK0_M2C_N	NO CONNECT	NO CONNECT	GND	CLK0_M2C_P	NO CONNECT	NO CONNECT
6	NO CONNECT	NO CONNECT	DP0_M2C_P	GND	NO CONNECT	NO CONNECT	LA00_P_CC	GND	NO CONNECT	NO CONNECT
7	NO CONNECT	NO CONNECT	DP0_M2C_N	GND	NO CONNECT	NO CONNECT	LA00_N_CC	LA02_P	NO CONNECT	NO CONNECT
8	NO CONNECT	NO CONNECT	GND	LA01_P_CC	NO CONNECT	NO CONNECT	GND	LA02_N	NO CONNECT	NO CONNECT
9	NO CONNECT	NO CONNECT	GND	LA01_N_CC	NO CONNECT	NO CONNECT	LA03_P	GND	NO CONNECT	NO CONNECT
10	NO CONNECT	NO CONNECT	LA06_P	GND	NO CONNECT	NO CONNECT	LA03_N	LA04_P	NO CONNECT	NO CONNECT
11	NO CONNECT	NO CONNECT	LA06_N	LA05_P	NO CONNECT	NO CONNECT	GND	LA04_N	NO CONNECT	NO CONNECT
12	NO CONNECT	NO CONNECT	GND	LA05_N	NO CONNECT	NO CONNECT	LA08_P	GND	NO CONNECT	NO CONNECT
13	NO CONNECT	NO CONNECT	GND	GND	NO CONNECT	NO CONNECT	LA08_N	LA07_P	NO CONNECT	NO CONNECT
14	NO CONNECT	NO CONNECT	LA10_P	LA09_P	NO CONNECT	NO CONNECT	GND	LA07_N	NO CONNECT	NO CONNECT
15	NO CONNECT	NO CONNECT	LA10_N	LA09_N	NO CONNECT	NO CONNECT	LA12_P	GND	NO CONNECT	NO CONNECT
16	NO CONNECT	NO CONNECT	GND	GND	NO CONNECT	NO CONNECT	LA12_N	LA11_P	NO CONNECT	NO CONNECT
17	NO CONNECT	NO CONNECT	GND	LA13_P	NO CONNECT	NO CONNECT	GND	LA11_N	NO CONNECT	NO CONNECT
18	NO CONNECT	NO CONNECT	LA14_P	LA13_N	NO CONNECT	NO CONNECT	LA16_P	GND	NO CONNECT	NO CONNECT
19	NO CONNECT	NO CONNECT	LA14_N	GND	NO CONNECT	NO CONNECT	LA16_N	LA15_P	NO CONNECT	NO CONNECT
20	NO CONNECT	NO CONNECT	GND	LA17_P_CC	NO CONNECT	NO CONNECT	GND	LA15_N	NO CONNECT	NO CONNECT
21	NO CONNECT	NO CONNECT	GND	LA17_N_CC	NO CONNECT	NO CONNECT	LA20_P	GND	NO CONNECT	NO CONNECT
22	NO CONNECT	NO CONNECT	LA18_P_CC	GND	NO CONNECT	NO CONNECT	LA20_N	LA19P	NO CONNECT	NO CONNECT
23	NO CONNECT	NO CONNECT	LA18_N_CC	LA23_P	NO CONNECT	NO CONNECT	GND	LA19_N	NO CONNECT	NO CONNECT
24	NO CONNECT	NO CONNECT	GND	LA23_N	NO CONNECT	NO CONNECT	LA22_P	GND	NO CONNECT	NO CONNECT
25	NO CONNECT	NO CONNECT	GND	GND	NO CONNECT	NO CONNECT	LA22_N	LA21_P	NO CONNECT	NO CONNECT
26	NO CONNECT	NO CONNECT	LA27_P	LA26_P	NO CONNECT	NO CONNECT	GND	LA21_N	NO CONNECT	NO CONNECT
27	NO CONNECT	NO CONNECT	LA27_N	LA26_N	NO CONNECT	NO CONNECT	LA25_P	GND	NO CONNECT	NO CONNECT
28	NO CONNECT	NO CONNECT	GND	GND	NO CONNECT	NO CONNECT	LA25_N	LA24_P	NO CONNECT	NO CONNECT
29	NO CONNECT	NO CONNECT	GND	TCK	NO CONNECT	NO CONNECT	GND	LA24_N	NO CONNECT	NO CONNECT
30	NO CONNECT	NO CONNECT	SCL	TDI	NO CONNECT	NO CONNECT	LA29_P	GND	NO CONNECT	NO CONNECT
31	NO CONNECT	NO CONNECT	SDA	TDO	NO CONNECT	NO CONNECT	LA29_N	LA28_P	NO CONNECT	NO CONNECT
32	NO CONNECT	NO CONNECT	GND	3P3VAUX	NO CONNECT	NO CONNECT	GND	LA28_N	NO CONNECT	NO CONNECT
33	NO CONNECT	NO CONNECT	GND	TMS	NO CONNECT	NO CONNECT	LA31_P	GND	NO CONNECT	NO CONNECT
34	NO CONNECT	NO CONNECT	GA0	TRST_L	NO CONNECT	NO CONNECT	LA31_N	LA30_P	NO CONNECT	NO CONNECT
35	NO CONNECT	NO CONNECT	12POV	GA1	NO CONNECT	NO CONNECT	GND	LA30_N	NO CONNECT	NO CONNECT
36	NO CONNECT	NO CONNECT	GND	3P3V	NO CONNECT	NO CONNECT	LA33_P	GND	NO CONNECT	NO CONNECT
37	NO CONNECT	NO CONNECT	12POV	GND	NO CONNECT	NO CONNECT	LA33_N	LA32_P	NO CONNECT	NO CONNECT
38	NO CONNECT	NO CONNECT	GND	3P3V	NO CONNECT	NO CONNECT	GND	LA32_N	NO CONNECT	NO CONNECT
39	NO CONNECT	NO CONNECT	3P3V	GND	NO CONNECT	NO CONNECT	VADJ	GND	NO CONNECT	NO CONNECT
40	NO CONNECT	NO CONNECT	GND	3P3V	NO CONNECT	NO CONNECT	GND	VADJ	NO CONNECT	NO CONNECT

PROPRIETARY NOTE
 THIS DOCUMENT CONTAINS INFORMATION
 CONFIDENTIAL AND PROPRIETARY TO
 SAMTEC, INC. AND SHALL NOT BE REPRODUCED
 OR TRANSFERRED TO OTHER DOCUMENTS OR
 DISCLOSED TO OTHERS OR USED FOR ANY
 PURPOSE OTHER THAN THAT WHICH IT WAS
 OBTAINED WITHOUT THE EXPRESSED WRITTEN
 CONSENT OF SAMTEC, INC.



520 PARK EAST BLVD, NEW ALBANY, IN 47150
 PHONE: 812-944-6733 FAX: 812-948-5047
 e-Mail: info@SAMTEC.com code 53322

DO NOT SCALE DRAWING

DESCRIPTION:
 CUSTOM HDR CABLE ASSEMBLY

DWG. NO.
 HDR-169473-XX

SHEET SCALE: 1:1

BY: ANDREW C 05/02/2012 SHEET 3 OF 3