

8 7 6 5 4 3 2 1

NOTES:

1. MOUNTING: Mounts in a $\phi .250 \pm .002$ [$\phi 6.35\text{mm} \pm .05$] panel hole on .375 [9.5mm] centers. Panel thickness .031 [.8 mm] to .250 [6.35mm]. Panel hole should be deburred, but not chamfered.
2. ASSEMBLY: Insert lens through panel hole, (for thin panels less than .188 [4.75mm] thick, slide SPC 125 spacer on back of lens), and insert LED into lens.
3. MATERIAL: Polycarbonate, UL 94-V2
4. U.S. & Foreign Pat. Issued & Pend.

REVISIONS				
ECN#	REV.	DESCRIPTION	DATE	INITIALS
	001	REVISED PER EC R111009AZ01	4-23-10	SMU

RETAINERS
(ORDER SEPARATELY)

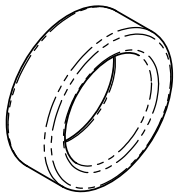

SPC 125

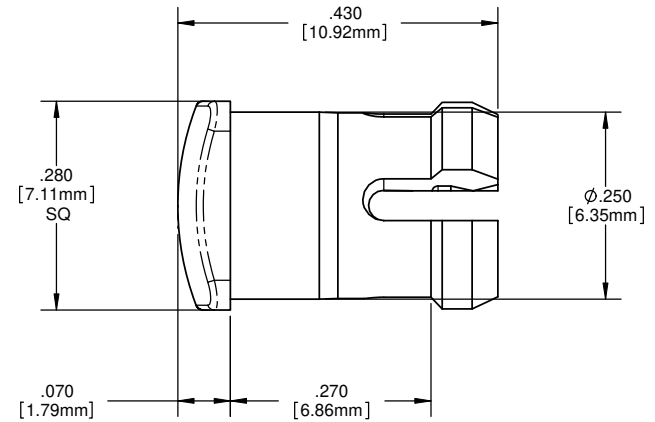
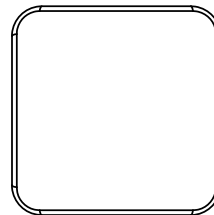
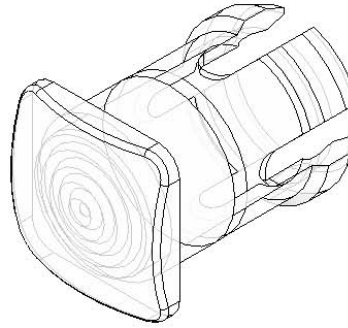

ORDERING CODE : SQB 400 XXX

MODEL

LENS COLOR	
RTP	RED TRANSPARENT
ATP	AMBER TRANSPARENT
GTP	GREEN TRANSPARENT
BTP	BLUE TRANSPARENT
YTP	YELLOW TRANSPARENT
CTP	CLEAR TRANSPARENT

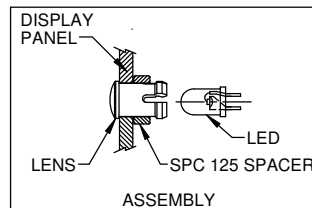

<small>UNLESS OTHERWISE SPECIFIED DIMENSIONS ARE IN INCHES</small> ANGLES DECIMALS $\pm 1^\circ$.X $\pm .020$ FINISH .XXX $\pm .010$.XXX $\pm .005$ BREAK ALL CORNERS AND SHARP EDGES 90° MIN	MATERIAL POLYCARBONATE, UL 94-V2	VISUAL COMMUNICATIONS COMPANY, INC. 190 Bosstick Boulevard, Suite 101 San Marcos, CA 92069 USA Phone (760) 560-1300 Fax (760) 560-1301 email vccsales@vccite.com
	FINISH SEE NOTES	TITLE: 5MM SQUARE LOW PROFILE FRESNEL LENS
THIRD ANGLE PROJECTION <small>THE INFORMATION CONTAINED IN THIS DRAWING IS THE SOLE PROPERTY OF VISUAL COMMUNICATIONS COMPANY, INC. AND IS REPRODUCED IN PART OR AS A WHOLE WITHOUT THE WRITTEN CONSENT OF VISUAL COMMUNICATIONS COMPANY, INC.</small>	APPROVAL DRAWN: SMU 4-23-10 CHECKED: DZ 4-23-10 DO NOT SCALE DRAWING	DATE DATE DATE
SIZE DWG. NO. B SQB 400 XXX		REV 001
SCALE: 1:1		SHEET 1 OF 1

8 7 6 5 4 3 2 1