

7-16
4.3-10

Adaptor
7-16 Plug – 4.3-10 Jack

60S164-K00N1

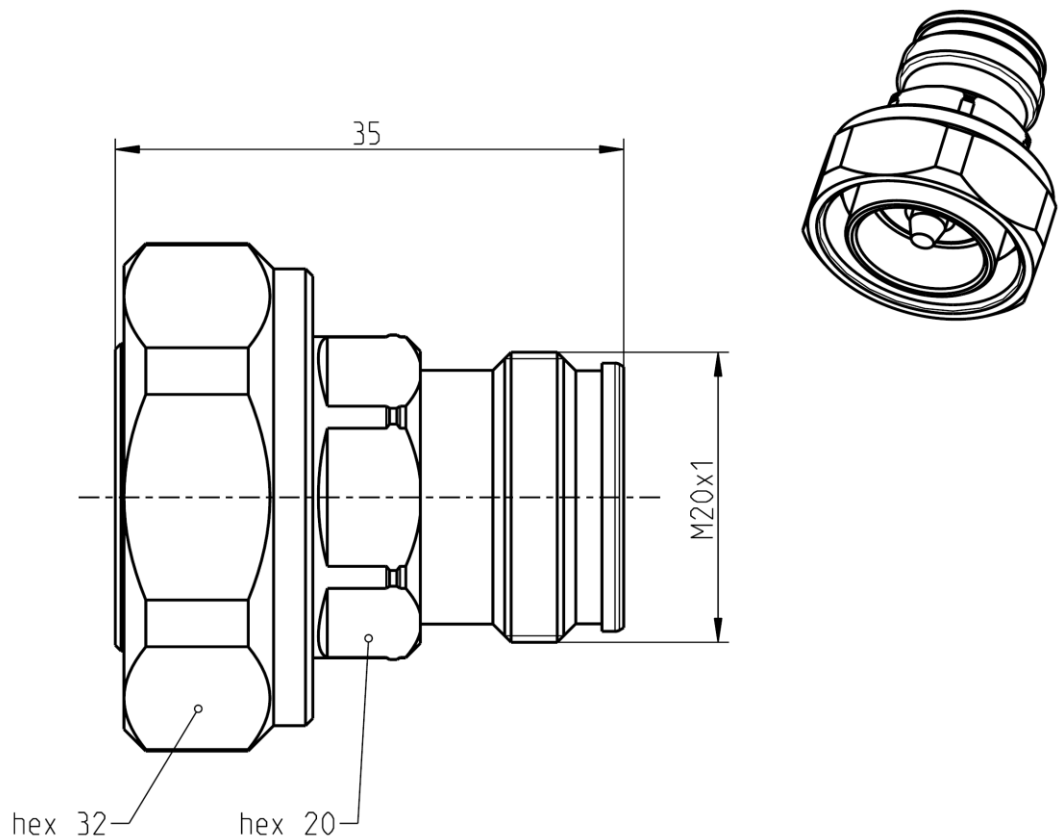

All dimensions are in mm; tolerances according to ISO 2768 m-H

Interface

According to 4.3-10 side: IEC 61169-54
7-16 side: IEC 61169-4, EN 122190, DIN 47223

Documents

N/A

Material and plating

Connector parts

		Material	Plating
Center contact	4.3-10 side:	CuBe	Silver, 3-6 µm
Center contact	7-16 side:	Brass	Silver, 3-6 µm
Outer contact		Brass	Silver, 3-6 µm
Body		Brass	Flash white bronze over silver(e.g. Optargen®)
Dielectric		PTFE	
Gasket		Silicone	

7-16 Adaptor
4.3-10 7-16 Plug – 4.3-10 Jack

60S164-K00N1

Electrical data

Impedance 50 Ω
 Frequency DC to 12 GHz
 Return loss ≥ 36 dB @ DC to 4 GHz
 ≥ 32 dB @ 4 GHz to 6 GHz
 Insertion loss ≤ 0.05 x √ f [GHz] dB
 Insulation resistance ≥ 5 GΩ
 Center contact resistance ≤ 1.0 mΩ, 4.3-10 side ≤ 0.4 mΩ, 7-16 side
 Outer contact resistance ≤ 1.0 mΩ, 4.3-10 side ≤ 1.5 mΩ, 7-16 side
 Test voltage 2500 V rms
 Working voltage 500 V rms
 RF-leakage ≥ 110 dB @ DC to 6 GHz for tool tightened plugs
 ≥ 90 dB @ DC to 3 GHz for tool-less plugs
 ≥ 70 dB @ 3 to 6 GHz for tool-less plugs
 Power handling (at 90 °C, altitude 3000m) 500 W @ 2.0 GHz
 Intermodulation (3rd order) ≥ 160 dBc (2 x 46 dBm) @ 0.4 – 4.0 GHz
 ≥ 166 dBc (2 x 43 dBm) @ 0.4 – 4.0 GHz

- RL value only valid for the interface -

Mechanical data

	4.3-10 side	7-16 side
Mating cycles	≥ 100	min. 500
Center contact captivation: axial	≥ 30 N	≥ 200 N
radial	> 5 Ncm	≥ 2 Ncm
Center contact retention force	1.5 - 20 N	
Recommended torque	5 Nm	25 to 30 Nm
Engagement force	typ. 100 N	N/A
Disengagement force	typ. 80 N	N/A

Environmental data

Temperature range -55 °C to +90 °C operating temperature
 Thermal shock IEC 60169-1, Sub-clause 16.4
 Corrosion resistance ISO 21207 method B
 Vibration IEC 61169-1 9.3.3 and IEC 60068-2-64
 Shock IEC 61169-1 9.3.14
 Degree of protection (mated pair) IEC 60529, IP68 1h / 25m
 RoHS compliant

Tooling

N/A

Suitable cables

N/A

Weight

Weight 73 g/pce

While the information has been carefully compiled to the best of our knowledge, nothing is intended as representation or warranty on our part and no statement herein shall be construed as recommendation to infringe existing patents. In the effort to improve our products, we reserve the right to make changes judged to be necessary.

For the installation of the electrotechnical equipment, particular electrotechnical expertise is required.



Draft	Date	Approved	Date	Rev.	Engineering change number	Name	Date
F. Fraunhofer	29.07.13	Chr. Janßen	02.03.21	b00	20-1927	S. Huber-Siegl	02.03.21

Rosenberger Hochfrequenztechnik GmbH & Co. KG
 P.O.Box 1260 D-84526 Tittmoning Germany
www.rosenberger.com

Tel. : +49 8684 18-0
 Email : info@rosenberger.com

Page
2 / 2