

REVISIONS					
P	LTR	DESCRIPTION	DATE	DMN	APVD
K2		REVISED PER ECO-09-021826	07JAN10	KK	AEG
K3		REVISED PER ECO-20-013196	21SEP20	RK	MZ
K4		REVISED PER ECO-20-013409	23SEP20	RK	MZ

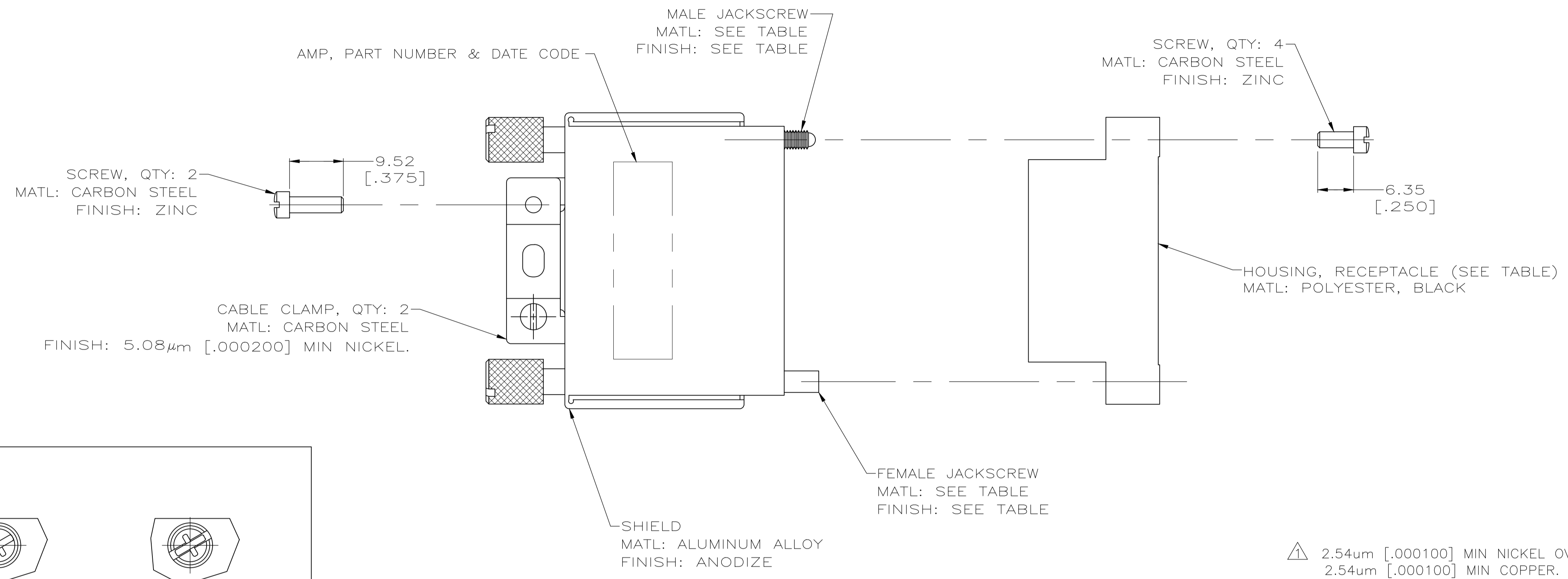

△ 2.54µm [.000100] MIN NICKEL OVER  
2.54µm [.000100] MIN COPPER.

△ OBSOLETE PARTS: OBSOLETE CIS STREAMLINING PER D.RENAUD/D.SINISI

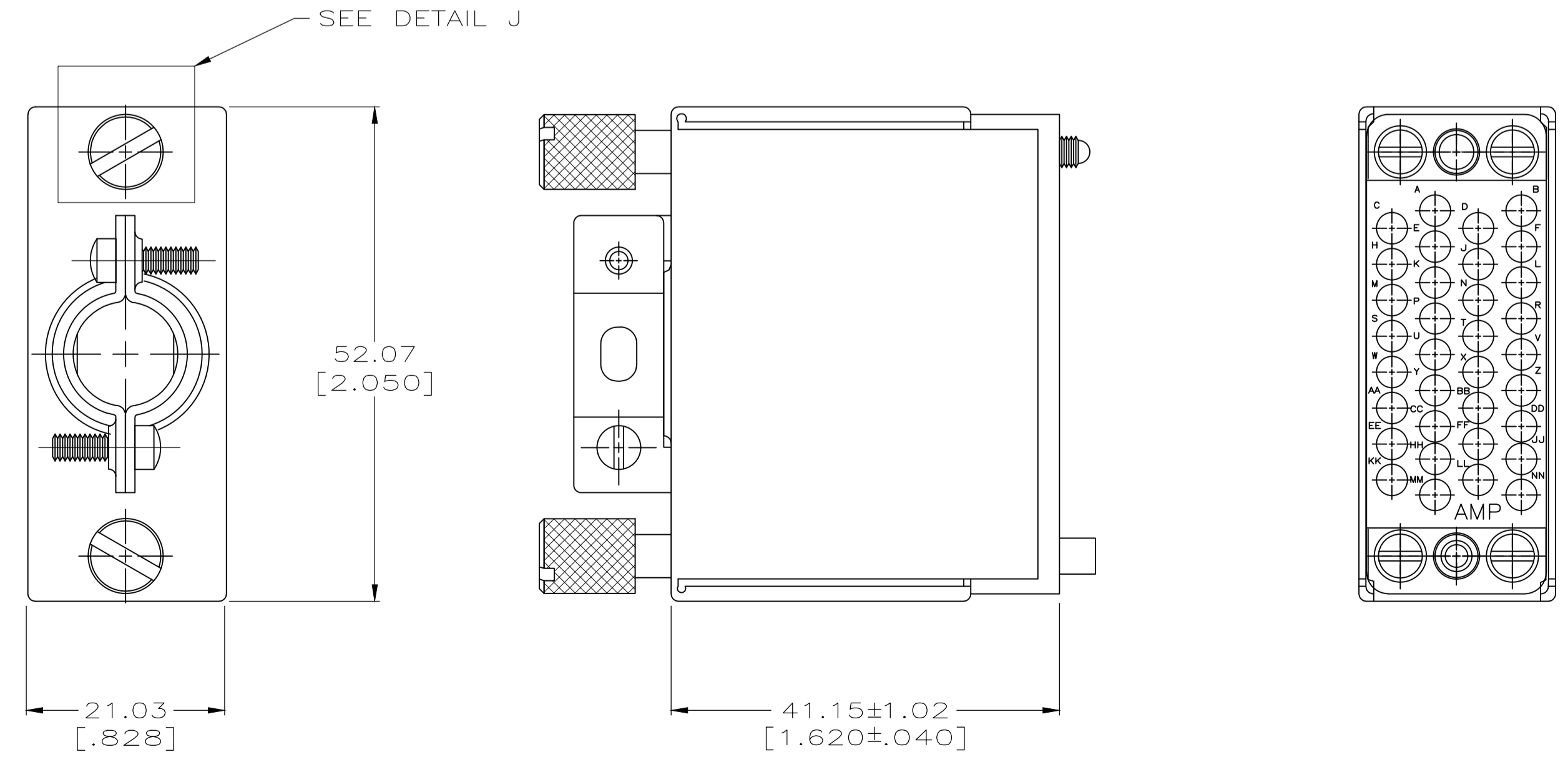
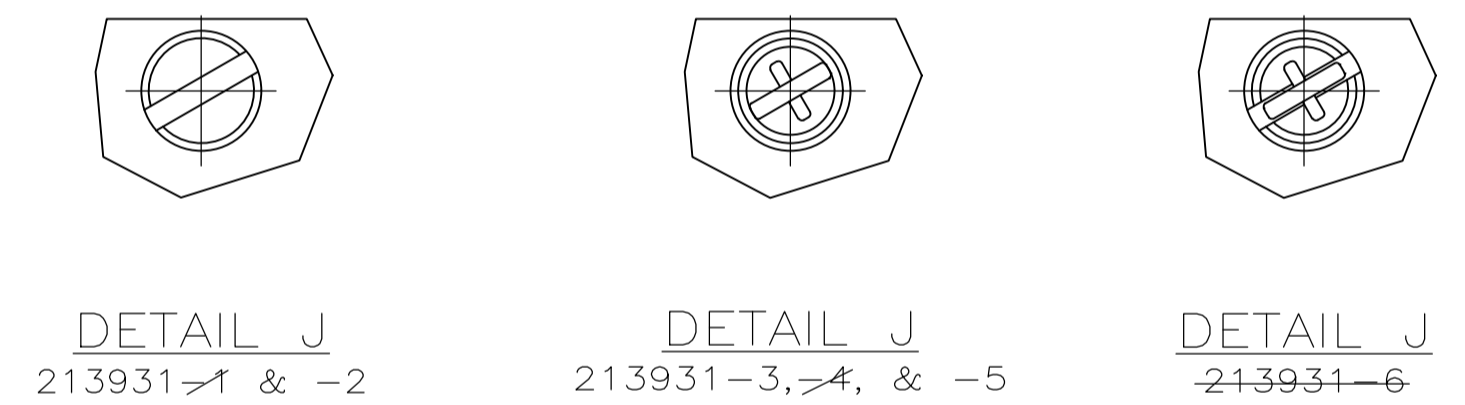

△	OBSOLETE	YES	7.62-11.43 [.300-.450]	BULK	-	STAINLESS STEEL	213931-9-
△	OBSOLETE	YES	11.05-13.84 [.435-.545]	INDIVIDUAL	-	STAINLESS STEEL	213931-8-
△	OBSOLETE	YES	11.05-13.84 [.435-.545]	BULK	△	ZINC	213931-7-
△	OBSOLETE	NO	11.05-13.84 [.435-.545]	INDIVIDUAL	△	ZINC	213931-6
		YES	7.62-11.43 [.300-.450]	INDIVIDUAL	△	ZINC	213931-5
△	OBSOLETE	NO	11.05-13.84 [.435-.545]	INDIVIDUAL	△	ZINC	213931-4-
		YES	11.05-13.84 [.435-.545]	INDIVIDUAL	△	ZINC	213931-3
		YES	7.62-11.43 [.300-.450]	INDIVIDUAL	-	STAINLESS STEEL	213931-2
		YES	11.05-13.84 [.435-.545]	INDIVIDUAL	-	STAINLESS STEEL	213931-1
	RECEPTACLE HOUSING		CABLE RANGE DIA	PACKAGING	FINISH	MATERIAL	PART NUMBER

THIS DRAWING IS A CONTROLLED DOCUMENT.

DMN: D. BROCKWAY 12DEC95  
CHK: C. DORWART 12DEC95

APVD: M. MCALONIS 13DEC95

NAME: CONNECTOR KIT, UNASSEMBLED, RECEPTACLE, 34 POSITION, M SERIES

PRODUCT SPEC: -

APPLICATION SPEC: -

SIZE: A1  
CAGE CODE: 00779  
DRAWING NO: 213931

RESTRICTED TO: -

WEIGHT: -

CUSTOMER DRAWING

SCALE: 2:1  
SHEET: 1 of 1  
REV: K4