

This document is the property of Amphenol Corporation and is delivered on the express condition that is not to be disclosed, reproduced or used, in whole or in part, for manufacture or sale by anyone other than Amphenol Corporation without its prior consent, and that no right is granted to disclose or to use any information in this document.

The marking on this product doesn't contain environmental hazardous materials per directive 2011/65/EU & 2015/863/EU for RoHS compliant and per IEC 61249-2-21 for Halogen-Free compliant.

FOR REFERENCE



REVISIONS				
SYM	ECN No.	DESCRIPTION	DATE	BY
AX1	EDSR#10061	NON-RELEASE REVISION	2021-03-10	Karen Su

NOTES:

- MATERIAL:
 - HOUSING: HIGH TEMPERATURE THERMAL PLASTIC LCP UL94-V0, COLOR: BLACK.
 - CONTACT TERMINAL: HIGH PERFORMANCE COPPER ALLOY.
 - GROUND TERMINAL: STAINLESS STEEL.
 - LATCH: STAINLESS STEEL.
 - SHELL: STAINLESS STEEL.
- FINISH:
 - CONTACT TERMINAL:
 - CONTACT AREA: SELECTIVE PLATING;
 - SOLDERING AREA: GOLD FLASH PLATING. ;
 - UNDER PLATING: NICKEL PLATING 50 μ " THICKNESS MIN.OVERALL.
 - GROUND TERMINAL:
 - SOLDERING AREA: GOLD FLASH PLATING. ;
 - UNDER PLATING: NICKEL PLATING 10 μ " THICKNESS MIN.OVERALL.
 - SHELL:
 - SOLDERING AREA: GOLD FLASH PLATING. ;
 - UNDER PLATING: NICKEL PLATING 10 μ " THICKNESS MIN.OVERALL.
- PRODUCT SPECIFICATION REFER TO : PS-7787.
- TEST SUMMARY REFER TO : TS-7787.
- THIS PRODUCT DOESN'T CONTAIN ENVIRONMENTAL HAZARDOUS PER DIRECTIVE 2011/65/EU & 2015/863/EU FOR RoHS COMPLIANT. AND PER IEC 61249-2-21 FOR HALOGEN-FREE COMPLIANT.

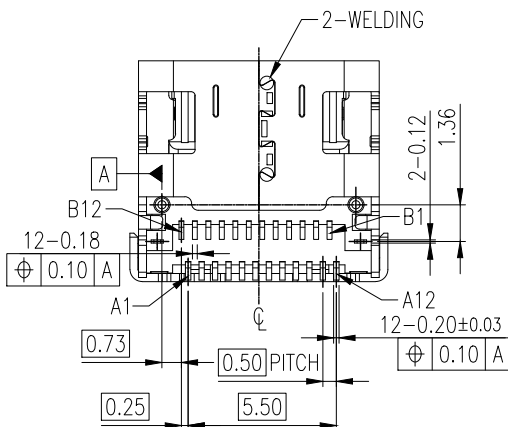
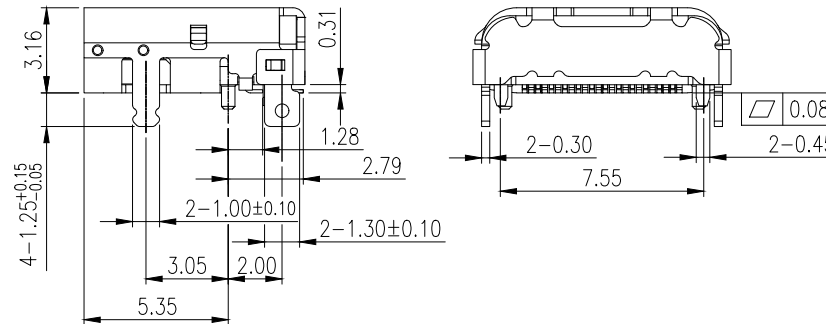
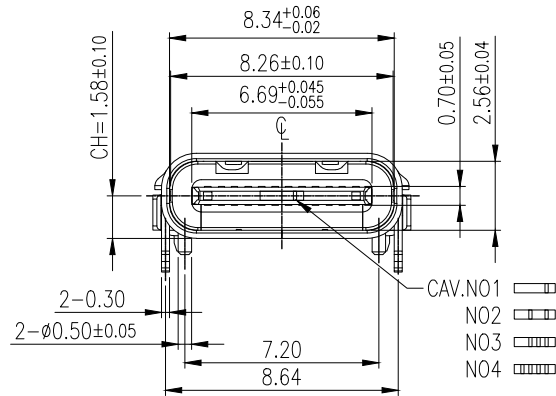
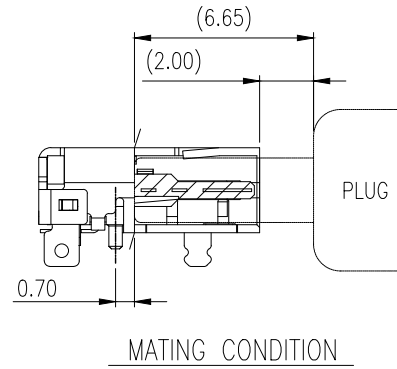
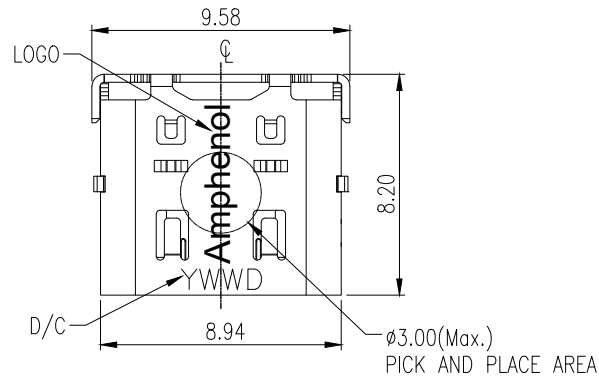

P/N : GSB4D31 3 302 A Y1HR
 CONTACT FINISH 3: 30 μ " GOLD
 SHELL TAIL LENGTH A: 1.25mm

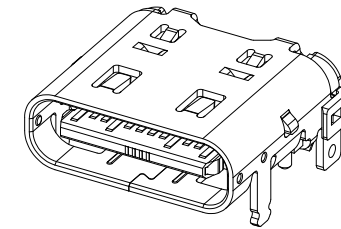

TOLERANCE	DRAWN	APPROVALS	DATE	TITLE	UNIT	SIZE	PART No.
X. ±0.30	DESIGNED	Karen Su	2021-03-10	USB TYPE-C (USB4 GEN3) RECEPTACLE R/A DUAL ROW SMT TYPE, CH=1.58mm, SHELL TAIL LENGTH=1.25	mm	A3	GSB4D313302AY1HR
X.XX ±0.20	CHECKED	Aqua Chou	2021-03-10				
X.XXX ±0.10	APPROVED	Roger Tsai	2021-03-10				
ANGULAR ±2°	DWG TYPE	CUST DWG	PROJECT CODE	OTHER	SCALE	SHEET	DWG No.
UNLESS OTHERWISE SPECIFIED					NA	1 OF 3	GSB4D313302AY1HR

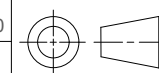

This document is the property of Amphenol Corporation and is delivered on the express condition that it is not to be disclosed, reproduced or used, in whole or in part, for manufacture or sale by anyone other than Amphenol Corporation without its prior consent, and that no right is granted to disclose or to use any information in this document.

The marking on this product doesn't contain environmental hazardous materials per directive 2011/65/EU & 2015/863/EU for RoHS compliant and per IEC 61249-2-21 for Halogen-Free compliant.

FOR REFERENCE



REVISIONS				
SYM	ECN No.	DESCRIPTION	DATE	BY
AX1	EDSR#10061	NON-RELEASE REVISION	2021-03-10	Karen Su

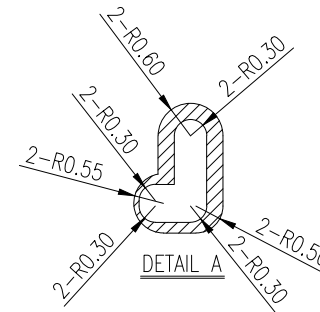
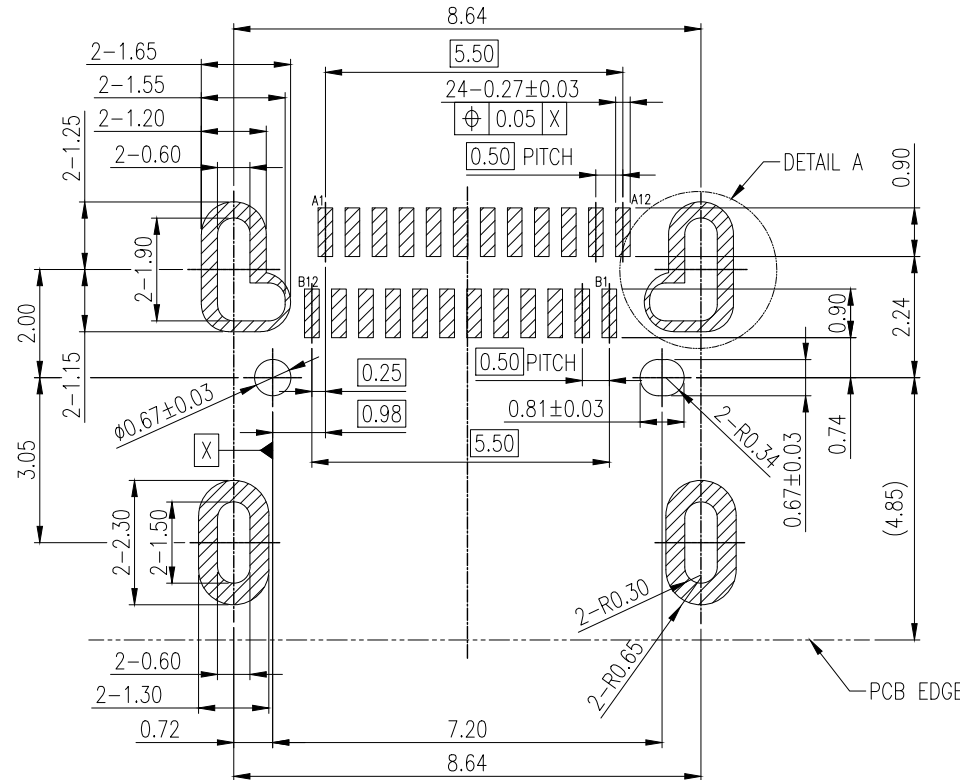

PIN ASSIGNMENT											
A1	A2	A3	A4	A5	A6	A7	A8	A9	A10	A11	A12
GND	TX1+	TX1-	VBUS	CC1	D+	D-	RFU1	VBUS	RX2-	RX2+	GND
GND	RX1+	RX1-	VBUS	SBU2	D-	D+	CC2	VBUS	TX2-	TX2+	GND
B12	B11	B10	B9	B8	B7	B6	B5	B4	B3	B2	B1

RECOMMENDED PCB LAYOUT (TOP VIEW)
 TOLERANCE: ±0.05mm
 (PCB THICKNESS 0.80±0.05mm)
 SCALE 2:1

TOLERANCE X. ±0.30 X.X ±0.20 X.XX ±0.10 X.XXX ±0.10 ANGULAR ±2° UNLESS OTHERWISE SPECIFIED	DRAWN APPROVALS DATE	TITLE USB TYPE-C (USB4 GEN3) RECEPTACLE R/A DUAL ROW SMT TYPE, CH=1.58mm, SHELL TAIL LENGTH=1.25		Amphenol® Amphenol Corporation Amphenol Taiwan Corporation		
	DESIGNED Karen Su 2021-03-10	PROJECT CODE OTHER		UNIT mm	SIZE A3	PART No. GSB4D313302AY1HR
	CHECKED Aqua Chou 2021-03-10	APPROVED Roger Tsai 2021-03-10	DWG TYPE CUST DWG	SCALE NA	SHEET 2 OF 3	REV. AX1
	DWG No. GSB4D313302AY1HR	DWG No. GSB4D313302AY1HR				

This document is the property of Amphenol Corporation and is delivered on the express condition that is not to be disclosed, reproduced or used, in whole or in part, for manufacture or sale by anyone other than Amphenol Corporation without its prior consent, and that no right is granted to disclose or to use any information in this document.

The marking on this product doesn't contain environmental hazardous materials per directive 2011/65/EU & 2015/863/EU for RoHS compliant and per IEC 61249-2-21 for Halogen-Free compliant.

FOR REFERENCE



REVISIONS				
SYM	ECN No.	DESCRIPTION	DATE	BY
AX1	EDSR#10061	NON-RELEASE REVISION	2021-03-10	Karen Su

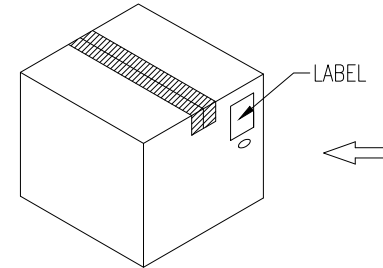
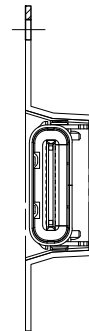
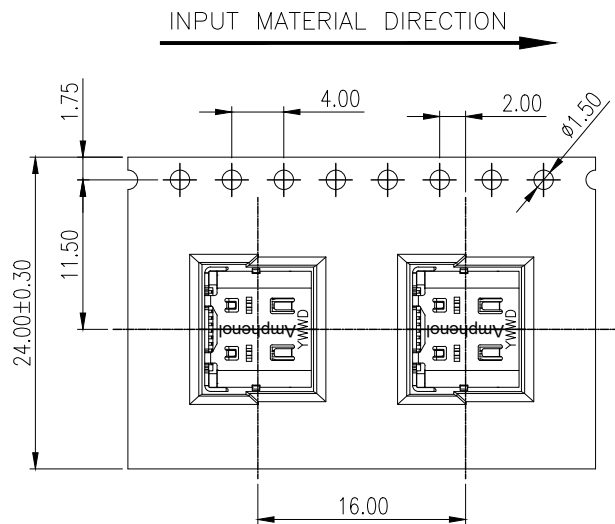
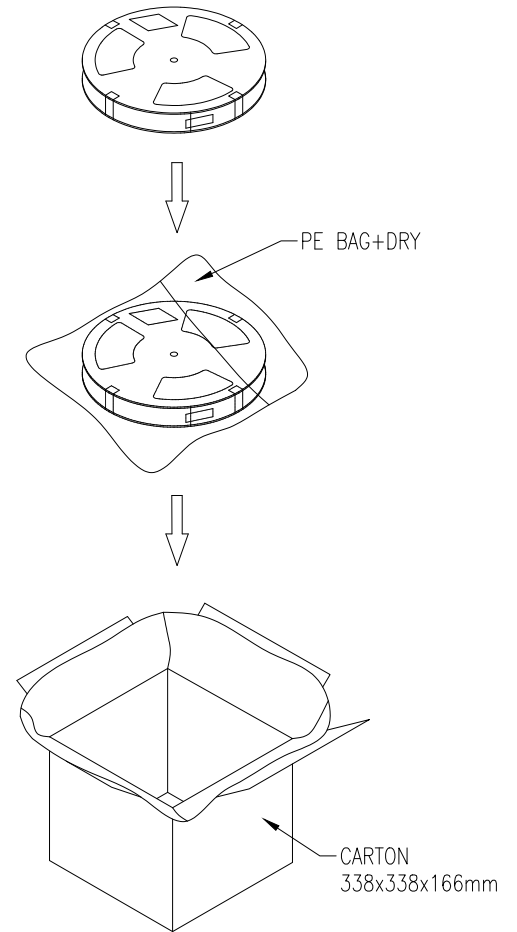
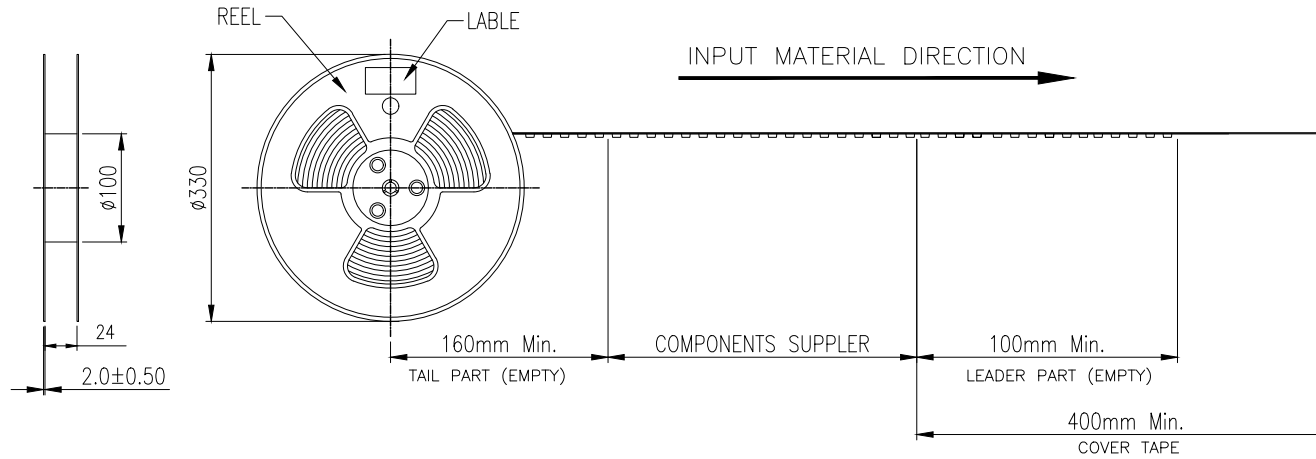

- NOTES:
1. THE COVER TAPE OF CARRIER TAPE SHALL HAVE A TOTAL PEEL STRENGTH OF FROM 10~130G.
 2. THE DIRECTION OF PULL SHALL BE OPPOSITE THE DIRECTION OF CARRIER TAPE TRAVEL SUCH THAT THE COVER TAPE MAKES AN ANGLE OF BETWEEN 165 AND 180 DEGREES WITH THE TOP OF THE CARRIER TAPE.
 3. PEELING SPEED: 300MM/MINUTES.
 4. ALL DIMENSIONS MEET EIA-481-D REQUIREMENTS.

TOLERANCE	DRAWN	APPROVALS	DATE	TITLE		Amphenol®				
X. X.X X.XX ±0.30 X.XXX ±0.20 X.XXX ±0.10	DESIGNED	Karen Su	2021-03-10	USB TYPE-C (USB4 GEN3) RECEPTACLE R/A DUAL ROW SMT TYPE, CH=1.58mm, SHELL TAIL LENGTH=1.25		Amphenol Corporation Amphenol Taiwan Corporation				
	CHECKED	Aqua Chou	2021-03-10							
ANGULAR ±2°	APPROVED	Roger Tsai	2021-03-10	UNIT	mm	SIZE	A3	PART No. GSB4D313302AY1HR		
UNLESS OTHERWISE SPECIFIED	DWG TYPE	CUST DWG	PROJECT CODE	OTHER	SCALE	NA	SHEET	3 OF 3	DWG No. GSB4D313302AY1HR	REV. AX1