

Description

The DIODES ZXCT199Q series are automotive AEC-Q qualified current shunt monitors which are designed to deal with very low sense voltages, enabling the use of very low value sense resistors to monitor large currents. The low offset voltage and zero-drift architecture enables current sensing with maximum drops across the shunt to as low as 10mV full-scale.

The ZXCT199Q series have three fixed voltage gain options in 50V/V, 100V/V, and 200V/V. They can measure voltage across shunts at common-mode voltages from -0.1V to 26V, independent of supply voltage.

OUT pin is a voltage proportional to the load current. It can then be processed with an ADC. These devices are designed with zero-drift architecture and manufactured by post trim technology to achieve low offset voltage, low gain drift and low gain error over full temperature range for precise measurement.

These devices operate from a 2.7V to 26V power supply with a maximum supply current of 100 μ A. All versions have a temperature range of -40°C to +125°C, and are offered in the SOT363 package.

The ZXCT199Q has been qualified to AEC-Q100 Grade 1 and is automotive grade supporting PPAPs.

Features

- Supply Voltage Range: 2.7V to 26V
- Wide Common-Mode Range: -0.1V to 26V
- Gain Error: (Maximum over Temperature Range)
 - A and B Versions: $\pm 1.0\%$
 - C Version: $\pm 0.8\%$
- Choices of Gains:
 - ZXCT 199QX1: 50V/V
 - ZXCT 199QX2: 100V/V
 - ZXCT 199QX3: 200V/V
- Low Offset Voltage
 - A Version max $\pm 150\mu$ V
 - B Version max $\pm 100\mu$ V
 - C Version max $\pm 80\mu$ V
- Zero-Drift Performance: 0.5 μ V/°C (max)
- Rail-to-Rail Output Capability
- Low Quiescent Current: 100 μ A (max)
- Package: 6-Pin SOT363
- **Totally Lead-Free & Fully RoHS Compliant (Notes 1 & 2)**
- **Halogen and Antimony Free. "Green" Device (Note 3)**
- **The ZXCT199Q is suitable for automotive applications requiring specific change control; this part is AEC-Q100 qualified, PPAP capable, and manufactured in IATF16949 certified facilities.**

<https://www.diodes.com/quality/product-definitions/>

- Notes:
1. No purposely added lead. Fully EU Directive 2002/95/EC (RoHS), 2011/65/EU (RoHS 2) & 2015/863/EU (RoHS 3) compliant.
 2. See <https://www.diodes.com/quality/lead-free/> for more information about Diodes Incorporated's definitions of Halogen- and Antimony-free, "Green" and Lead-free.
 3. Halogen- and Antimony-free "Green" products are defined as those which contain <900ppm bromine, <900ppm chlorine (<1500ppm total Br + Cl) and <1000ppm antimony compounds.

Pin Assignments

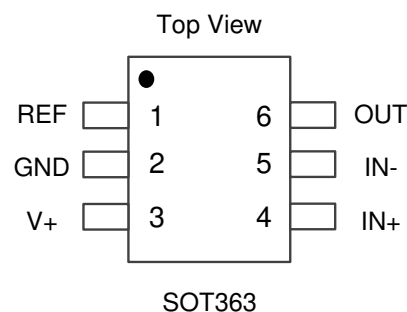

Applications

The ZXCT199Q is well suited for power supplies running at large current flow requiring the use of low-value sense resistors.

- Vehicle valve controls
- Vehicle body control systems
- Vehicle motor controls, e-pumps
- Vehicle e-compressors
- Vehicle ADAS
- EV OBC, BMS, ESP, high voltage DC/DC
- Wireless charging
- Current sensing (high-side/low-side)
- Battery charging and discharging

Typical Applications Circuit

| Part Number | Gain Option | Gain | Gain Error | V _{OS} | Gain Drift |
|-------------|-------------|------|------------|-----------------|------------|
| | | V/V | % | μV | ppm/°C |
| ZXCT199QA | 1 | 50 | 1.0 | ±150 | 10 |
| | 2 | 100 | 1.0 | ±150 | 10 |
| | 3 | 200 | 1.0 | ±150 | 10 |
| ZXCT199QB | 1 | 50 | 1.0 | ±100 | 10 |
| | 2 | 100 | 1.0 | ±100 | 10 |
| | 3 | 200 | 1.0 | ±100 | 10 |
| ZXCT199QC | 1 | 50 | 0.8 | ±80 | 10 |
| | 2 | 100 | 0.8 | ±80 | 10 |
| | 3 | 200 | 0.8 | ±80 | 10 |

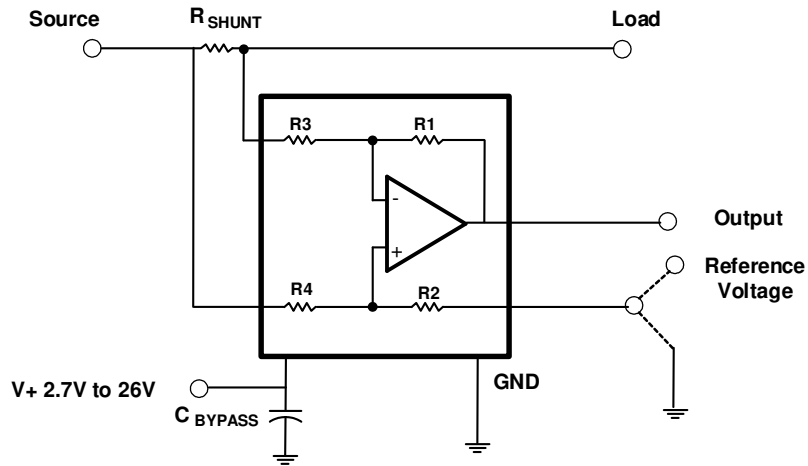

Practical Values of CBYPASS 0.01μF to 0.1μF

$$V_{OUT} = (I_{LOAD} \times R_{SENSE}) \text{ GAIN} + V_{REF}$$

Pin Descriptions

| Pin Name | Pin Number | I/O | Description |
|----------|------------|---------------|---|
| REF | 1 | Analog input | Reference voltage, 0V to V+ |
| GND | 2 | — | Ground |
| V+ | 3 | Power | Power supply, 2.7V to 26V |
| IN+ | 4 | Analog input | Connect to supply side of shunt resistor. |
| IN- | 5 | Analog input | Connect to load side of shunt resistor. |
| OUT | 6 | Analog output | Output voltage |

Absolute Maximum Ratings (@ $T_A = +25^\circ\text{C}$, unless otherwise specified.) (Note 4)

| Description | Rating | Unit |
|---|------------------------------------|---------------------------|
| Supply Voltage (V_+) | +26 | V |
| Analog Inputs IN_+ , IN_- | Differential (IN_+)-(IN_-) | -26 to 26 |
| | Common Mode | GND -0.3 to 26 |
| REF Input Voltage | GND - 0.3 to (V_+) + 0.3 | V |
| Output | GND - 0.3 to (V_+) + 0.3 | V |
| Input Current into All Pins (Note 5) | 5 | mA |
| ESD Human Body ESD Protection (HBM) | 5 | kV |
| ESD Charged-Device Model ESD Protection (CDM) | 1.5 | kV |
| $R_{\theta JA}$ (Junction-to-Ambient Thermal Resistance) (Note 6) | 228 | $^\circ\text{C}/\text{W}$ |
| $R_{\theta JC}$ (Junction-to-Case Thermal Resistance) (Note 6) | 72 | $^\circ\text{C}/\text{W}$ |
| Operating Temperature | -40 to +125 | $^\circ\text{C}$ |
| Storage Temperature | -65 to +150 | $^\circ\text{C}$ |

- Notes:
- Stresses greater than those listed under *Absolute Maximum Ratings* can cause permanent damage to the device. These are stress ratings only, and functional operation of the device at these or any other conditions beyond those indicated under *Recommended Operating Conditions* is not implied. Exposure to *Absolute Maximum Ratings* for extended periods can affect device reliability.
 - Input voltage at any pin can exceed the voltage shown if the current at that pin is limited to 5mA.
 - $R_{\theta JA}$ and $R_{\theta JC}$ are measured at $T_A = +25^\circ\text{C}$ on a high effective thermal conductivity minimum recommend pad (MRP) FR-4 PC board.

Recommended Operating Conditions (Note 7)

| Symbol | Parameter | Min | Typ | Max | Unit |
|----------|--|------|-----|------|------------------|
| V_{CM} | Common-Mode Input Voltage | -0.1 | 12 | 26 | V |
| V_S | Operating Supply Voltage (Applied to V_+) | 2.7 | 5 | 26 | V |
| T_A | Operating Ambient Temperature | -40 | — | +125 | $^\circ\text{C}$ |

- Note: 7. Refer to the *Typical Applications Circuit*.

Electrical Characteristics ($T_A = +25^\circ\text{C}$, $V_S = 5\text{V}$, $V_{IN+} = 12\text{V}$, $V_{SENSE} = V_{IN+} - V_{IN-}$, and $V_{REF} = V_S/2$, unless otherwise noted.)

| Symbol | Parameter | Test Conditions | Min | Typ | Max | Unit |
|--------------|----------------------------------|---|------|---------------------|--------------------|------------------------------|
| V_{CM} | Common-mode input | $T_A = -40^\circ\text{C}$ to $+125^\circ\text{C}$ | -0.1 | — | 26 | V |
| CMRR | Common-mode rejection | ZXCT199QX1, $V_{IN+} = 0\text{V}$ to 26V $V_{SENSE} = 0\text{mV}$, $T_A = -40^\circ\text{C}$ to $+125^\circ\text{C}$ | 90 | 120 | — | dB |
| | | ZXCT199QX2, $V_{IN+} = 0\text{V}$ to 26V $V_{SENSE} = 0\text{mV}$, $T_A = -40^\circ\text{C}$ to $+125^\circ\text{C}$ | 100 | 120 | — | dB |
| | | ZXCT199QX3, $V_{IN+} = 0\text{V}$ to 26V $V_{SENSE} = 0\text{mV}$, $T_A = -40^\circ\text{C}$ to $+125^\circ\text{C}$ | 105 | 120 | — | dB |
| V_{OS} | Offset voltage, RTI (Note 8) | ZXCT199QA Version, $V_{SENSE} = 0\text{mV}$ | — | ± 5 | ± 150 | μV |
| | | ZXCT199QB Version, $V_{SENSE} = 0\text{mV}$ | — | ± 5 | ± 100 | μV |
| | | ZXCT199QC Version, $V_{SENSE} = 0\text{mV}$ | — | ± 5 | ± 80 | μV |
| dV_{OS}/dT | V_{OS} vs. temperature | $T_A = -40^\circ\text{C}$ to $+125^\circ\text{C}$ | — | 0.1 | 0.5 | $\mu\text{V}/^\circ\text{C}$ |
| — | Long-term stability (Note 9) | — | — | — | 270 | μV |
| PSRR | Power supply rejection | $V_S = 2.7\text{V}$ to 18V $V_{IN+} = 18\text{V}$, $V_{SENSE} = 0\text{mV}$ | — | ± 0.1 | — | $\mu\text{V}/\text{V}$ |
| I_B | Input bias current | $V_{SENSE} = 0\text{mV}$ | — | 28 | — | μA |
| I_{OS} | Input offset current | $V_{SENSE} = 0\text{mV}$ | — | ± 0.02 | — | μA |
| G | Gain | ZXCT199QX1 | — | 50 | — | V/V |
| | | ZXCT199QX2 | — | 100 | — | |
| | | ZXCT199QX3 | — | 200 | — | |
| E_G | Gain error | A and B Version, $V_{SENSE} = -5\text{mV}$ to 5mV $T_A = -40^\circ\text{C}$ to 125°C | — | $\pm 0.03\%$ | $\pm 1\%$ | — |
| | | C Version, $V_{SENSE} = -5\text{mV}$ to 5mV $T_A = -40^\circ\text{C}$ to $+125^\circ\text{C}$ | — | $\pm 0.03\%$ | $\pm 0.8\%$ | — |
| — | Gain error vs. temperature | $T_A = -40^\circ\text{C}$ to $+125^\circ\text{C}$ | — | 3 | 10 | ppm/ $^\circ\text{C}$ |
| — | Nonlinearity error | $V_{SENSE} = -5\text{mV}$ to 5mV | — | $\pm 0.01\%$ | — | — |
| V_{OH} | Swing to V_+ power-supply rail | $R_L = 10\text{k}\Omega$ to GND, $T_A = -40^\circ\text{C}$ to $+125^\circ\text{C}$ | — | $(V_+) - 0.05$ | $(V_+) - 0.2$ | V |
| V_{OL} | Swing to GND | $R_L = 10\text{k}\Omega$ to GND, $T_A = -40^\circ\text{C}$ to $+125^\circ\text{C}$ | — | $(V_{GND}) + 0.005$ | $(V_{GND}) + 0.05$ | V |
| — | Maximum capacitive load | No sustained oscillation | — | 1 | — | nF |
| GBW | Band width | $C_{LOAD} = 10\text{pF}$, ZXCT199QX1 | — | 70 | — | kHz |
| | | $C_{LOAD} = 10\text{pF}$, ZXCT199QX2 | — | 30 | — | |
| | | $C_{LOAD} = 10\text{pF}$, ZXCT199QX3 | — | 14 | — | |
| SR | Slew rate | — | — | 0.5 | — | V/ μs |
| — | Voltage noise density | — | — | 25 | — | nV/ $\sqrt{\text{Hz}}$ |
| V_S | Operating voltage range | $T_A = -40^\circ\text{C}$ to $+125^\circ\text{C}$ | 2.7 | — | 26 | V |
| | | -20°C to $+85^\circ\text{C}$ | 2.5 | — | 26 | |
| I_Q | Quiescent current | $V_{SENSE} = 0\text{mV}$ | — | 65 | 100 | μA |
| | | $T_A = -40^\circ\text{C}$ to $+125^\circ\text{C}$ | — | — | 115 | μA |
| — | Specified range | — | -40 | — | +125 | $^\circ\text{C}$ |
| — | Operating range | — | -40 | — | +125 | $^\circ\text{C}$ |

Notes: 8. RTI = Referred to input.
9. Only for ZXCT199QX1, the long-term stability is defined as MAX. V_{OS} shift during life test 1000 hours with $T_A = +125^\circ\text{C}$. This V_{OS} drift with time is not a linear function of time, and the shift is greater initially and diminishes over time. This parameter is guaranteed by design.

Typical Performance Characteristics

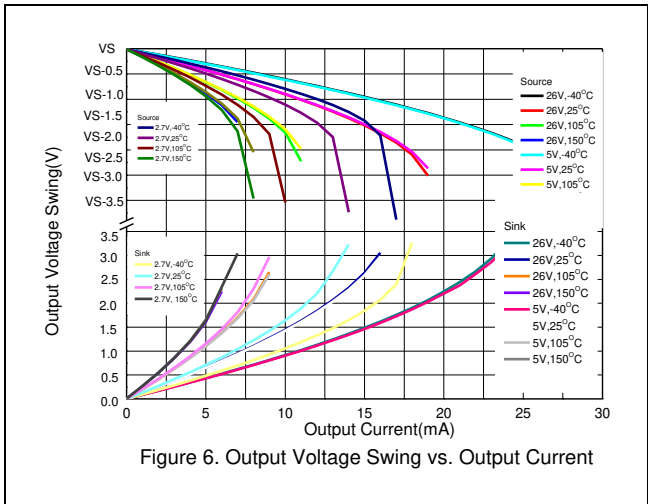
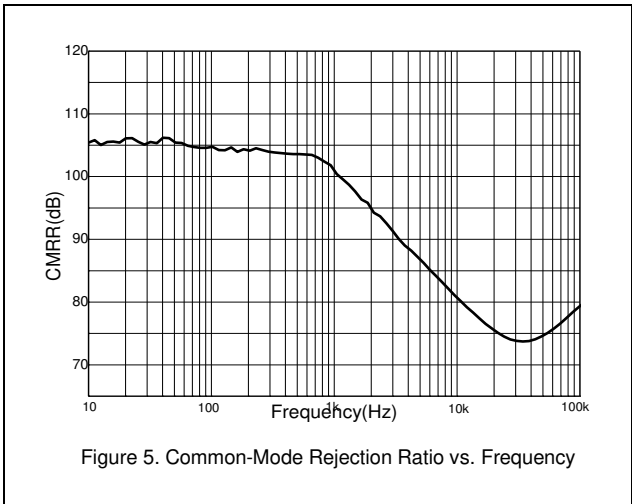
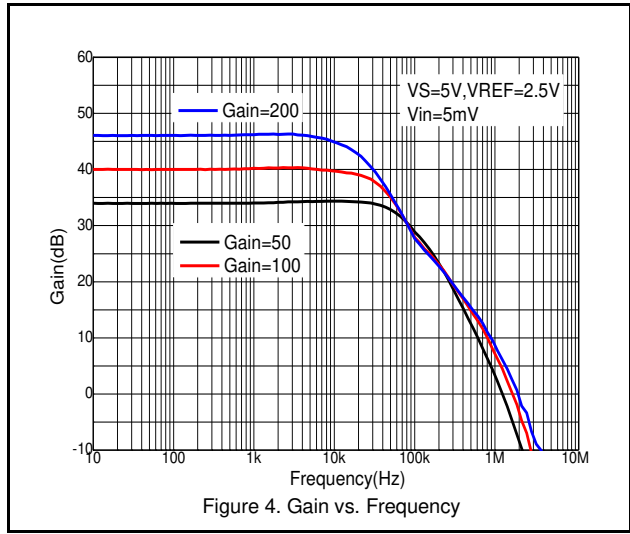
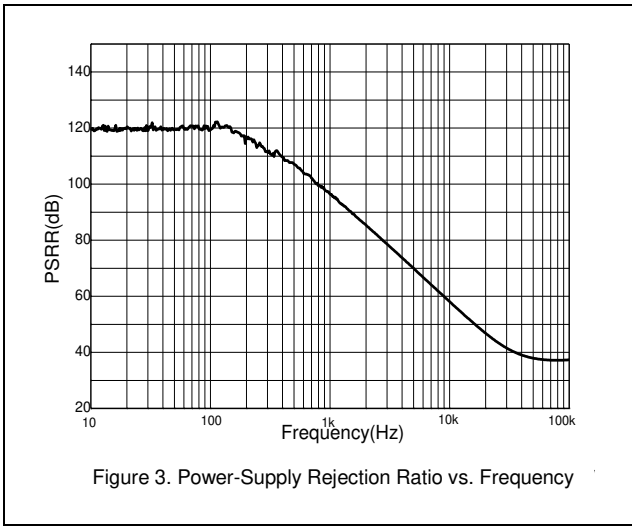
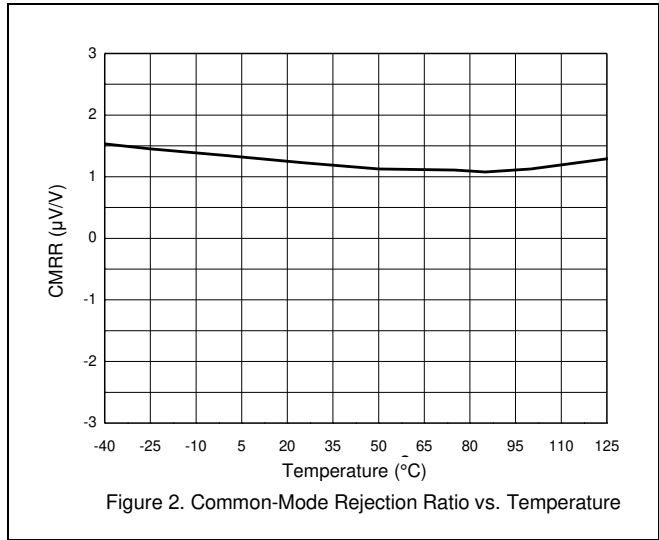
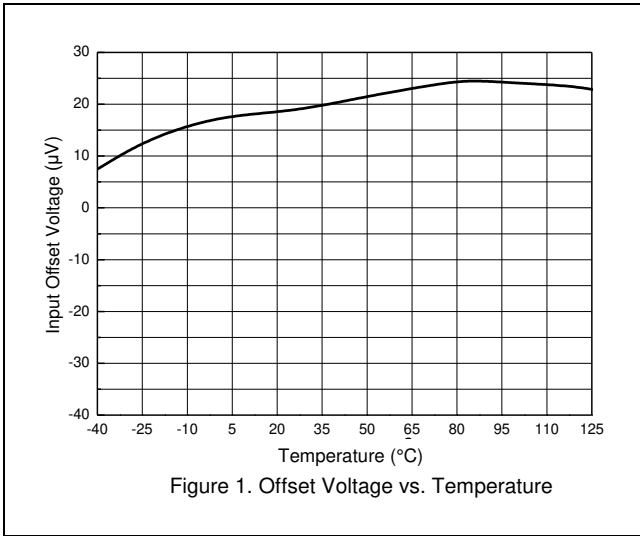

Typical Performance Characteristics (continued)

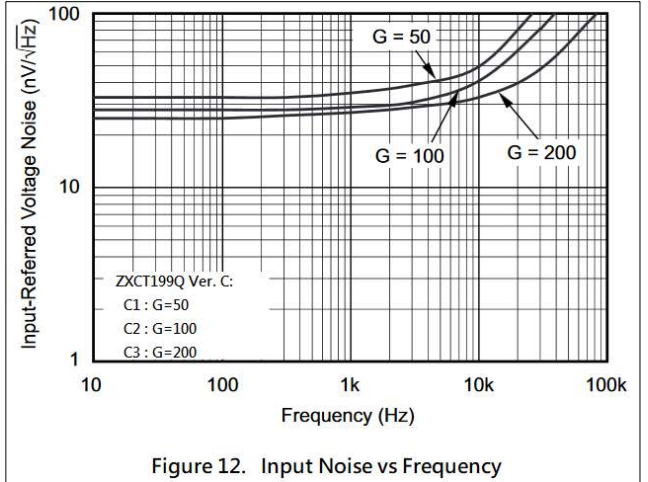
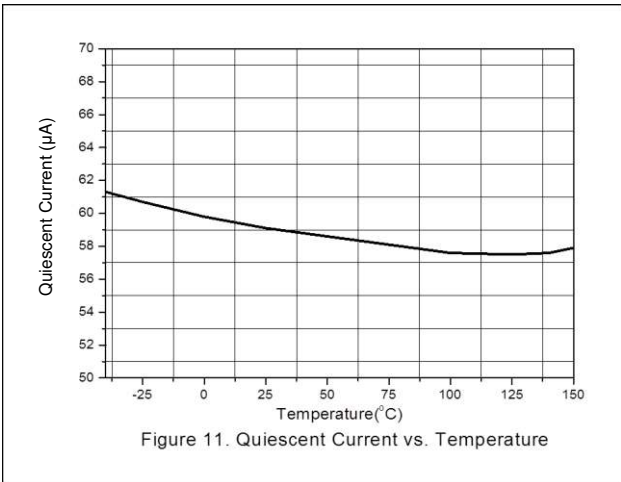
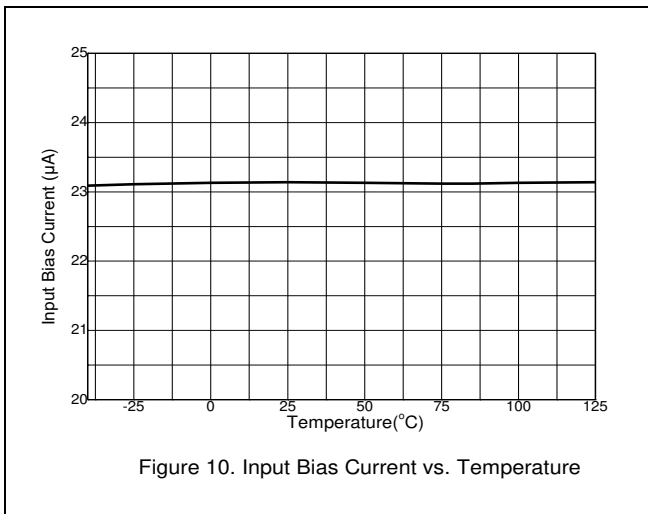
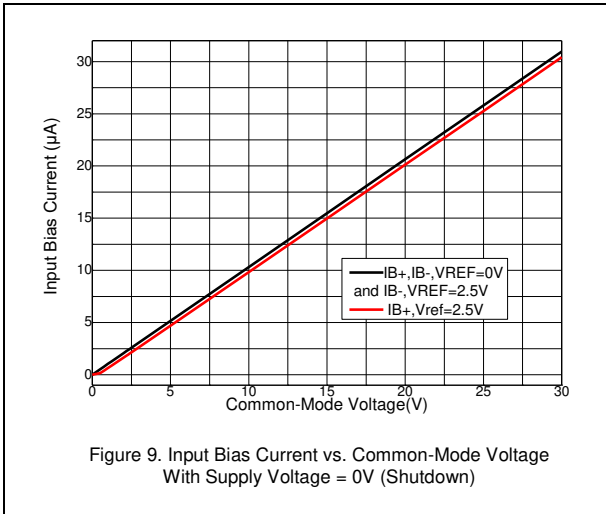
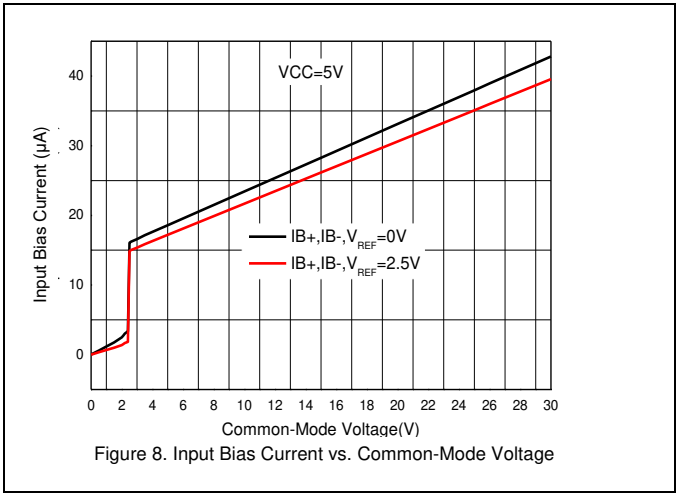
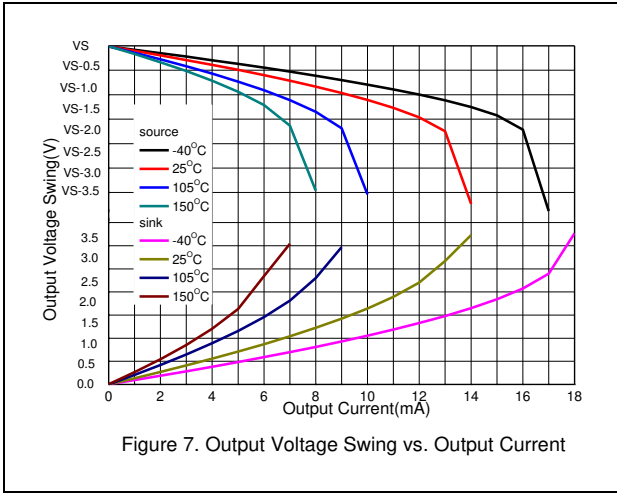

Typical Performance Characteristics (continued)

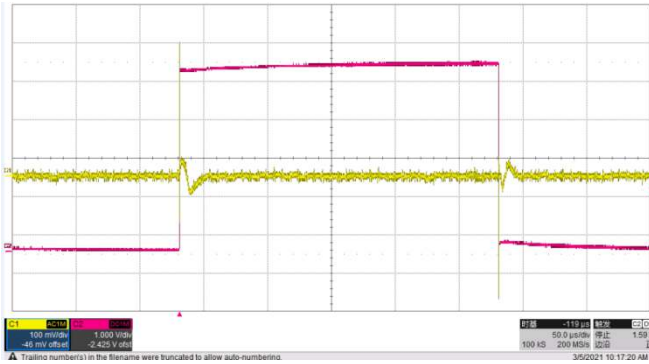

Figure 13. Common-Mode Voltage vs Transient Response

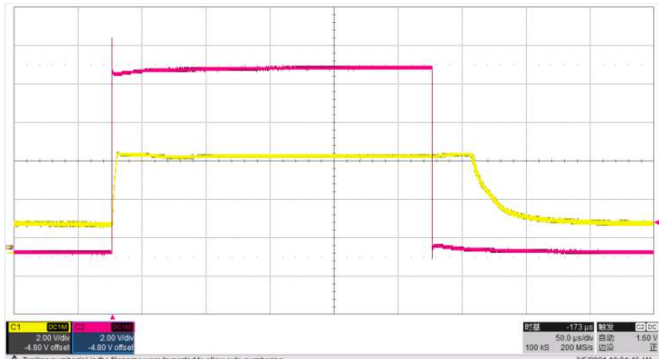

Figure 14. Noninverting Differential Input Overload

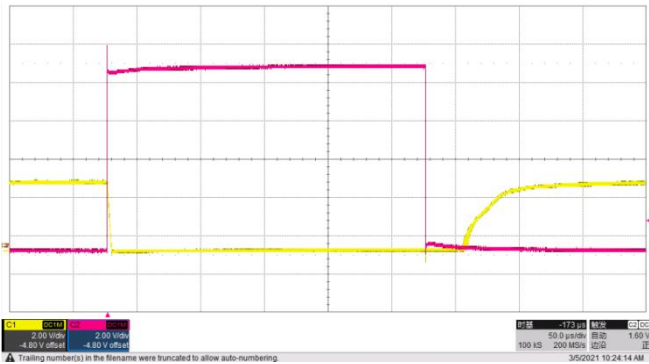

Figure 15. Inverting Differential Input Overload

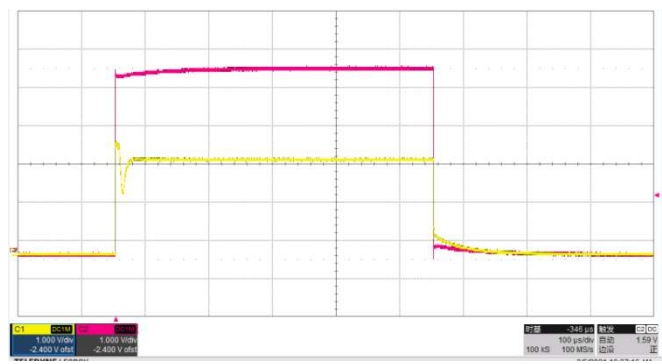

Figure 16. Startup Response

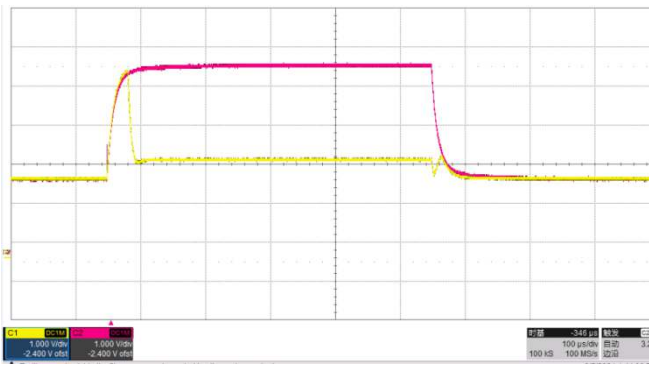

Figure 17. Brownout Recovery

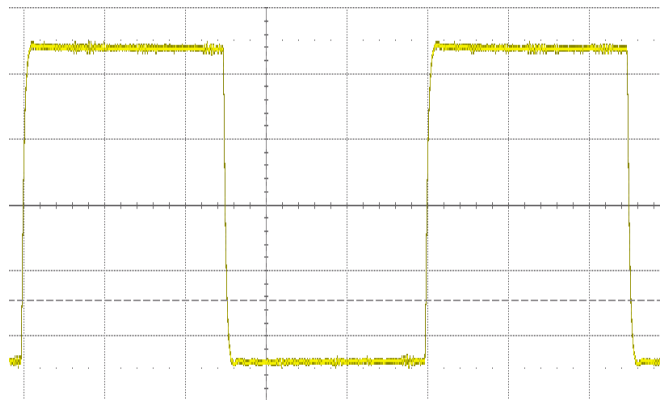

Figure 18. Output Stability with Load 2.2nF

Application Information

General Information

The ZXCT199Q has a wide common mode of -0.1V to 26V and it can be used in low-side and high-side current sensing. The device is a specially designed, current-sensing amplifier that is able to accurately measure voltages developed across a current-sensing resistor on common-mode voltages that far exceed the supply voltage powering the device. The zero-drift topology enables high-precision measurements with maximum input offset voltages as low as 80 μ V with a maximum temperature contribution of 0.5 μ V/ $^{\circ}$ C over the full temperature range of -40 $^{\circ}$ C to +125 $^{\circ}$ C.

Input and Output Pin Voltage Ranges

The ZXCT199Q can withstand the full input signal range up to 26V at the input pins, regardless of whether the device has power applied or has the V+ pin at zero volt. The input circuitry of the ZXCT199Q can accurately measure beyond its power-supply voltage. For example, the V+ power supply can be 5V, whereas the voltage applied to the analog input pins IN+ or IN- can be as high as 26V. However, the output voltage range of the OUT pin is limited by the voltage on the power supply and a consideration of the maximum V_{OH}. An alternative to having a low supply voltage just to protect a converter would be to use a voltage divider at the output of the ZXCT199Q.

Power Supply Recommendations

The ZXCT199Q can operate on as low as 2.7V. In some applications the power supply may be selected to limit the output range that is compatible with parts using this signal such as an analog converter or an analog input pin on a microcontroller. In Figure 19 the power supply has been set at 5V. This will limit the output voltage of the current monitor giving protection to the converter. The ground connections for the ADC and current monitor should be wired as a star configuration to minimize error. A power-supply bypass capacitor connected closely to the device pins is required for stability with a suggested value of 0.01 μ F to 0.1 μ F. Applications with noisy or high-impedance power supplies may require additional decoupling capacitors to reject power-supply noise.

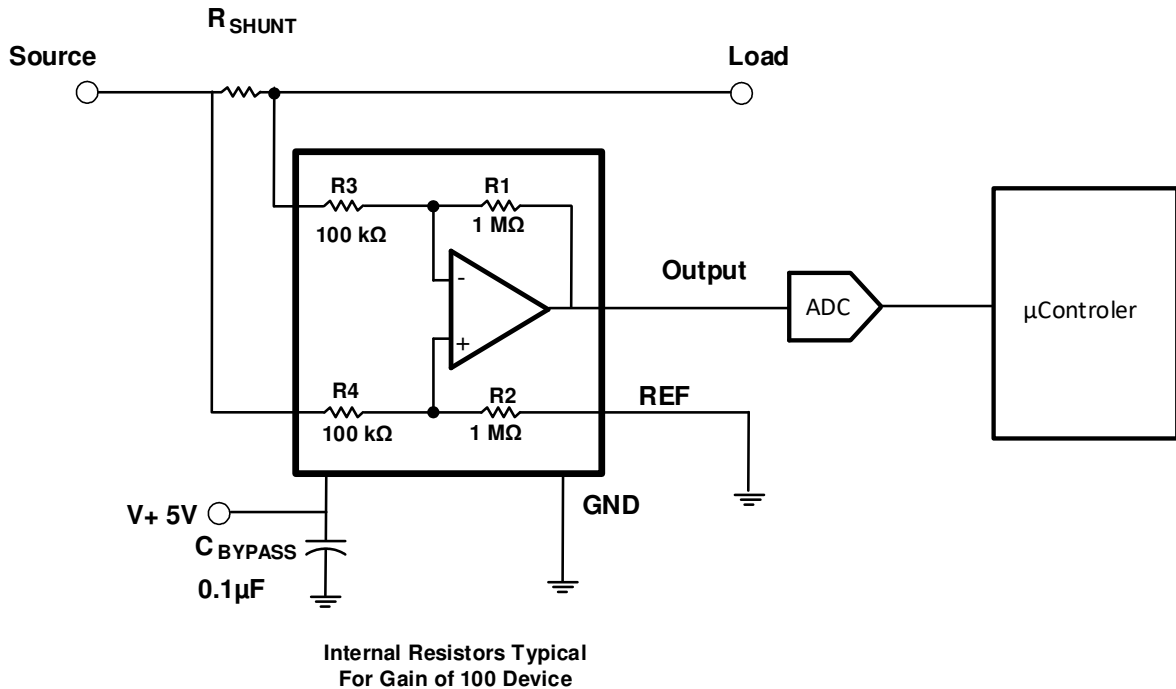

Figure 19. Typical Application

Application Information (continued)

Single Direction Operation

The device is configured to monitor current flowing in one direction (single direction) or in both directions (bidirectional) depending on how the REF pin is configured. With REF connected to ground as depicted in Figure 20, the device will measure only signals that impose a positive voltage across the shunt.

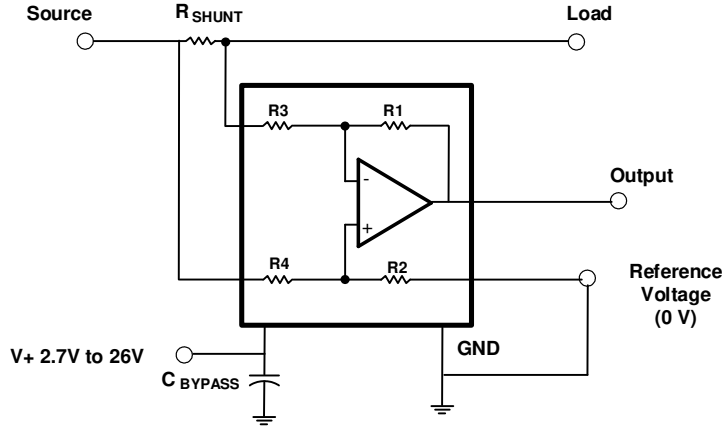

Figure 20. Single Direction Application Schematic Using Ground as a Reference

An example output response of a single directional configuration is shown in Figure 21. With the REF pin connected directly to ground, the output voltage is biased to this zero output level. The output rises above the reference voltage for positive differential input signals but cannot fall below the reference voltage for negative differential input signals because of the grounded reference voltage.

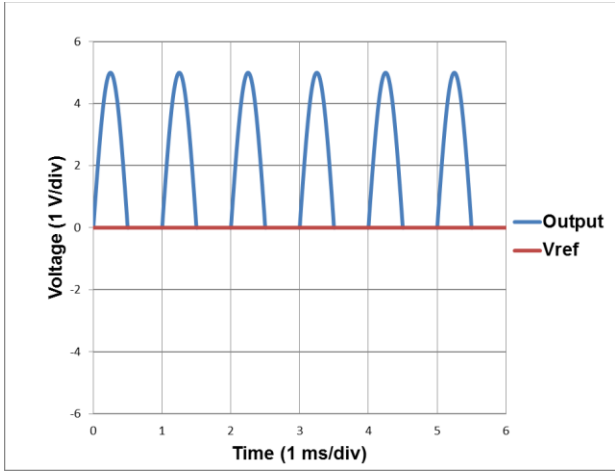

Figure 21. Single Direction Application Output Response

Application Information (continued)

Bidirectional Operation

The device is a bidirectional, current-sense amplifier capable of measuring currents through a resistive shunt in two directions. This bidirectional monitoring is common in applications that include charging and discharging operations where the current flow-through the shunt resistor can change directions.

The ability to measure this current flowing in both directions is enabled by applying a voltage to the REF pin, see Figure 22. The voltage applied to REF (V_{REF}) sets the output state that corresponds to the zero-input level state. The output then responds by increasing above V_{REF} for positive differential signals (relative to the IN- pin) and responds by decreasing below V_{REF} for negative differential signals. This reference voltage applied to the REF pin can be set anywhere between 0V to V_+ . For bidirectional applications, V_{REF} is typically set at mid-scale for equal signal range in both current directions. In some cases, however, V_{REF} is set at a voltage other than mid-scale when the bidirectional current and corresponding output signal do not need to be symmetrical. In Figure 22 the REF pin has been set to 2.5V therefore when the output of the ZXCT199Q is between zero and 2.5V, it represents a negative current through R_{SHUNT} . It is desirable to have an accurate low impedance voltage supply for the REF pin. A voltage reference, or a resistor divider buffered with an op-amp are recommended. Any error that is introduced at the REF pin is added to the output voltage. This error can be mitigated with differential inputs to an A to D converter discussed in the next section.

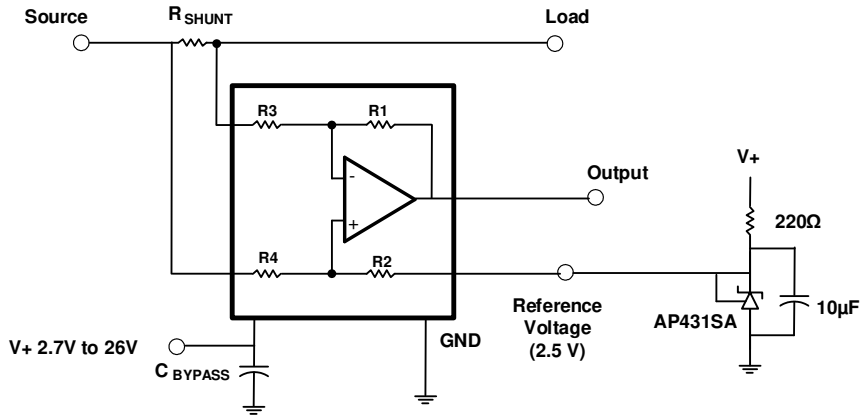

Figure 22. Bidirectional Application Schematic Using 2.5V Reference

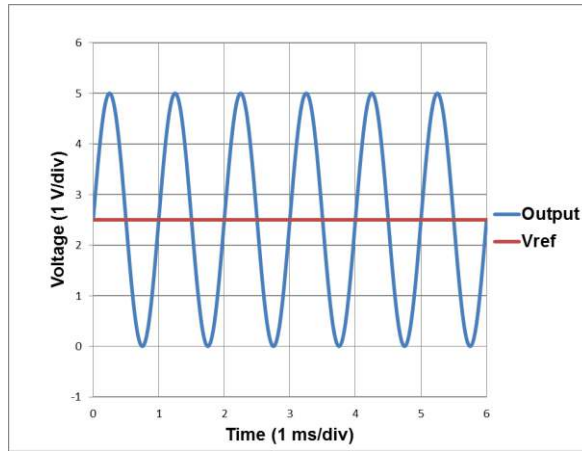

Figure 23. Bidirectional Application Output Response

Application Information (continued)

REF Input Impedance Effects and Improving Accuracy

As with any difference amplifier, the ZXCT199Q series common-mode rejection ratio is affected by any impedance present at the REF input. This concern is not a problem when the REF pin is connected directly to most references or power supplies. When using resistive dividers from the power supply or a reference voltage, the REF pin must be buffered by an operational amplifier.

In systems where the ZXCT199Q output can be sensed differentially, such as by a differential input analog-to-digital converter (ADC) or by using two separate ADC inputs, the effects of external impedance on the REF input can be cancelled. Figure 24 depicts a method of taking the output from the ZXCT199Q by using the REF pin as the differential reference.

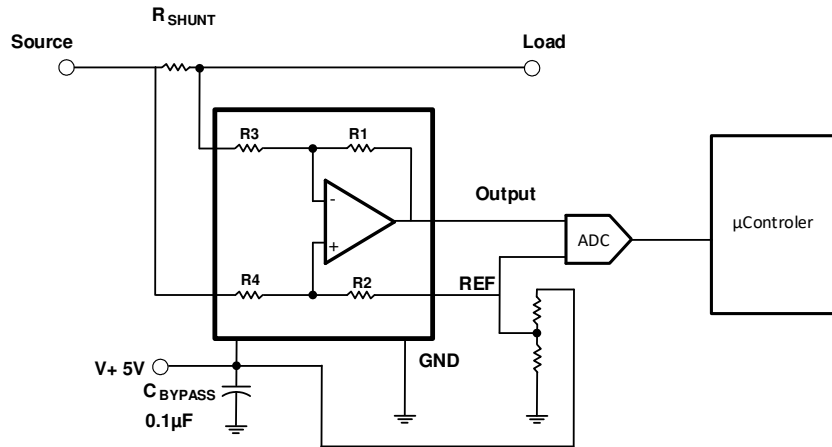

Figure 24. Differential Sensing of the ZXCT199Q to Cancel Effects of Impedance on the REF Input

The linear range of the output stage is limited in how close the output voltage can approach ground under zero input conditions. In single directional applications where measuring very low input currents at high accuracy (greater than 12 bits), set the REF pin to a convenient value above 150µV to get the output into the linear range of the device. This is needed to overcome the potential offset that may exist between the IN+ and IN- pins. If this type of offset were added to the application in Figure 19, the A to D converter and microprocessor could measure and store a zero current reading to be subtracted from subsequent readings making significant improvements to the accuracy of the low current readings.

In most cases, low current accuracy is not needed and the applications depicted in Figures 20 and 22 are adequate.

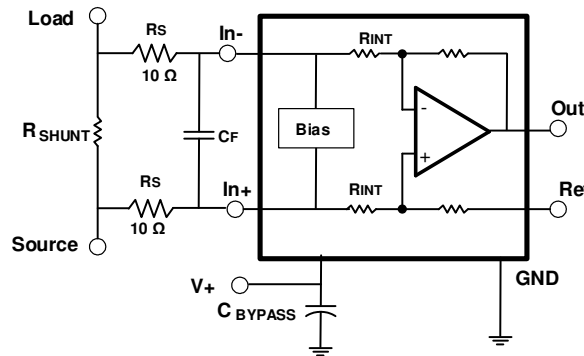

Figure 25. Filter at Input Pins

Application Information (continued)

Input Filtering

Input filtering may be needed to limit the bandwidth of signals or to add protection against transients that may be generated as the result of shunt inductance. If the added source resistors are not closely matched, there is an adverse impact on gain error, CMRR and V_{OS} . Figure 25 shows a filter placed at the inputs pins. It is recommended the added input resistors (R_S) should be 10Ω or less.

As a consideration to mitigate the impact of shunt inductance in a high current, high transient environment, the RC time constant of the added R_S and C_F should be greater than the time constant implied by the inductance and resistance implied by R_{SHUNT} .

$$2 \cdot R_S \cdot C_F \geq \frac{L_{SHUNT}}{R_{SHUNT}}$$

Due to additional current used in the bias circuit, the voltage between the IN- and IN+ pins will differ from voltage across the sense resistor. This will appear as a gain error at the output. These internal bias currents from the inputs are not equal in magnitude and change depending on common mode conditions. This is the motivation of keeping the added resistor below 10Ω . The table below has the equations for calculating the gain errors based on adding well matched source resistors. The equations include a provision for the additional $20\mu A$ current used by the bias circuit block that is depicted as bias in Figure 25.

| Product | Gain | R_{INT} | Gain Error | Gain Error % * | | |
|------------|------|-----------|--|------------------|------------------|--------------------|
| | | | Factor Equations | $R_S = 10\Omega$ | $R_S = 20\Omega$ | $R_S = 30.1\Omega$ |
| ZXCT199Qx1 | 50 | 20000 | $\frac{20,000}{(17 \cdot R_S) + 20,000}$ | 0.8428% | 1.6716% | 2.4947% |
| ZXCT199Qx2 | 100 | 10000 | $\frac{10,000}{(9 \cdot R_S) + 10,000}$ | 0.8920% | 1.7682% | 2.6375% |
| ZXCT199Qx3 | 200 | 5000 | $\frac{1,000}{R_S + 1000}$ | 0.9901% | 1.9608% | 2.9126% |

*The percentages shown should be rounded to 2 significant figures. The excess can be used to check calculations. This is for a typical semiconductor process.

$$Gain\ Error\ (\%) = 100 - (100 \cdot Gain\ Error\ Factor)$$

Where

R_{INT} is the internal resistors R3 and R4 used to set the gain and differs per device type.

R_S is the added input resistors.

Application Information (continued)

Using the ZXCT199Q with Common-Mode Transients above 30V

With a small amount of additional circuitry, the ZXCT199Q series can be used in circuits subject to transients higher than 30V, such as automotive applications. Use only Zener diode or Zener-type transient absorbers; any other type of transient absorber has an unacceptable time delay. Start by adding a pair of resistors (see Figure 26) as a working impedance for the Zener. Keeping these resistors as small as possible is preferable, most often approximately 10Ω. Larger values can be used with an effect on gain as discussed in the *Input Filtering* section. Because this circuit limits only short-term transients, many applications are satisfied with a 10Ω resistor along with conventional Zener diodes of the lowest power rating that can be found.

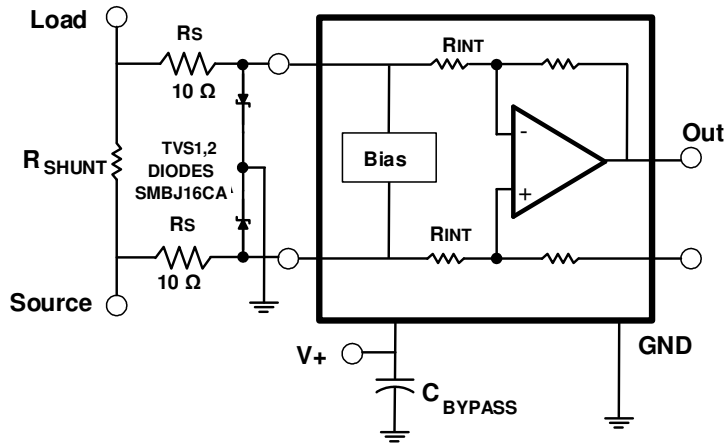

Figure 26. ZXCT199Q Transient Protection Using Dual TVS Diodes

The most package-efficient solution involves using a single absorber and back-to-back diodes between the device inputs. The most space-efficient solutions are dual series-connected diodes in a single SOT523 or SOD523 package. This method is shown in Figure 27. In either of these examples, the total board area required by the ZXCT199Q with all protective components is less than that of an SO-8 package, and only slightly greater than that of an MSOP-8 package.

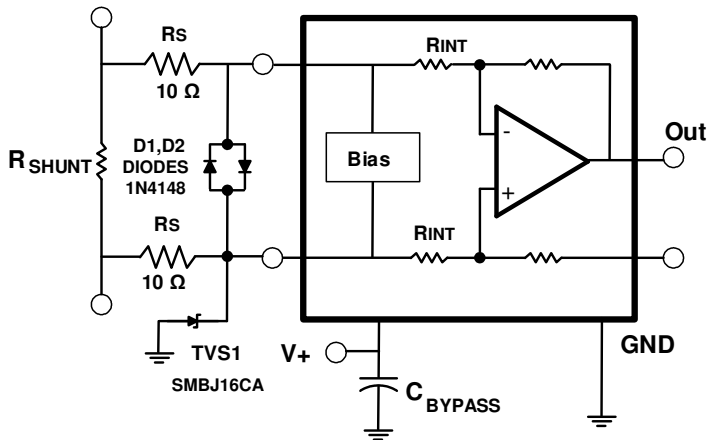

Figure 27. ZXCT199Q Transient Protection Using a Single TVS and Input Clamps

Application Information (continued)

Shutting Down the ZXCT199Q Series

Although the ZXCT199Q series does not have a shutdown pin, the low power consumption of the device allows the output of a logic gate or transistor switch to power the ZXCT199Q. This gate or switch turns on and turns off the ZXCT199Q power-supply quiescent current.

However, in current shunt monitoring applications, there is also a concern for how much current is drained from the shunt circuit in shutdown conditions. Evaluating this current drain involves considering the simplified schematic of the ZXCT199Q in shutdown mode shown in Figure 28.

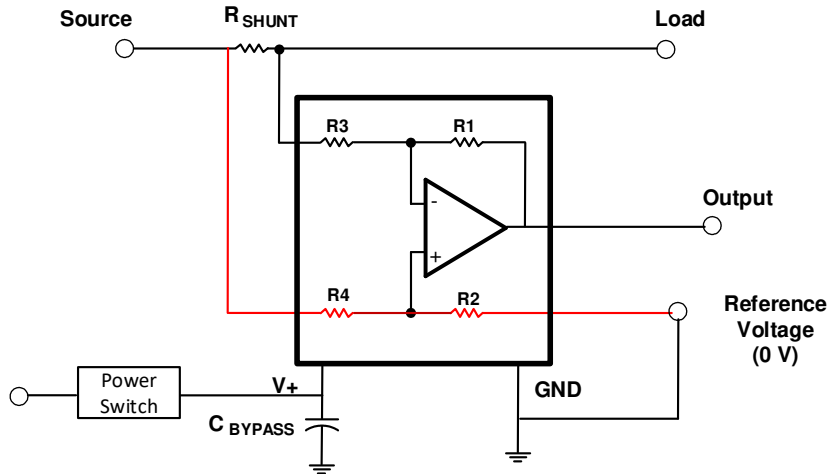
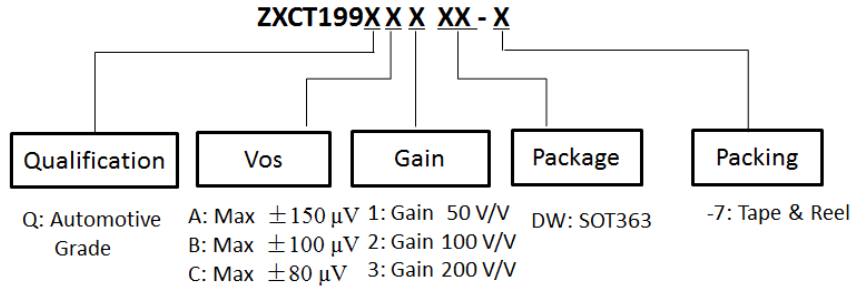

Figure 28. Basic Circuit for Shutting Down the ZXCT199Q with a Grounded Reference

There is typically slightly more than 1MΩ impedance (from the combination of 1MΩ feedback and 5kΩ input resistors) from each input of the ZXCT199Q to the OUT pin and to the REF pin. The amount of current flowing through these pins depends on the Source Voltage and the REF pin connection. For example, if the REF pin is grounded, the calculation of the effect of the 1MΩ impedance from the shunt to ground is straightforward. If the ZXCT199Q is powered down, the R3 and R1 path will not carry current unless there is a load on the output pin. The key point is that the R4 and R2 paths depicted in red are current paths, which may need some consideration in the very power sensitive applications. A provision to disconnect the REF pin may be needed.

Ordering Information



| Part Number | Part Number Suffix | Package Code | Package | Packing | |
|----------------|--------------------|--------------|---------|---------|-------------|
| | | | | Qty. | Carrier |
| ZXCT199QA1DW-7 | -7 | DW | SOT363 | 3000 | Tape & Reel |
| ZXCT199QA2DW-7 | -7 | DW | SOT363 | 3000 | Tape & Reel |
| ZXCT199QA3DW-7 | -7 | DW | SOT363 | 3000 | Tape & Reel |
| ZXCT199QB1DW-7 | -7 | DW | SOT363 | 3000 | Tape & Reel |
| ZXCT199QB2DW-7 | -7 | DW | SOT363 | 3000 | Tape & Reel |
| ZXCT199QB3DW-7 | -7 | DW | SOT363 | 3000 | Tape & Reel |
| ZXCT199QC1DW-7 | -7 | DW | SOT363 | 3000 | Tape & Reel |
| ZXCT199QC2DW-7 | -7 | DW | SOT363 | 3000 | Tape & Reel |
| ZXCT199QC3DW-7 | -7 | DW | SOT363 | 3000 | Tape & Reel |

Marking Information

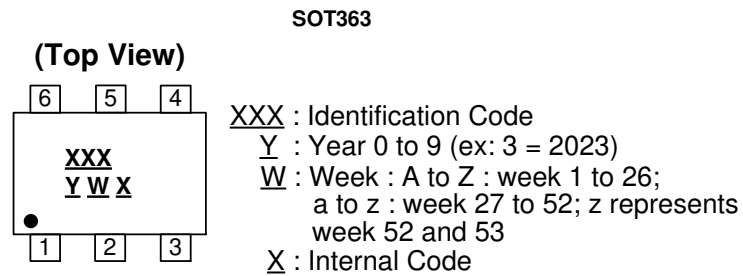

| Part Number | Package | Identification Code |
|----------------|---------|---------------------|
| ZXCT199QA1DW-7 | SOT363 | ZAQ |
| ZXCT199QA2DW-7 | SOT363 | ZBQ |
| ZXCT199QA3DW-7 | SOT363 | ZCQ |
| ZXCT199QB1DW-7 | SOT363 | ZKQ |
| ZXCT199QB2DW-7 | SOT363 | ZMQ |
| ZXCT199QB3DW-7 | SOT363 | ZNQ |
| ZXCT199QC1DW-7 | SOT363 | ZRQ |
| ZXCT199QC2DW-7 | SOT363 | ZSQ |
| ZXCT199QC3DW-7 | SOT363 | ZTQ |

Package Outline Dimensions

Please see <http://www.diodes.com/package-outlines.html> for the latest version.

SOT363

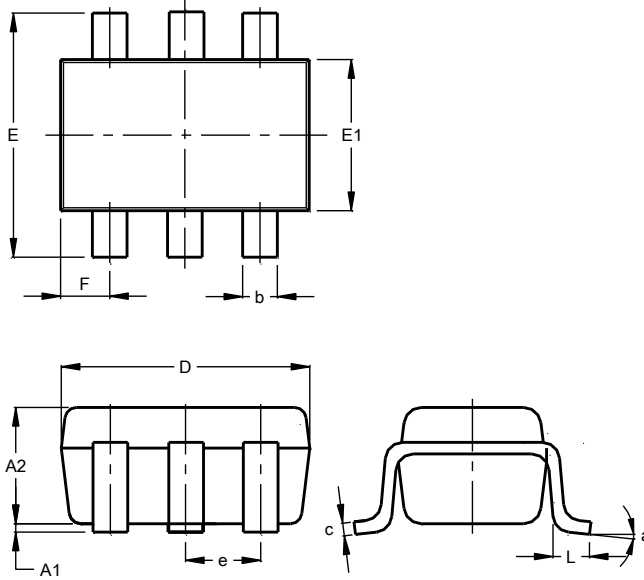

| SOT363 | | | |
|-----------------------------|-----------|------|-------|
| Dim | Min | Max | Typ |
| A1 | 0.00 | 0.10 | 0.05 |
| A2 | 0.90 | 1.00 | 0.95 |
| b | 0.10 | 0.30 | 0.25 |
| c | 0.10 | 0.22 | 0.11 |
| D | 1.80 | 2.20 | 2.15 |
| E | 2.00 | 2.20 | 2.10 |
| E1 | 1.15 | 1.35 | 1.30 |
| e | 0.650 BSC | | |
| F | 0.40 | 0.45 | 0.425 |
| L | 0.25 | 0.40 | 0.30 |
| a | 0° | 8° | -- |
| All Dimensions in mm | | | |

Suggested Pad Layout

Please see <http://www.diodes.com/package-outlines.html> for the latest version.

SOT363

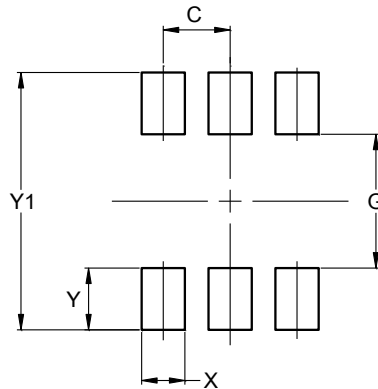

| Dimensions | Value (in mm) |
|------------|---------------|
| C | 0.650 |
| G | 1.300 |
| X | 0.420 |
| Y | 0.600 |
| Y1 | 2.500 |

Mechanical Data

- Moisture Sensitivity: Level 1 per J-STD-020
- Terminals: Finish – Matte Tin Plated Leads, Solderable per MIL-STD-202, Method 208 (e3)
- Weight: 0.006 grams (Approximate)
- Max Soldering Temperature +260°C for 30 secs as per JEDEC J-STD-020

IMPORTANT NOTICE

1. DIODES INCORPORATED (Diodes) AND ITS SUBSIDIARIES MAKE NO WARRANTY OF ANY KIND, EXPRESS OR IMPLIED, WITH REGARDS TO ANY INFORMATION CONTAINED IN THIS DOCUMENT, INCLUDING, BUT NOT LIMITED TO, THE IMPLIED WARRANTIES OF MERCHANTABILITY, FITNESS FOR A PARTICULAR PURPOSE OR NON-INFRINGEMENT OF THIRD PARTY INTELLECTUAL PROPERTY RIGHTS (AND THEIR EQUIVALENTS UNDER THE LAWS OF ANY JURISDICTION).
2. The Information contained herein is for informational purpose only and is provided only to illustrate the operation of Diodes' products described herein and application examples. Diodes does not assume any liability arising out of the application or use of this document or any product described herein. This document is intended for skilled and technically trained engineering customers and users who design with Diodes' products. Diodes' products may be used to facilitate safety-related applications; however, in all instances customers and users are responsible for (a) selecting the appropriate Diodes products for their applications, (b) evaluating the suitability of Diodes' products for their intended applications, (c) ensuring their applications, which incorporate Diodes' products, comply the applicable legal and regulatory requirements as well as safety and functional-safety related standards, and (d) ensuring they design with appropriate safeguards (including testing, validation, quality control techniques, redundancy, malfunction prevention, and appropriate treatment for aging degradation) to minimize the risks associated with their applications.
3. Diodes assumes no liability for any application-related information, support, assistance or feedback that may be provided by Diodes from time to time. Any customer or user of this document or products described herein will assume all risks and liabilities associated with such use, and will hold Diodes and all companies whose products are represented herein or on Diodes' websites, harmless against all damages and liabilities.
4. Products described herein may be covered by one or more United States, international or foreign patents and pending patent applications. Product names and markings noted herein may also be covered by one or more United States, international or foreign trademarks and trademark applications. Diodes does not convey any license under any of its intellectual property rights or the rights of any third parties (including third parties whose products and services may be described in this document or on Diodes' website) under this document.
5. Diodes' products are provided subject to Diodes' Standard Terms and Conditions of Sale (<https://www.diodes.com/about/company/terms-and-conditions/terms-and-conditions-of-sales/>) or other applicable terms. This document does not alter or expand the applicable warranties provided by Diodes. Diodes does not warrant or accept any liability whatsoever in respect of any products purchased through unauthorized sales channel.
6. Diodes' products and technology may not be used for or incorporated into any products or systems whose manufacture, use or sale is prohibited under any applicable laws and regulations. Should customers or users use Diodes' products in contravention of any applicable laws or regulations, or for any unintended or unauthorized application, customers and users will (a) be solely responsible for any damages, losses or penalties arising in connection therewith or as a result thereof, and (b) indemnify and hold Diodes and its representatives and agents harmless against any and all claims, damages, expenses, and attorney fees arising out of, directly or indirectly, any claim relating to any noncompliance with the applicable laws and regulations, as well as any unintended or unauthorized application.
7. While efforts have been made to ensure the information contained in this document is accurate, complete and current, it may contain technical inaccuracies, omissions and typographical errors. Diodes does not warrant that information contained in this document is error-free and Diodes is under no obligation to update or otherwise correct this information. Notwithstanding the foregoing, Diodes reserves the right to make modifications, enhancements, improvements, corrections or other changes without further notice to this document and any product described herein. This document is written in English but may be translated into multiple languages for reference. Only the English version of this document is the final and determinative format released by Diodes.
8. Any unauthorized copying, modification, distribution, transmission, display or other use of this document (or any portion hereof) is prohibited. Diodes assumes no responsibility for any losses incurred by the customers or users or any third parties arising from any such unauthorized use.
9. This Notice may be periodically updated with the most recent version available at <https://www.diodes.com/about/company/terms-and-conditions/important-notice>

The Diodes logo is a registered trademark of Diodes Incorporated in the United States and other countries.
All other trademarks are the property of their respective owners.
© 2023 Diodes Incorporated. All Rights Reserved.

www.diodes.com