



## NPN Power Silicon Transistor

*Qualified per MIL-PRF-19500/315*

*Qualified Levels:  
JAN, JANTX, and  
JANTXV*

### DESCRIPTION

This NPN silicon transistor is rated at 5 amps and is military qualified up to a JANTXV level. This TO-59 isolated package features a 180 degree lead orientation.

**Important:** For the latest information, visit our website <http://www.microsemi.com>.

### FEATURES

- JEDEC registered 2N2880
- Low saturation voltage
- Low leakage current
- Fast switching capable - 0.5  $\mu$ s rise time
- High frequency response
- TO-59 case with isolated terminals
- JAN, JANTX, and JANTXV, qualifications are available per MIL-PRF-19500/315
- RoHS compliant versions available (commercial grade only)



Marking may vary.

### TO-59 Package

### APPLICATIONS / BENEFITS

- Class 3B to ESD per MIL-STD-750 Method 1020
- High frequency inverters
- Converters
- Linear amplifiers
- High speed switching regulated power supplies
- RF power supplies

### MAXIMUM RATINGS

| Parameters/Test Conditions          | Symbol              | Value       | Unit          |
|-------------------------------------|---------------------|-------------|---------------|
| Junction and Storage Temperature    | $T_J$ and $T_{STG}$ | -65 to +200 | $^{\circ}C$   |
| Thermal Resistance Junction-to-Case | $R_{\theta JC}$     | 3.33        | $^{\circ}C/W$ |
| Collector Current                   | $I_C$               | 5.0         | A             |
| Collector-Emitter Voltage           | $V_{CEO}$           | 80          | V             |
| Collector-Base Voltage              | $V_{CBO}$           | 110         | V             |
| Emitter-Base Voltage                | $V_{EBO}$           | 8.0         | V             |
| Total Power Dissipation             | $P_T$               | 2.0         | W             |
|                                     |                     | 30          |               |

- Notes:**
1. Derate linearly 11.4 mW/ $^{\circ}C$  for  $T_A > +25^{\circ}C$ .
  2. Derate linearly 300 mW/ $^{\circ}C$  for  $T_C > +100^{\circ}C$ .

**MSC – Lawrence**  
6 Lake Street,  
Lawrence, MA 01841  
1-800-446-1158  
(978) 620-2600  
Fax: (978) 689-0803

**MSC – Ireland**  
Gort Road Business Park,  
Ennis, Co. Clare, Ireland  
Tel: +353 (0) 65 6840044  
Fax: +353 (0) 65 6822298

**Website:**  
[www.microsemi.com](http://www.microsemi.com)

**MECHANICAL and PACKAGING**

- CASE: Nickel Plated
- TERMINALS: Solder Dip over Nickel Plating. RoHS compliant Matte/Tin available on commercial grade only.
- MARKING: Manufacturer's ID, Date Code, Part Number, BeO
- POLARITY: See Package Outline Drawing on last page
- WEIGHT: Approximately 4.576 grams
- See [Package Dimensions](#) on last page.

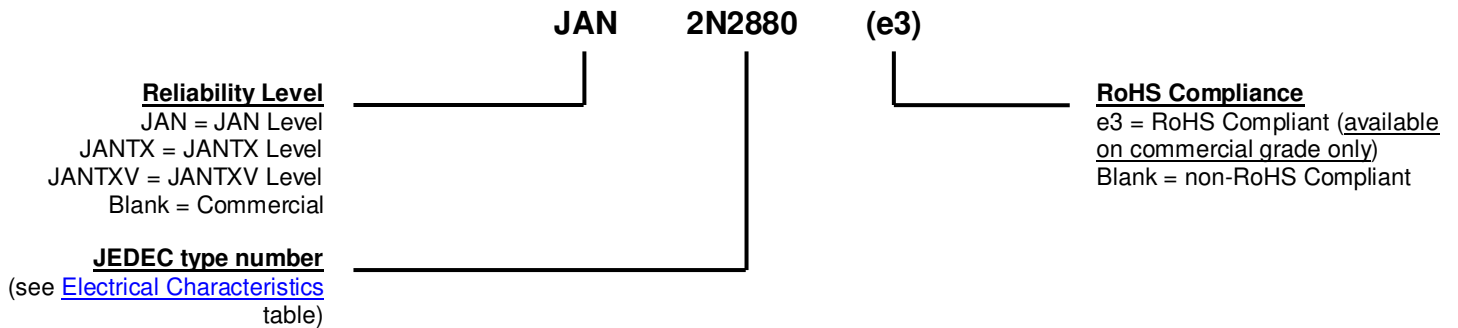
**PART NOMENCLATURE**

**SYMBOLS & DEFINITIONS**

| Symbol    | Definition  |
|-----------|---|
| $I_B$     | Base current: The value of the dc current into the base terminal.   |
| $I_C$     | Collector current: The value of the dc current into the collector terminal.   |
| $I_E$     | Emitter current: The value of the dc current into the emitter terminal.   |
| $P_T$     | Total power dissipation: The sum of the forward and reverse power dissipations.   |
| $V_{BE}$  | Base-emitter voltage: The dc voltage between the base and the emitter.  |
| $V_{CE}$  | Collector-emitter voltage: The dc voltage between the collector and the emitter.  |
| $V_{CEO}$ | Collector-emitter voltage, base open: The voltage between the collector and the emitter terminals when the base terminal is open-circuited. |
| $V_{CB}$  | Collector-base voltage: The dc voltage between the collector and the base.  |
| $V_{CBO}$ | Collector-base voltage, base open: The voltage between the collector and base terminals when the emitter terminal is open-circuited.        |
| $V_{EB}$  | Emitter-base voltage: The dc voltage between the emitter and the base   |
| $V_{EBO}$ | Emitter-base voltage, collector open: The voltage between the emitter and base terminals with the collector terminal open-circuited.        |

**ELECTRICAL CHARACTERISTICS @  $T_C = 25^\circ\text{C}$  unless otherwise noted**

| Characteristic | Symbol | Min. | Max. | Unit |
|----------------|--------|------|------|------|
|----------------|--------|------|------|------|

**OFF CHARACTERISTICS**

|  |               |     |     |               |
|--|---------------|-----|-----|---------------|
| Collector-Emitter Breakdown Voltage<br>$I_C = 100\text{ mA}$               | $V_{(BR)CEO}$ | 80  |     | V             |
| Collector-Emitter Breakdown Voltage<br>$I_C = 10\ \mu\text{A}$             | $V_{(BR)CBO}$ | 110 |     | V             |
| Emitter-Base Breakdown to Voltage<br>$I_E = 10\ \mu\text{A}$               | $V_{(BR)EBO}$ | 8.0 |     | V             |
| Collector-Emitter Cutoff Current<br>$V_{CE} = 60\text{ V}$                 | $I_{CEO}$     |     | 20  | $\mu\text{A}$ |
| Collector-Base Cutoff Current<br>$V_{CB} = 80\text{ V}$                    | $I_{CBO}$     |     | 0.2 | $\mu\text{A}$ |
| Collector-Emitter Cutoff Current<br>$V_{CE} = 110\text{ V}, V_{BE} = -0.5$ | $I_{CEX}$     |     | 1.0 | $\mu\text{A}$ |
| Emitter-Base Cutoff Current<br>$V_{EB} = 6.0\text{ V}$                     | $I_{EBO}$     |     | 0.2 | $\mu\text{A}$ |

**ON CHARACTERISTICS**

|   |               |                |             |   |
|---|---------------|----------------|-------------|---|
| Forward-Current Transfer Ratio<br>$I_C = 50\text{ mA}, V_{CE} = 5.0\text{ V}$<br>$I_C = 1.0\text{ A}, V_{CE} = 2.0\text{ V}$<br>$I_C = 5.0\text{ A}, V_{CE} = 5.0\text{ V}$ | $h_{FE}$      | 40<br>40<br>15 | 120<br>120  |   |
| Base-Emitter Voltage Non-saturated<br>$V_{CE} = 2.0\text{ V}, I_C = 1.0\text{ A}$   | $V_{BE}$      |                | 1.2         | V |
| Collector-Emitter Saturation Voltage<br>$I_C = 1.0\text{ A}, I_B = 0.1\text{ A}$<br>$I_C = 5.0\text{ A}, I_B = 0.5\text{ A}$  | $V_{CE(sat)}$ |                | 0.25<br>1.5 | V |
| Base-Emitter Saturation Voltage<br>$I_C = 1.0\text{ A}, I_B = 0.1\text{ A}$   | $V_{BE(sat)}$ |                | 1.2         | V |

**DYNAMIC CHARACTERISTICS**

|  |            |     |     |    |
|--|------------|-----|-----|----|
| Magnitude of Common Emitter Small-Signal Short-Circuit Forward Current Transfer Ratio<br>$I_C = 1.0\text{ A}, V_{CE} = 10.0\text{ V}, f = 10\text{ MHz}$ | $ h_{fe} $ | 3.0 | 12  |    |
| Common Emitter Small-Signal Short-Circuit Forward Current Transfer Ratio<br>$I_C = 50\text{ mA}, V_{CE} = 5.0\text{ V}, f = 1\text{ kHz}$                | $h_{fe}$   | 40  | 140 |    |
| Output Capacitance<br>$V_{CB} = 10\text{ V}, I_E = 0, 100 \leq f \leq 1.0\text{ MHz}$  | $C_{obo}$  |     | 150 | pF |

**SWITCHING CHARACTERISTICS**

|                    |       |  |     |               |
|--------------------|-------|--|-----|---------------|
| Pulse delay time   | $t_d$ |  | 60  | ns            |
| Pulse rise time    | $t_r$ |  | 300 | ns            |
| Pulse storage time | $t_s$ |  | 1.7 | $\mu\text{s}$ |
| Pulse fall time    | $t_f$ |  | 300 | ns            |

**ELECTRICAL CHARACTERISTICS @  $T_C = 25^\circ\text{C}$  unless otherwise noted. (continued)**
**SAFE OPERATING AREA (See Figure below and [MIL-STD-750, Test Method 3053](#))**
**DC Tests**
 $T_C = +100^\circ\text{C}$ ,  $t = 10$  seconds

**Test 1**
 $V_{CE} = 80$  V,  $I_C = 80$  mA

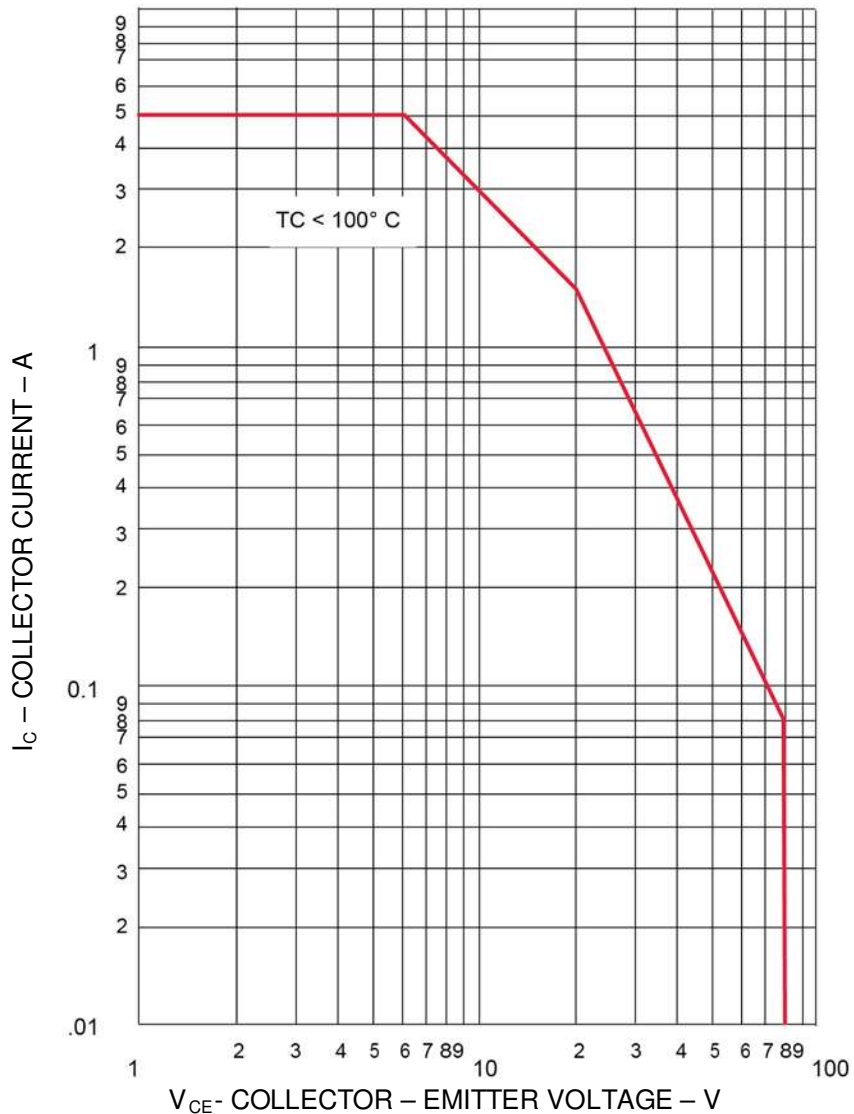
**Test 2**
 $V_{CE} = 20$  V,  $I_C = 1.5$  A

**FIGURE 1**  
Maximum Safe Operating Area

GRAPHS

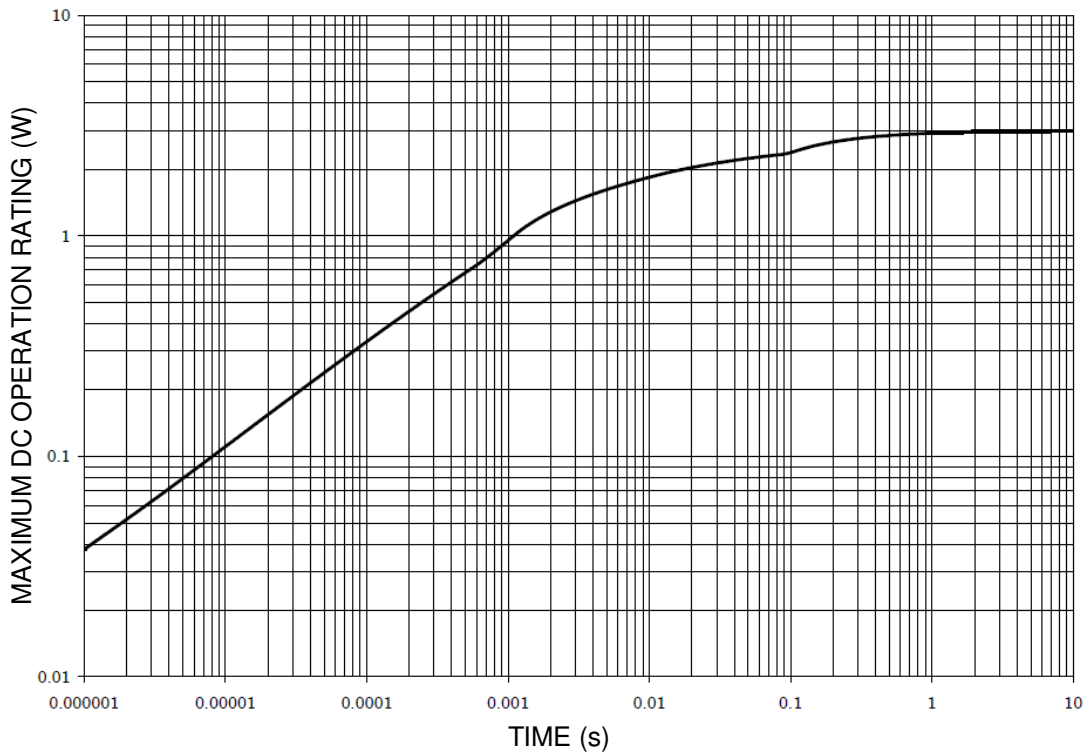

**FIGURE 2**  
Thermal Impedance

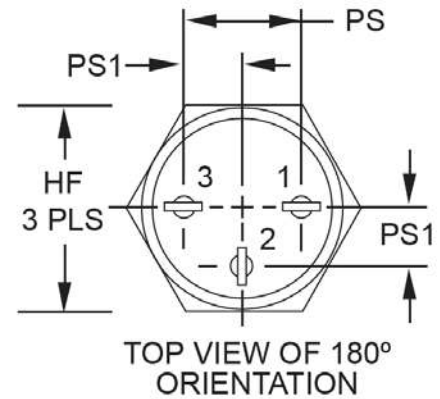
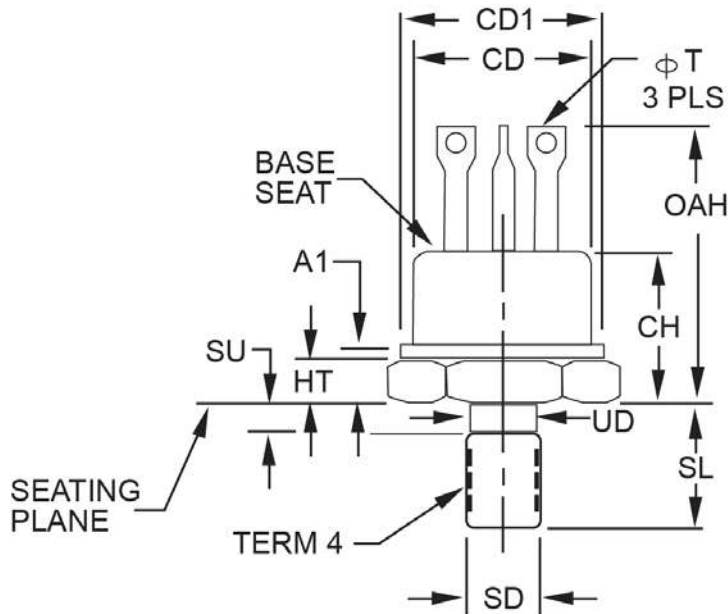
**PACKAGE DIMENSIONS**

**NOTES:**

1. Dimensions are in inches.
2. Millimeters are given for information only.
3. Collector shall be electrically connected to the case. This terminal may be flattened and pierced only when the 90 degree option is used.
4. SD is the outer diameter of coated threads. (Reference: Screw thread standards for Federal Standard H28/1, (FED-STD-H28/1).
5. The orientation of the terminals in relation to the hex flats is not controlled.
6. All three terminals.
7. The case temperature may be measured anywhere on the seating plane within .125 (3.18 mm) of the stud.
8. Terminal spacing measured at the base seat only.
9. Dimensions e, e1, PS1, and PS are measured from the center line of terminals.
10. Maximum unthreaded dimension.
11. This dimension applies to the location of the center line of the terminals.
12. A 90 degree angle lead orientation as shown may be used at the option of the manufacturer. All dimensions of the basic outline except e, e1, and the 120 degree lead angle apply to this option.

| Symbol | Dimension      |       |             |       | Notes   |
|--------|----------------|-------|-------------|-------|---------|
|        | Inch           |       | Millimeters |       |         |
|        | Min            | Max   | Min         | Max   |         |
| A1     | 0.090          | 0.150 | 2.29        | 3.81  |         |
| CD     | 0.320          | 0.468 | 8.13        | 11.89 |         |
| CD1    | 0.380          | 0.437 | 9.65        | 11.10 |         |
| CH     | 0.320          | 0.468 | 8.13        | 11.89 |         |
| HF     | 0.423          | 0.438 | 10.74       | 11.13 |         |
| HT     | -              | 0.250 | -           | 6.35  |         |
| OAH    | 0.570          | 0.763 | 14.48       | 19.38 | 4       |
| PS     | 0.185          | 0.215 | 4.70        | 5.46  | 5, 8, 9 |
| PS1    | 0.090          | 0.110 | 2.29        | 2.79  | 5, 8, 9 |
| SD     | 0.190-32UNF-2A |       |             |       | 4       |
| SL     | 0.400          | 0.455 | 10.16       | 11.56 |         |
| SU     | -              | 0.078 | -           | 1.98  | 10      |
| φT     | 0.040          | 0.065 | 1.02        | 1.65  |         |
| UD     | 0.155          | 0.189 | 3.94        | 4.80  |         |