

P/N # 0260	
MOLD NO. # 0260	
PIN	0260-G

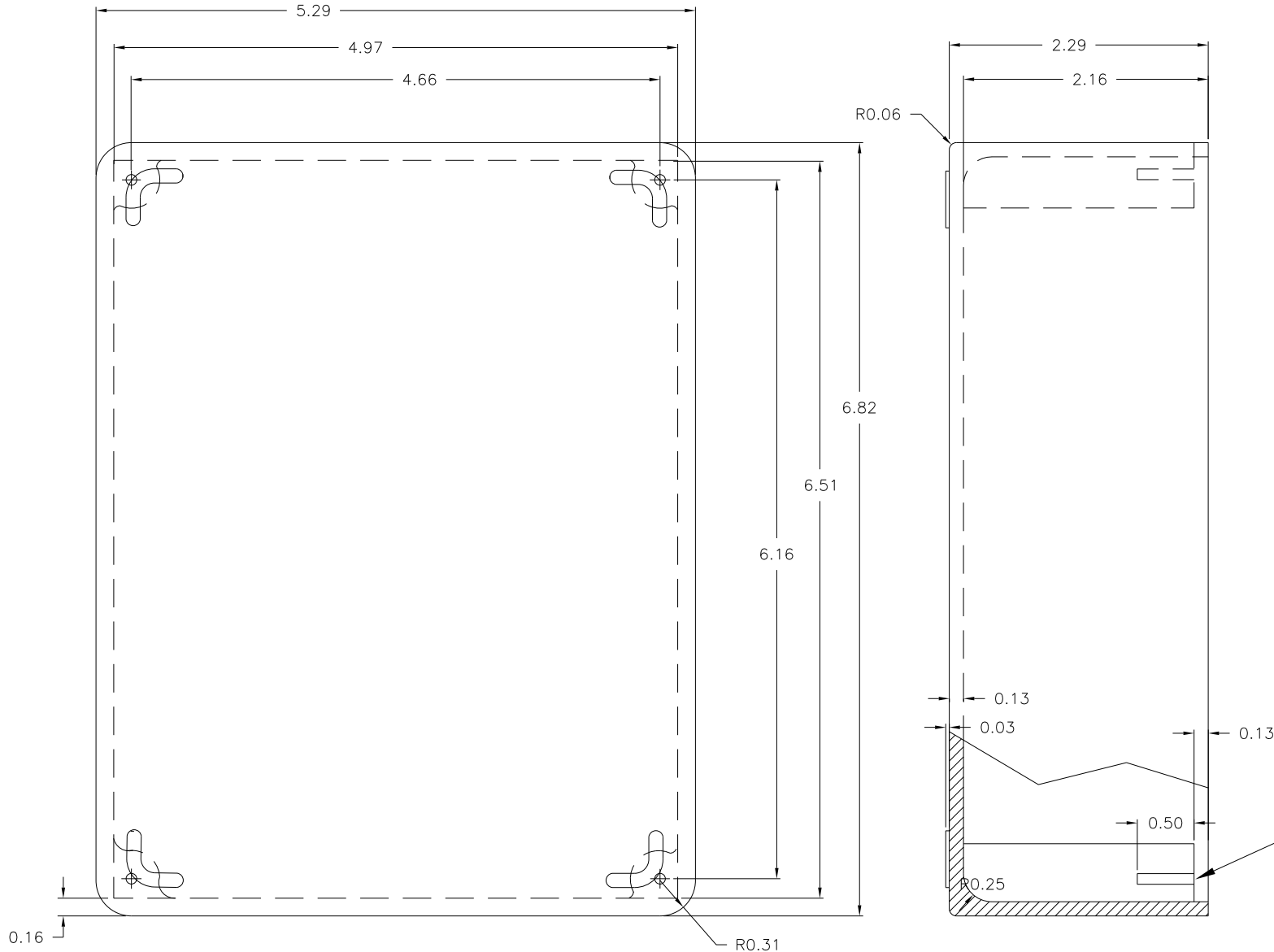

- NOTE(S) :
- (1) NO BLISTERS PERMITTED.
  - (2) NO BOWED OR WARPED CONDITIONS PERMITTED.
  - (3) ALL(4) CORNERS MUST BE ROUTED AT THE MOLDING PRESS.
  - (4) OPERATOR MUST USE COOLING FIXTURE DURING MOLDING PROCESS.

MATERIAL: #4311 PLENCO PHENOLIC (B41)  
 COLOR: BLACK

C H A N G E S			

TOLERANCES: UNLESS OTHERWISE SPECIFIED	DO NOT SCALE DRAWING
DECIMALS: X.XXX ± .005 X.XX ± .015	MM: X.XX ± 0.15MM X.X ± 0.4MM
FRACTIONS ± 1/64	ANG. ± 1°

DAVIES MOLDING Co. CAROL STREAM, IL	
DATE 8/8/52	MOLD No: 260
DRAWN BY JC	
APPROVED BY xxx	
SCALE FULL	SHEET 1 of 1