



# Transition Socket Specification

---

**Note the following details of the code protection feature on Microchip devices:**

- Microchip products meet the specification contained in their particular Microchip Data Sheet.
- Microchip believes that its family of products is one of the most secure families of its kind on the market today, when used in the intended manner and under normal conditions.
- There are dishonest and possibly illegal methods used to breach the code protection feature. All of these methods, to our knowledge, require using the Microchip products in a manner outside the operating specifications contained in Microchip's Data Sheets. Most likely, the person doing so is engaged in theft of intellectual property.
- Microchip is willing to work with the customer who is concerned about the integrity of their code.
- Neither Microchip nor any other semiconductor manufacturer can guarantee the security of their code. Code protection does not mean that we are guaranteeing the product as "unbreakable."

Code protection is constantly evolving. We at Microchip are committed to continuously improving the code protection features of our products. Attempts to break Microchip's code protection feature may be a violation of the Digital Millennium Copyright Act. If such acts allow unauthorized access to your software or other copyrighted work, you may have a right to sue for relief under that Act.

---

Information contained in this publication regarding device applications and the like is provided only for your convenience and may be superseded by updates. It is your responsibility to ensure that your application meets with your specifications. MICROCHIP MAKES NO REPRESENTATIONS OR WARRANTIES OF ANY KIND WHETHER EXPRESS OR IMPLIED, WRITTEN OR ORAL, STATUTORY OR OTHERWISE, RELATED TO THE INFORMATION, INCLUDING BUT NOT LIMITED TO ITS CONDITION, QUALITY, PERFORMANCE, MERCHANTABILITY OR FITNESS FOR PURPOSE. Microchip disclaims all liability arising from this information and its use. Use of Microchip devices in life support and/or safety applications is entirely at the buyer's risk, and the buyer agrees to defend, indemnify and hold harmless Microchip from any and all damages, claims, suits, or expenses resulting from such use. No licenses are conveyed, implicitly or otherwise, under any Microchip intellectual property rights.

**Trademarks**

The Microchip name and logo, the Microchip logo, dsPIC, KEELOQ, KEELOQ logo, MPLAB, PIC, PICmicro, PICSTART, PIC<sup>32</sup> logo, rPIC and UNI/O are registered trademarks of Microchip Technology Incorporated in the U.S.A. and other countries.


FilterLab, Hampshire, HI-TECH C, Linear Active Thermistor, MXDEV, MXLAB, SEEVAL and The Embedded Control Solutions Company are registered trademarks of Microchip Technology Incorporated in the U.S.A.

Analog-for-the-Digital Age, Application Maestro, CodeGuard, dsPICDEM, dsPICDEM.net, dsPICworks, dsSPEAK, ECAN, ECONOMONITOR, FanSense, HI-TIDE, In-Circuit Serial Programming, ICSP, Mindi, MiWi, MPASM, MPLAB Certified logo, MPLIB, MPLINK, mTouch, Octopus, Omniscient Code Generation, PICC, PICC-18, PICDEM, PICDEM.net, PICKit, PICtail, REAL ICE, rLAB, Select Mode, Total Endurance, TSHARC, UniWinDriver, WiperLock and ZENA are trademarks of Microchip Technology Incorporated in the U.S.A. and other countries.

SQTP is a service mark of Microchip Technology Incorporated in the U.S.A.

All other trademarks mentioned herein are property of their respective companies.

© 2010, Microchip Technology Incorporated, Printed in the U.S.A., All Rights Reserved.

 Printed on recycled paper.

ISBN: 978-1-60932-069-0

*Microchip received ISO/TS-16949:2002 certification for its worldwide headquarters, design and wafer fabrication facilities in Chandler and Tempe, Arizona; Gresham, Oregon and design centers in California and India. The Company's quality system processes and procedures are for its PIC<sup>®</sup> MCUs and dsPIC<sup>®</sup> DSCs, KEELOQ<sup>®</sup> code hopping devices, Serial EEPROMs, microperipherals, nonvolatile memory and analog products. In addition, Microchip's quality system for the design and manufacture of development systems is ISO 9001:2000 certified.*

**QUALITY MANAGEMENT SYSTEM  
CERTIFIED BY DNV  
== ISO/TS 16949:2002 ==**



---

---

## Transition Socket Specification

---

---

### INTRODUCTION

Transition sockets are products that allow header boards (for next generation in-circuit emulators or in-circuit debuggers) or device adapters (for the MPLAB ICE 2000 in-circuit emulator) to interface to sockets on target applications.

Typically, header boards or device adapters have connectors that match development cycle device formats, such as DIP or PLCC. However, target sockets will match compact production device formats, such as SOIC, SSOP, QFP, or QFN. The solution is transition sockets. A transition socket is specifically designed to provide compatibility between two differing types of IC package formats.

Transition sockets are typically composed of two parts: the adapter socket and the adapter header. The adapter socket is designed to plug into the header board or device adapter on one side, and the adapter header on the other. The adapter header is then soldered down to the target application.

### WHY SHOULD I USE TRANSITION SOCKETS IN MY PRODUCT DESIGN?

There are two very significant advantages to using transition sockets:

1. Shorter product development cycle
2. Reduced expense in the design, layout and prototype testing

A typical product design cycle has two important phases: the prototype design phase and the production design phase. Traditionally, these phases were different simply because the prototype used a microcontroller with a different package type. However, with the availability of the transition sockets, the prototype design can be identical to the production design because a transition socket can be used to bridge microcontroller package differences.

### WHAT TRANSITION SOCKETS ARE CURRENTLY AVAILABLE?

Microchip Technology currently offers the transition sockets listed in the "Table of Contents" following this introductory section.

Use the on-line Development Tools Selector (DTS) to find the transition sockets available for each header board or for each device adapter. For more on header boards or device adapters, see:

- *Header Board Specification (DS51292)*
- *MPLAB<sup>®</sup> ICE 2000 Processor Module and Device Adapter Specification (DS51140)*
- *MPLAB<sup>®</sup> ICE 4000 Processor Module and Device Adapter Specification (DS51298)*

Please see the Microchip web site ([www.microchip.com](http://www.microchip.com)) for the DTS and most current version of all documents.

### HOW CAN I OBTAIN MAXIMUM BENEFIT FROM THE USE OF TRANSITION SOCKETS?

Attention to component placement should be considered to provide adequate clearance for the transition socket interface to the PCB footprint. This is especially true for any tall components such as connector headers, radial components or voltage regulators. Refer to the transition socket mechanical drawings for dimensions.

# Transition Socket Specification

---

## TRANSITION SOCKET APPLICATIONS – COMMENTS AND SUGGESTIONS

Attention to component placement should be considered in mating the adapter sockets to the SOIC/SSOP headers.

The placement of vias around the Surface Mount Technology (SMT) layout area should be examined. Vias immediately adjacent to the end of a SMT pad may inadvertently come into contact with the header leads. Vias should be placed along the center line of the SMT pad to lessen the chance of pin-to-pin shorts while soldering.

Care should be taken when soldering some transition sockets to target boards. See the related section for specific instructions.

For information on packaging dimensions, please refer to the *Packaging Specification* (DS00049).

## GLOSSARY

Terms used in this document:

**DFN** – Dual Flat No lead

**DIP** – Dual In-line Package

**MQFP** – Metric Quad Flat Pack

**PDIP** – Plastic Dual In-line Package

**PLCC** – Plastic Leaded Chip Carrier

**QFN** – Quad Flat No lead

**QFP** – Quad Flat Pack

**SOIC** – Small Outline IC

**SOT** – Small Outline Transistor

**SSOP** – Shrink Small Outline Package

**TQFP** – Thin Quad Flat Pack




---



---

## Table of Contents

---



---

### Current Sockets

#### SOIC Transition Socket

---

|  |    |
|--|----|
| <b>XLT08SO-1</b>                         |    |
| 8-lead DIP to 8-lead SOIC .....          | 9  |
| <b>XLT08SN-1</b>                         |    |
| 8-lead DIP to 8-lead SOIC (Narrow) ..... | 10 |
| <b>XLT14SO-1</b>                         |    |
| 14-lead DIP to 14-lead SOIC .....        | 10 |
| <b>XLT18SO-1</b>                         |    |
| 18-lead DIP to 18-lead SOIC .....        | 11 |
| <b>XLT20SO1-1</b>                        |    |
| 20-lead DIP to 20-lead SOIC .....        | 11 |
| <b>XLT28SO-1</b>                         |    |
| 28-lead DIP to 28-lead SOIC .....        | 12 |

#### SSOP Transition Socket

---

|   |    |
|---|----|
| <b>XLT14SS-1</b>                                |    |
| 14-lead DIP to 14-lead SSOP .....               | 13 |
| <b>XLT20SS-1</b>                                |    |
| 18-lead DIP to 20-lead SSOP .....               | 14 |
| <b>XLT20SS1-1</b>                               |    |
| 20-lead DIP to 20-lead SSOP .....               | 14 |
| <b>XLT28SS-1</b>                                |    |
| 28-lead DIP to 28-lead SSOP .....               | 15 |
| <b>XLT28SS2-1</b>                               |    |
| 28-lead DIP to 28-lead SSOP (PIC16X55/57) ..... | 15 |

#### PLCC Transition Socket

---

|                             |    |
|-----------------------------|----|
| <b>XLT44L2</b>              |    |
| 44-lead PLCC (0.050") ..... | 16 |

#### QFP Transition Socket

---

|                               |    |
|-------------------------------|----|
| <b>XLT44PT3</b>               |    |
| 44-lead QFP (0.8 mm) .....    | 18 |
| <b>XLT64PT5, XLT80PT3</b>     |    |
| 64/80-lead QFP (0.5 mm) ..... | 18 |
| <b>XLT80PT2</b>               |    |
| 80-lead QFP (0.65 mm) .....   | 19 |

#### SOT/DFN/QFN Transition Sockets

---

|                                    |    |
|------------------------------------|----|
| <b>XLT06SOT</b>                    |    |
| 14-lead DIP to 6-lead SOT-23 ..... | 22 |
| <b>XLT08DFN2</b>                   |    |
| 14-lead DIP to 8-lead DFN .....    | 22 |

# Transition Socket Specification

---

|  |    |
|--|----|
| <b>XLT16QFN1, XLT28QFN3, XLT28QFN4, XLT44QFN2, XLT44QFN3, XLT44QFN4, XLT44QFN5</b> |    |
| Multi-lead DIP to Multi-lead QFN, Top View .....                                   | 23 |
| Multi-lead DIP to Multi-lead QFN, Side View .....                                  | 23 |
| Multi-lead DIP to Multi-lead QFN Cables .....                                      | 23 |
| <b>XLT20QFN-1</b>  |    |
| 20-lead DIP Adapter Socket .....   | 24 |
| 20-lead QFN Header (Surface Foot) .....  | 24 |
| XLT20QFN-1 Soldering Suggestions .....   | 25 |

# Transition Socket Specification

---

---

## Discontinued Sockets

### PDIP Transition Socket

---

#### **XLT28XP (Discontinued)**

28-lead DIP 0.300-inch Male to 0.600-inch Female ..... 26

### SOIC Transition Socket

---

#### **XLT08SO (Discontinued – see XLT08SO-1 or XLT08SN-1)**

8-lead DIP to 0.050-inch Adapter Socket ..... 27

8-lead SOIC Header ..... 27

#### **XLT14SO (Discontinued – see XLT14SO-1)**

14-lead DIP to 0.050-inch Adapter Socket ..... 28

14-lead SOIC Header ..... 28

#### **XLT18SO (Discontinued – see XLT18SO-1)**

18-lead DIP to 0.050-inch Adapter Socket ..... 28

18-lead SOIC Header ..... 28

#### **XLT20SO1 (Discontinued – see XLT20SO1-1)**

20-lead DIP to 0.050-inch Adapter Socket ..... 29

20-lead SOIC Header ..... 29

#### **XLT28SO (Discontinued – see XLT28SO-1)**

28-lead DIP to 0.050-inch Adapter Socket ..... 29

28-lead SOIC Header ..... 29

### SSOP Transition Socket

---

#### **XLT14SS (Discontinued – see XLT14SS-1)**

14-lead DIP to 0.8 mm Adapter Socket ..... 30

14-lead SSOP Header ..... 30

#### **XLT20SS (Discontinued – see XLT20SS-1)**

18-lead DIP to 0.8 mm Adapter Socket ..... 31

20-lead SSOP Header ..... 31

#### **XLT20SS1 (Discontinued – see XLT20SS1-1)**

20-lead DIP to 0.8 mm Adapter Socket ..... 31

20-lead SSOP Header ..... 31

#### **XLT28SS (Discontinued – see XLT28SS-1)**

#### **XLT28SS2 (Discontinued – see XLT28SS2-1)**

28-lead DIP to 0.8 mm Adapter Socket ..... 32

28-lead SSOP Header ..... 32

### PLCC Transition Socket

---

#### **XLT68L1, XLT84L1 (Discontinued)**

68/84-lead Adapter Socket ..... 34

### QFP Transition Socket

---

#### **XLT44PT (Discontinued – see XLT44PT3)**

44-lead QFP to 0.8 mm Adapter Socket ..... 35

#### **XLT64PT1 (Discontinued)**

#### **XLT64PT2 (Discontinued – see XLT64PT5)**

#### **XLT80PT (Discontinued – see XLT80PT3)**

64/80-lead QFP to 0.5 mm Adapter Socket ..... 36

#### **XLT64PT3 (Discontinued – see XLT64PT5)**

64-lead QFP to 0.8mm Adapter Socket ..... 36

#### **XLT64PT4 (Discontinued – see XLT64PT5)**

64-lead QFP (0.8 mm) ..... 37

# Transition Socket Specification

---

---

## SOT/DFN/QFN Transition Sockets

---

|   |    |
|---|----|
| <b>XLT08DFN (Discontinued – see XLT08DFN2)</b>  |    |
| 8-lead DIP to 0.025-inch Adapter Socket .....   | 39 |
| <b>XLT28QFN (Discontinued – see XLT28QFN4)</b>  |    |
| 28-lead DIP to 0.025-inch Adapter Socket .....  | 39 |
| <b>XLT28QFN2 (Discontinued – see XLT28QFN3)</b> |    |
| 18-lead DIP to 0.025-inch Adapter Socket .....  | 40 |
| <b>XLT44QFN (Discontinued – see XLT44QFN2)</b>  |    |
| 40-lead DIP to 0.025-inch Adapter Socket .....  | 40 |
| 44-lead QFN Header .....                        | 40 |



# Transition Socket Specification

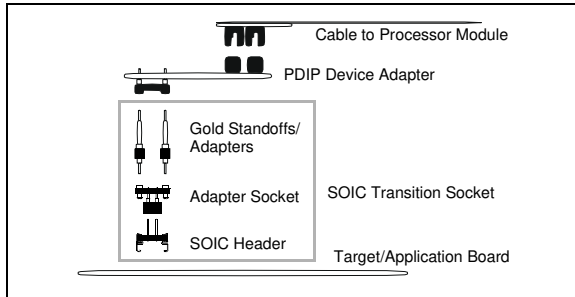
## CURRENT SOCKETS

The transition sockets in this section are currently available from Microchip.

## SOIC TRANSITION SOCKET

An SOIC transition socket and associated hardware is shown in Figure 1.

**FIGURE 1: SOIC TRANSITION SOCKET**



There are two components of the SOIC transition socket::

1. Adapter socket that connects to the DIP device adapter
2. SOIC header that is to be soldered down to the target application

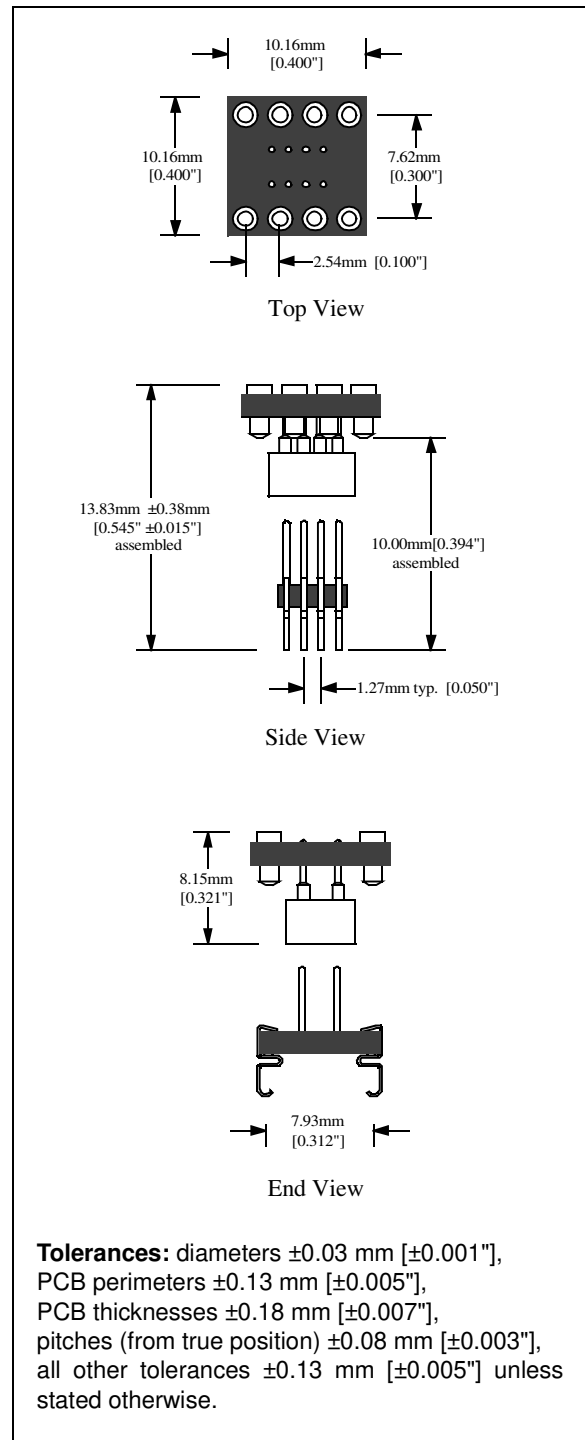
Microchip offers the following SOIC transition sockets:

- XLT08SO-1: One 8-lead DIP adapter socket and one 8-lead SOIC header (5.28mm body size)
- XLT08SN-1: One 8-lead DIP adapter socket and one 8-lead SOIC header (3.9mm body size)
- XLT14SO-1: One 14-lead DIP adapter socket and one 14-lead SOIC header
- XLT18SO-1: One 18-lead DIP adapter socket and one 18-lead SOIC header
- XLT20SO1-1: One 20-lead DIP adapter socket and one 20-lead SOIC header
- XLT28SO-1: One 28-lead DIP adapter socket and one 28-lead SOIC header

See the drawings in this section for layout dimensions.

## XLT08SO-1

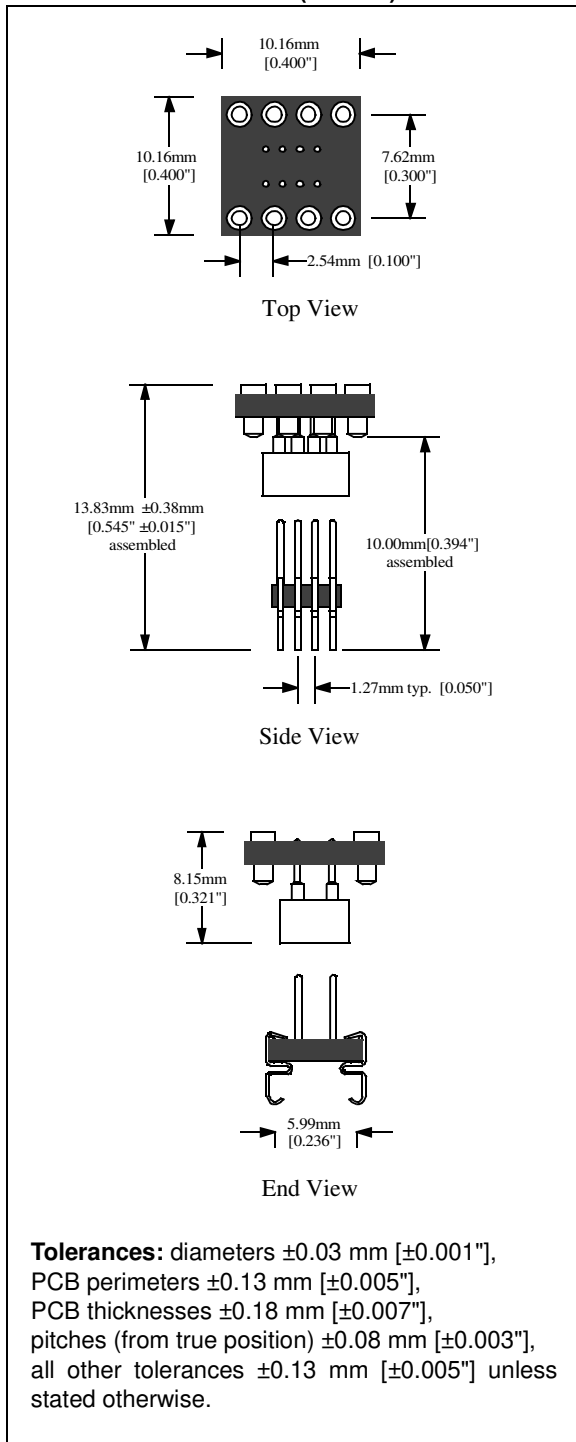
### 8-lead DIP to 8-lead SOIC



# Transition Socket Specification

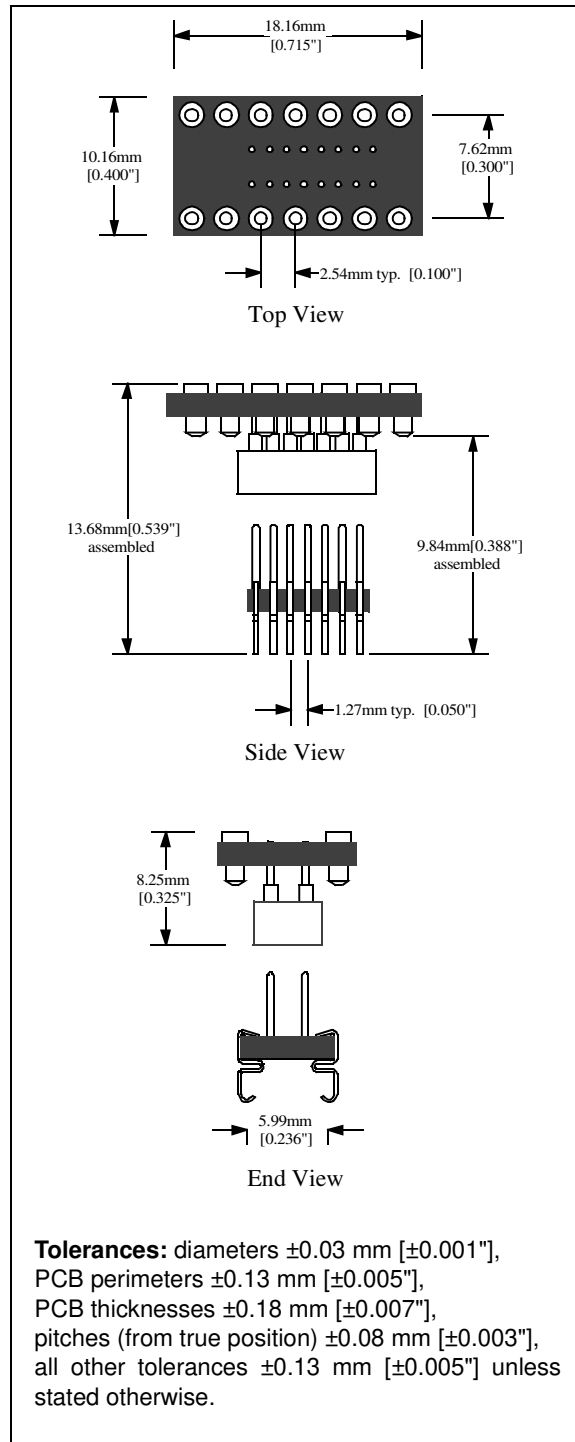
## XLT08SN-1

### 8-lead DIP to 8-lead SOIC (Narrow)



## XLT14SO-1

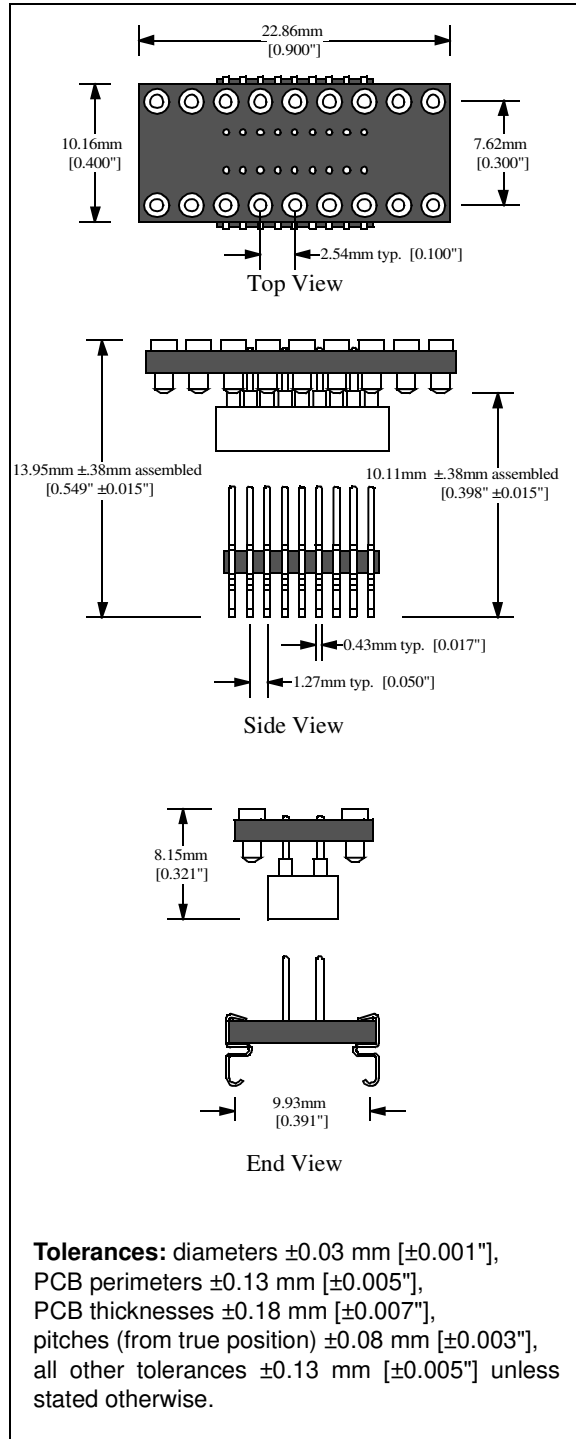
### 14-lead DIP to 14-lead SOIC



# Transition Socket Specification

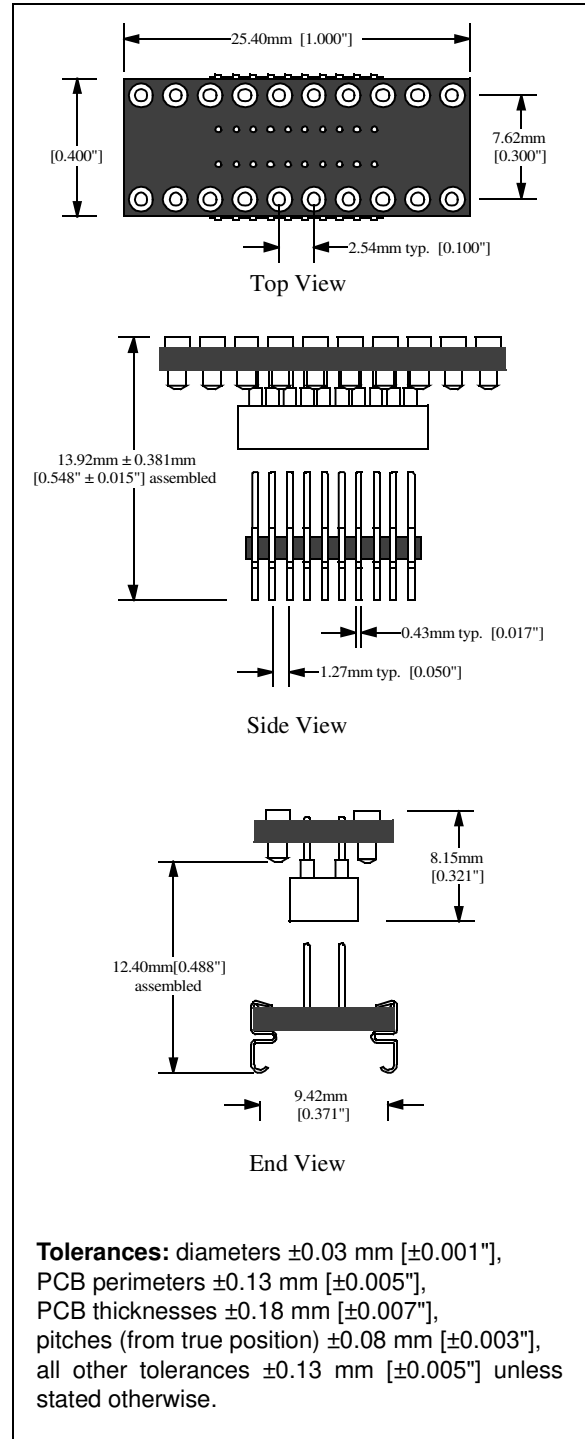
## XLT18SO-1

### 18-lead DIP to 18-lead SOIC



## XLT20SO1-1

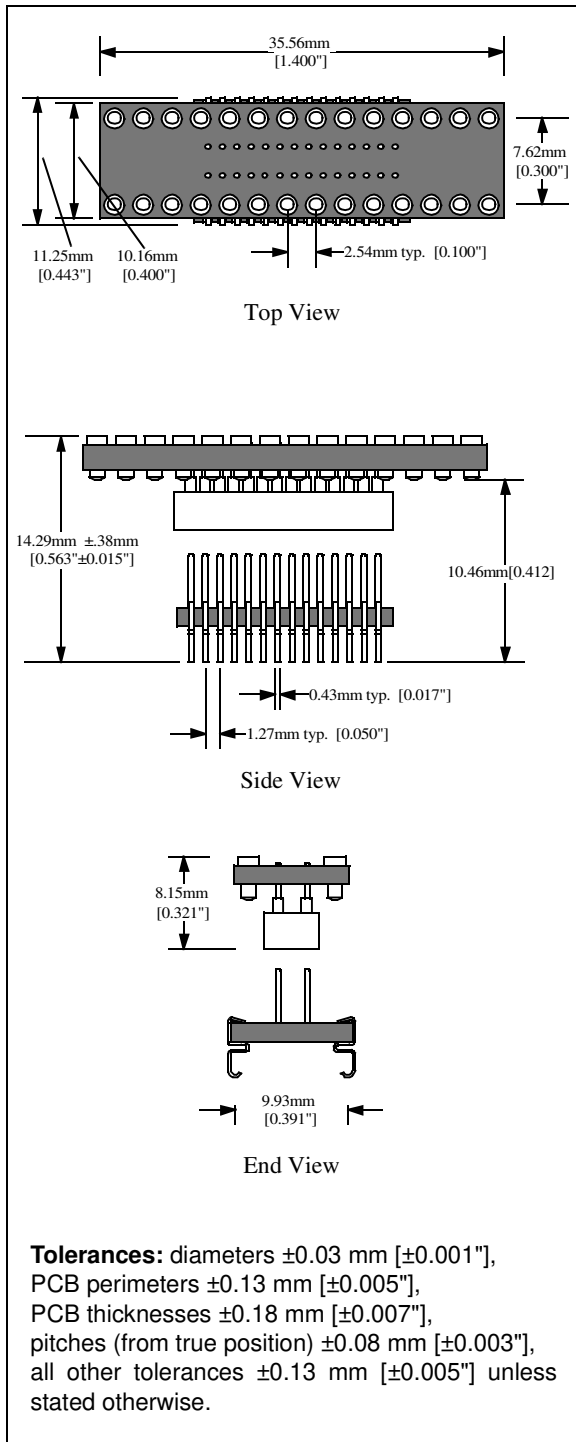
### 20-lead DIP to 20-lead SOIC



# Transition Socket Specification

## XLT28SO-1

### 28-lead DIP to 28-lead SOIC

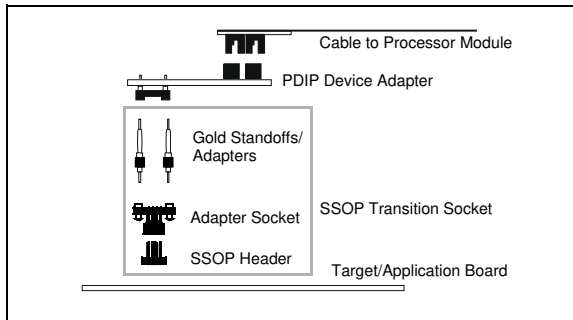


# Transition Socket Specification

## SSOP TRANSITION SOCKET

An SSOP transition socket and associated hardware is shown in Figure 2.

**FIGURE 2: SSOP TRANSITION SOCKET**



The SSOP transition sockets are similar to the SOIC transition sockets. There are two parts to the SSOP transition socket:

1. Adapter socket that connects to the DIP device adapter.
2. SSOP header that gets soldered down to the target application.

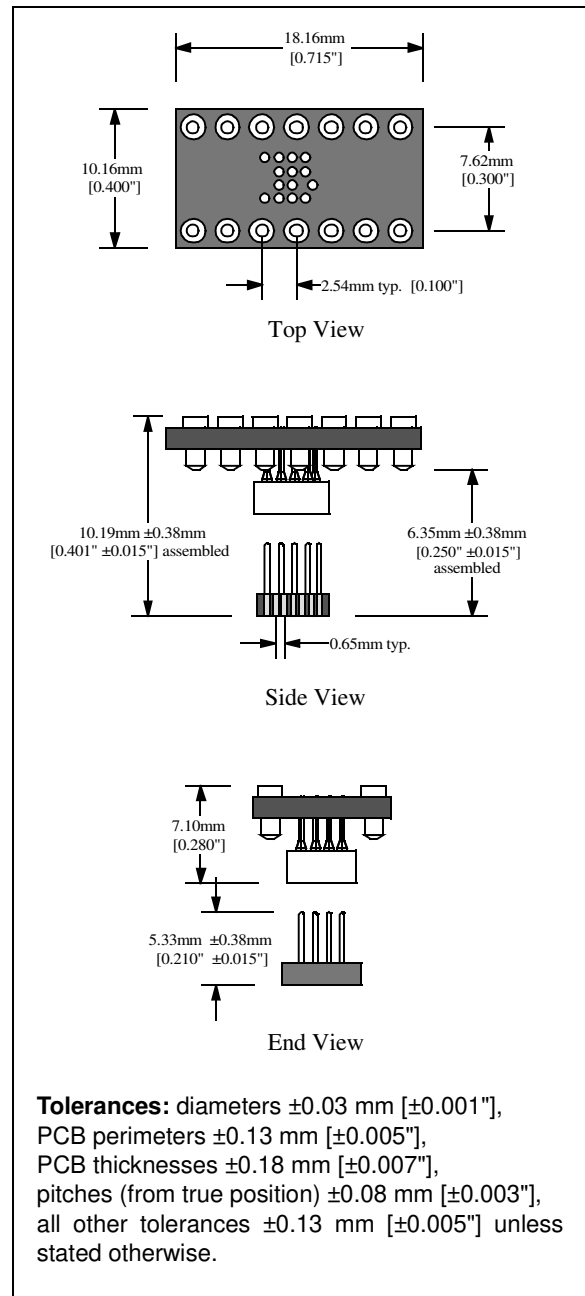
Microchip offers the following SSOP transition sockets:

- XLT14SS-1: One 14-lead DIP adapter socket and one 14-lead SSOP header
- XLT20SS-1: One 18-lead DIP adapter socket and one 20-lead SSOP header
- XLT20SS1-1: One 20-lead DIP adapter socket and one 20-lead SSOP header
- XLT28SS-1: One 28-lead DIP adapter socket and one 28-lead SSOP header
- XLT28SS2-1: One 28-lead DIP adapter socket and one 28-lead SSOP header (PIC16X55/57)

See the drawings in this section for layout dimensions and clearances for tall components.

## XLT14SS-1

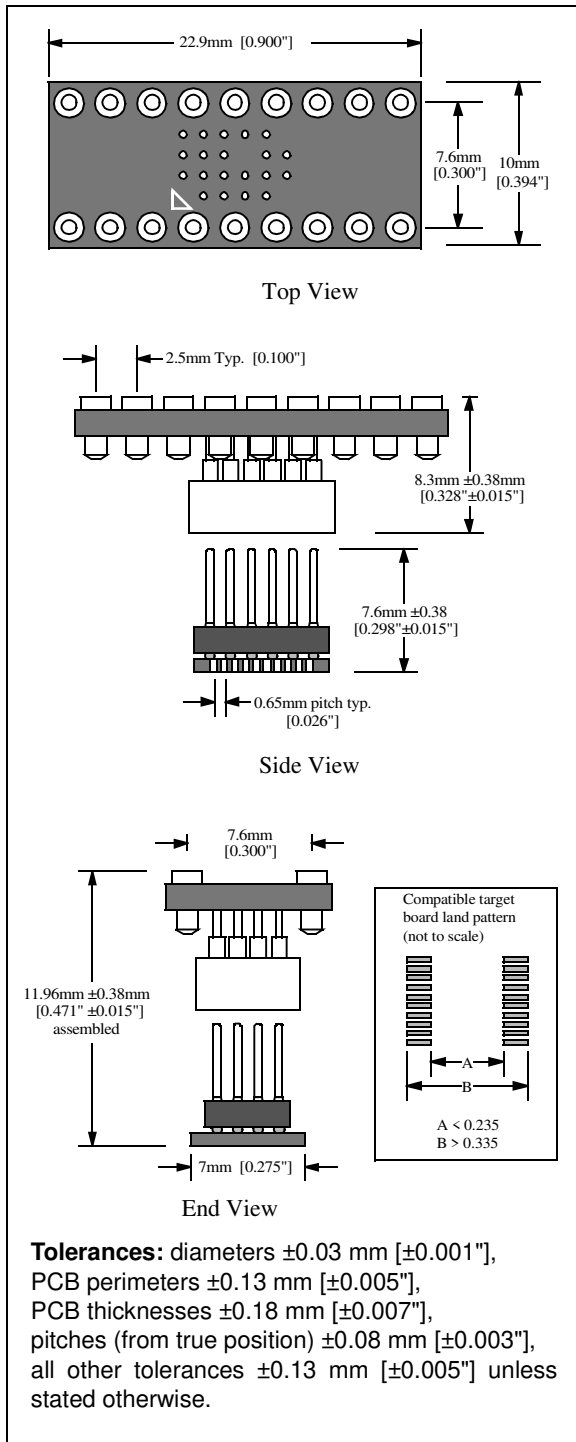
### 14-lead DIP to 14-lead SSOP



# Transition Socket Specification

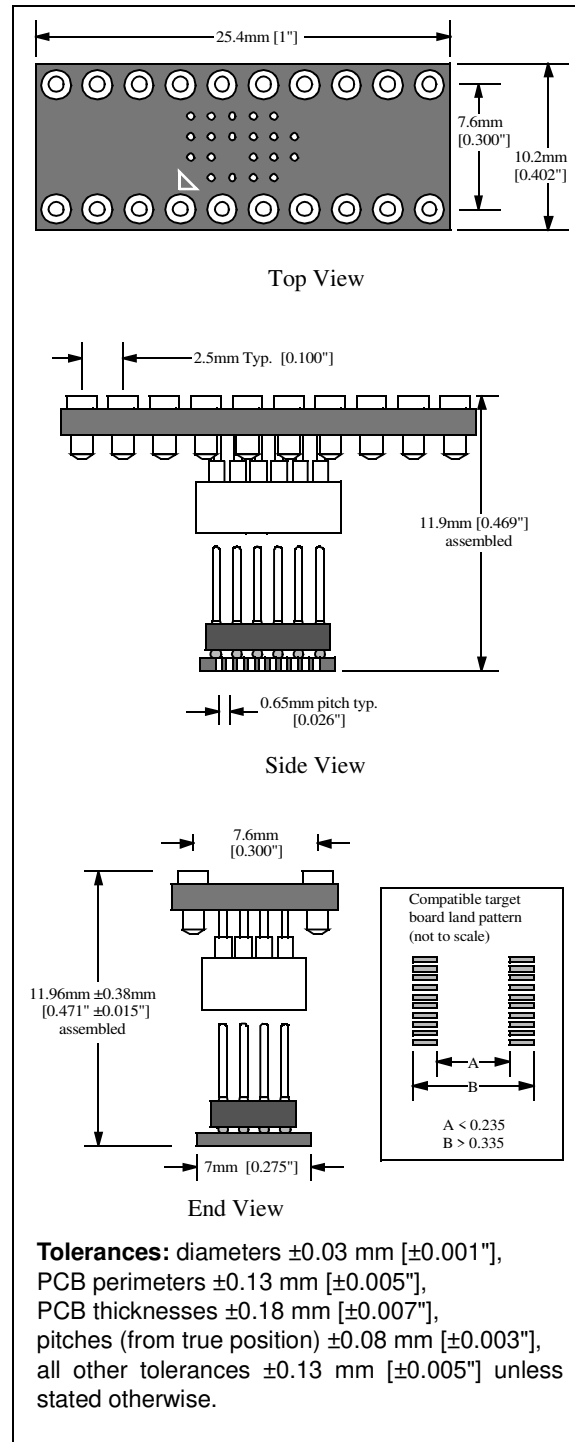
## XLT20SS-1

### 18-lead DIP to 20-lead SSOP



## XLT20SS1-1

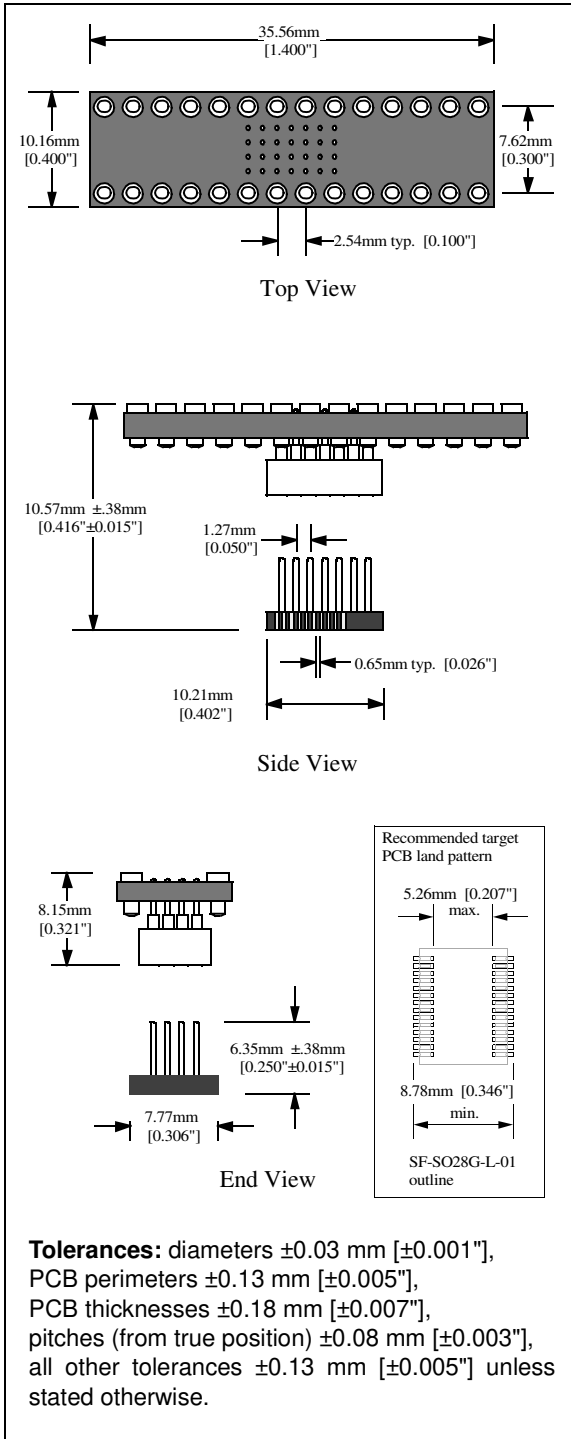
### 20-lead DIP to 20-lead SSOP



# Transition Socket Specification

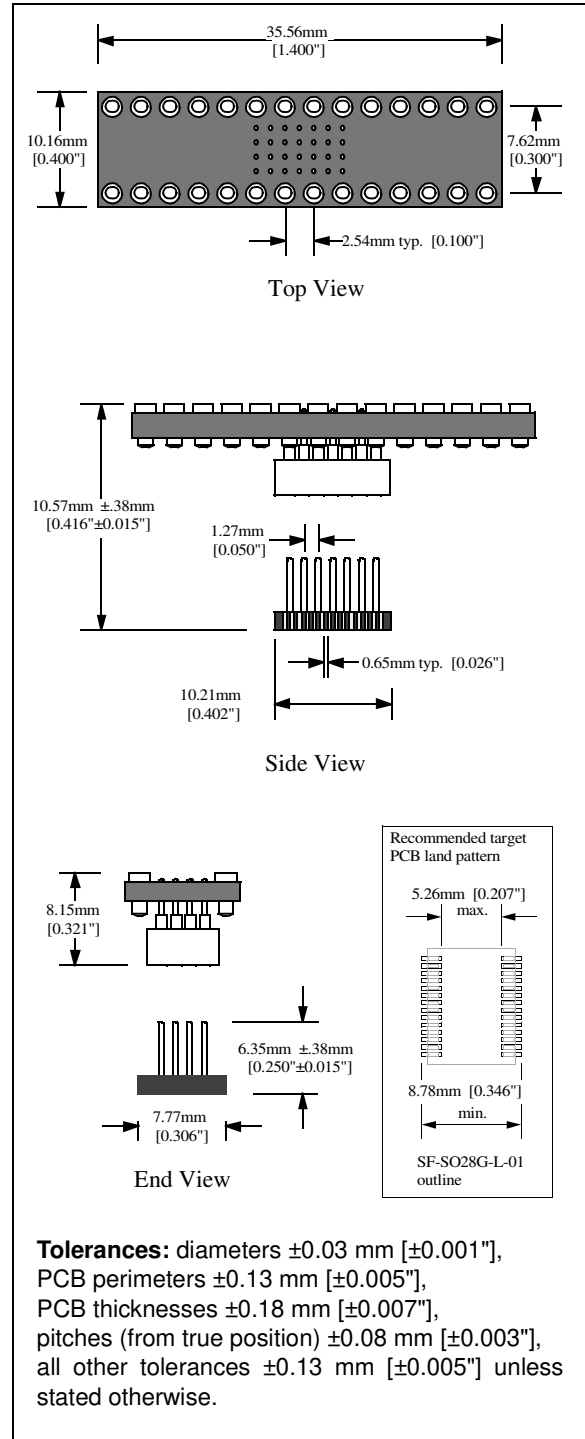
## XLT28SS-1

### 28-lead DIP to 28-lead SSOP



## XLT28SS2-1

### 28-lead DIP to 28-lead SSOP (PIC16X55/57)

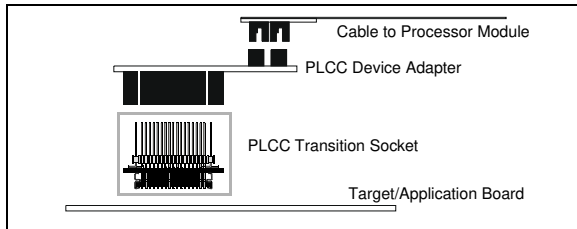


# Transition Socket Specification

## PLCC TRANSITION SOCKET

A PLCC transition socket and associated hardware is shown in Figure 3.

**FIGURE 3: PLCC TRANSITION SOCKET**



The PLCC transition socket is required for use along with the PLCC device adapters. The DAF18-1 device adapter is equipped with eight socket strips that interface with one of two transition sockets. The DAF18-3 device adapter is equipped with four socket strips that interface with one transition socket.

The PLCC transition sockets are designed with a threaded insert in the center of the footprint so that a 4/40 screw can securely fasten the transition socket to the device adapter.

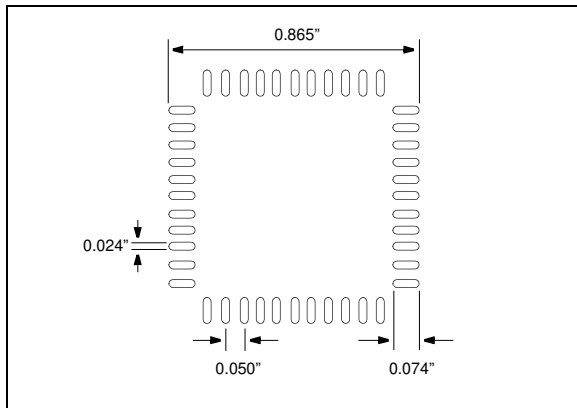
The PLCC transition sockets are designed to be soldered to the target PCB PLCC surface mount pattern or inserted into a PLCC socket on the target PCB.

**Note:** To avoid solder bridging, do not place vias within 0.025-inch of the PLCC footprint. Also, any vias near the PLCC should be directly on the centerline of the pad.

Microchip offers the following PLCC transition sockets:

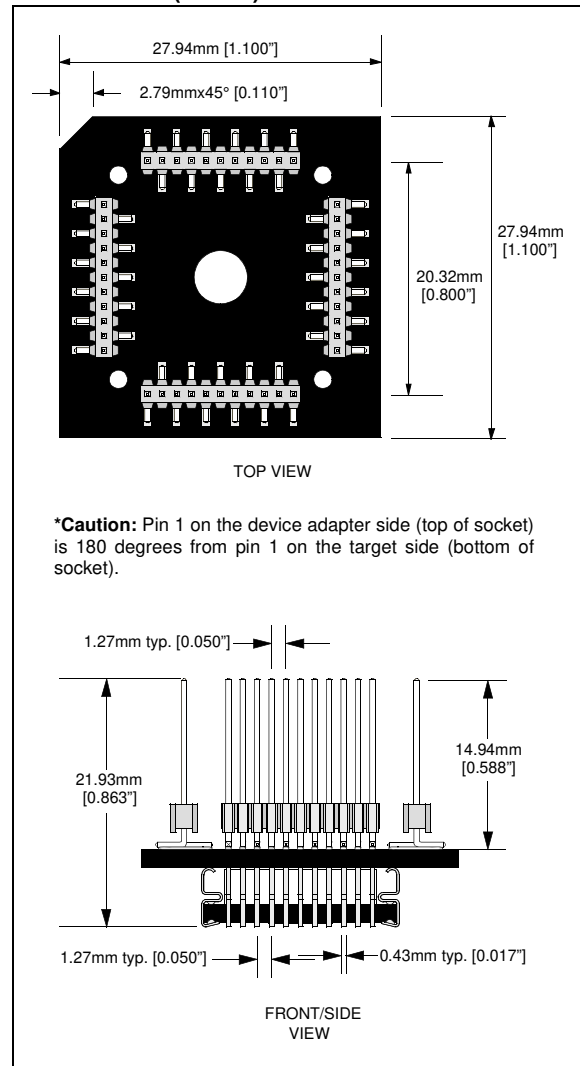
- XLT44L2: One 44-lead PLCC transition socket

## RECOMMENDED PCB LAYOUT



## XLT44L2

### 44-lead PLCC (0.050")



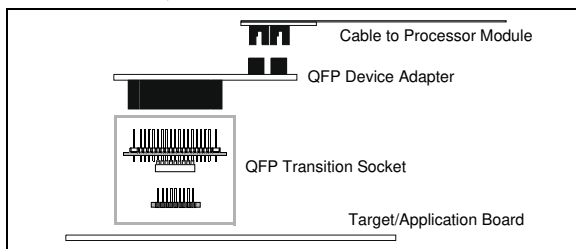


# Transition Socket Specification

## QFP TRANSITION SOCKET

QFP (MQFP, TQFP, PQFP) transition sockets and associated hardware are shown below.

**FIGURE 4: QFP TRANSITION SOCKET**



The QFP transition socket is required for use along with the QFP device adapter. The device adapter is equipped with four socket strips that interface with the transition socket.

**Note:** To avoid solder bridging, do not place vias within 0.025-inch of the QFP footprint. Also, any vias near the QFP should be directly on the centerline of the pad.

There are two parts to the QFP transition socket:

1. Adapter socket that connects to the QFP device adapter
2. QFP header that gets soldered down to the target application

Microchip offers the following QFP transition sockets:

- XLT44PT3: One 44-lead QFP adapter socket and one 44-lead QFP header (0.8 mm)
- XLT64PT5: One 64-lead QFP adapter socket and one 64-lead QFP header (0.5 mm)
- XLT80PT2: One 80-lead QFP adapter socket and one 80-lead QFP header (0.65 mm)
- XLT80PT3: One 80-lead QFP adapter socket and one 80-lead QFP header (0.5 mm)

See the drawings in this section for layout dimensions and clearances for tall components.

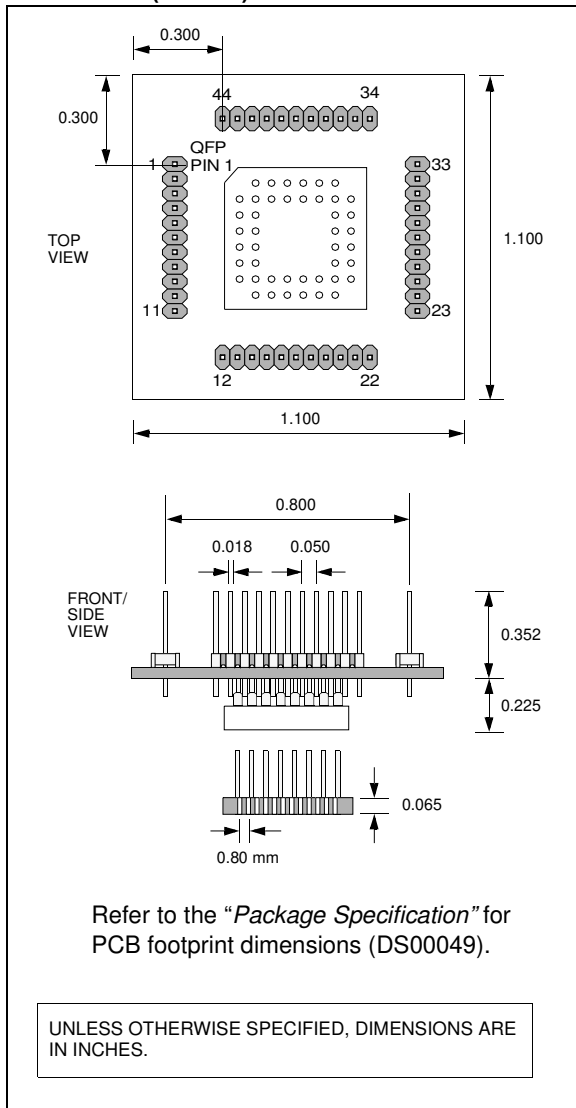
## QFP TRANSITION SOCKET SOLDERING TIPS

- Use controlled soldering iron tip temperatures between 300°C and 325°C (570°F to 615°F)
- If possible, use a PACE mini wave soldering iron tip or an equivalent tip design.
- Plan to solder one (1 of 4) side first, then the opposite side, then the remaining two sides.
- Soldering iron tip movement should be in the direction of the leads (backward and forward), not across the leads; dragging the tip across the leads may cause lead damage.
- Use generous amounts of soldering flux to aid in the solder flow action.

# Transition Socket Specification

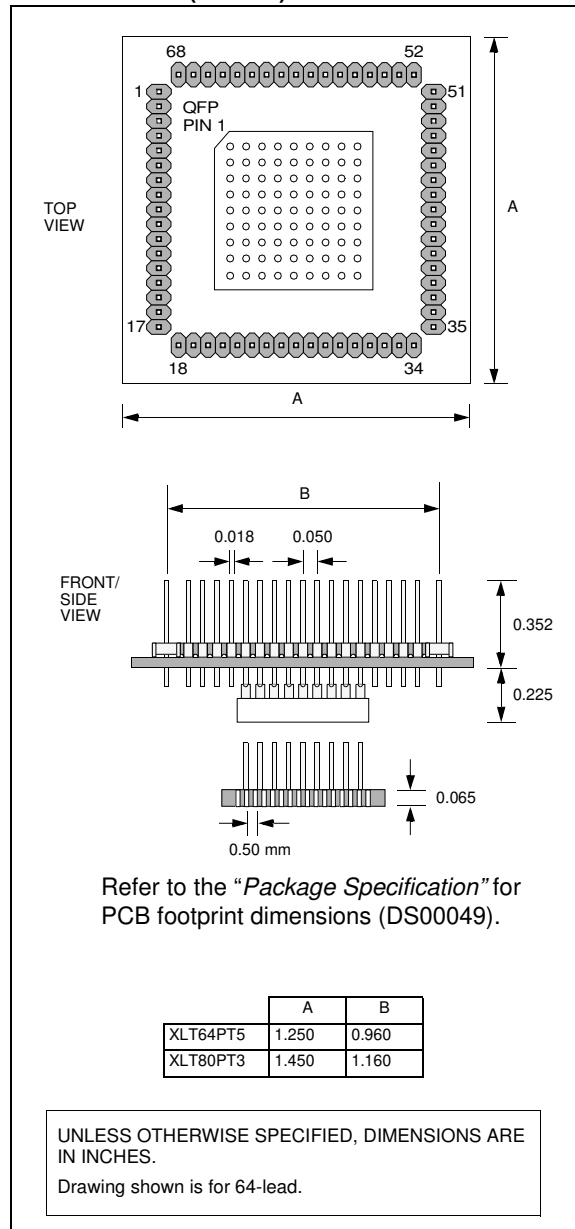
## XLT44PT3

44-lead QFP (0.8 mm)



## XLT64PT5, XLT80PT3

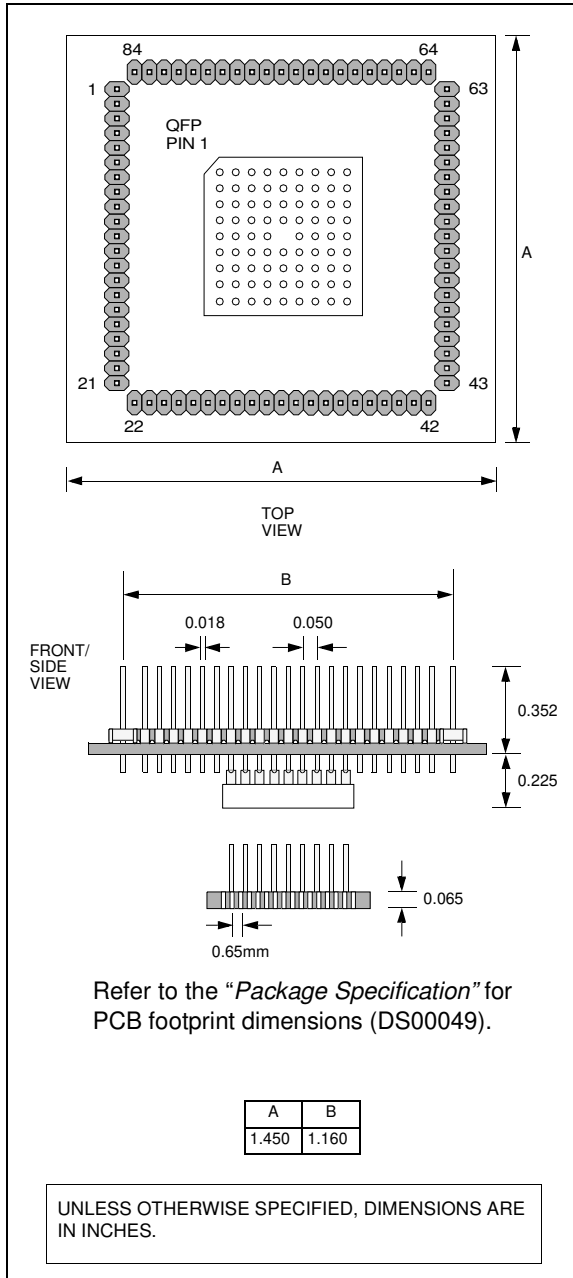
64/80-lead QFP (0.5 mm)



# Transition Socket Specification

## XLT80PT2

### 80-lead QFP (0.65 mm)



**TABLE 1: DVA/DAF INTERFACE SPECIFICATION FOR QFP PACKAGES**

| Socket   | Package Style*                      | DVA/DAF Interface Specification** |
|----------|-------------------------------------|-----------------------------------|
| XLT44PT3 | 44PT TQFP<br>44PQ MQFP<br>44KW PQFP | DVA-44PL                          |
| XLT64PT5 | 64PT                                | DVA-68PL                          |
| XLT80PT2 | 80PF                                | DVA-84PL                          |
| XLT80PT3 |                                     |                                   |

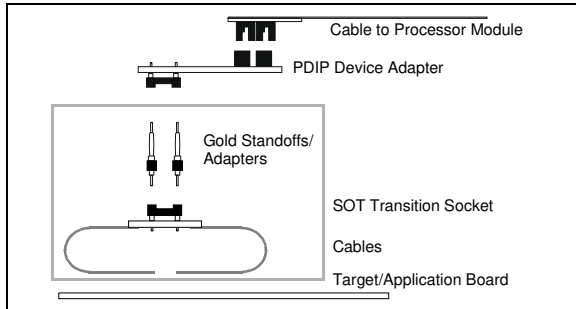
\* Refer to the "Package Specification" for PCB footprint dimensions (DS00049).  
 \*\* Refer to the processor module and device adapter specification for interface and dimensions to DVA/DAF (ICE 2000: "MPLAB<sup>®</sup> ICE 2000 Processor Module and Device Adapter Specification" (DS51140); ICE 4000: "MPLAB<sup>®</sup> ICE 4000 Processor Module and Device Adapter Specification" (DS51298)).

# Transition Socket Specification

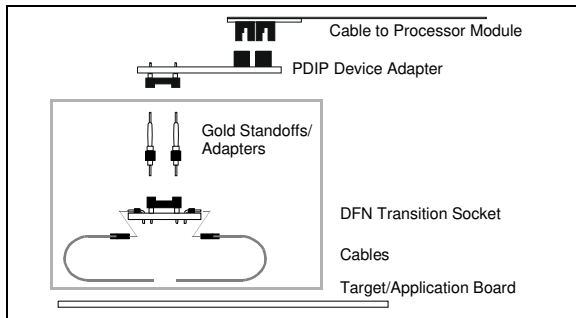
## SOT/DFN/QFN TRANSITION SOCKETS

SOT/DFN/QFN transition sockets and associated hardware are shown below.

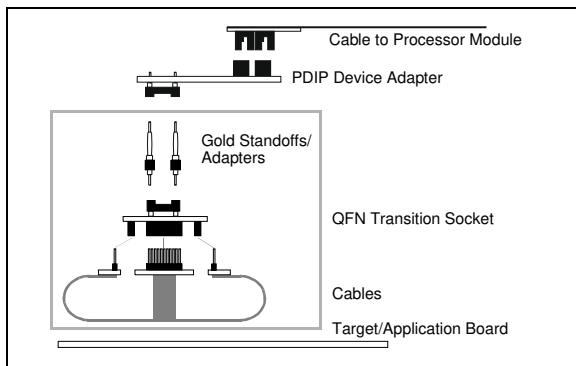
**FIGURE 5: SOT TRANSITION SOCKET WITH CABLE**



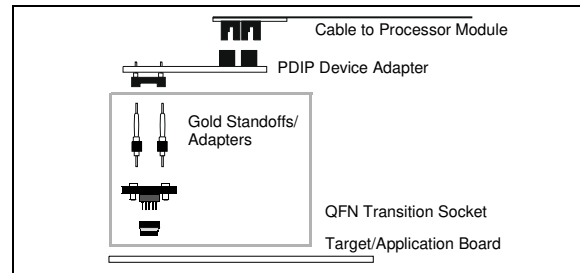
**FIGURE 6: DFN TRANSITION SOCKET WITH CABLE**



**FIGURE 7: QFN TRANSITION SOCKET WITH CABLE**



**FIGURE 8: QFN TWO-PART TRANSITION SOCKET**



Two-part transition sockets consist of:

1. Adapter socket that connects to the DIP device adapter
2. QFN header that is to be soldered down to the target application

Microchip offers the following SOT/DFN/QFN transition sockets:

- XLT06SOT: One 14-lead DIP to 6-lead SOT-23 transition socket with cable
- XLT08DFN2: One 14-lead DIP to 8-lead DFN transition socket with cable
- XLT16QFN1: One 14-lead DIP to 16-lead QFN transition socket with cable
- XLT20QFN-1: One 20-lead DIP adapter socket and one 20-lead QFN header
- XLT28QFN3: One 18-lead DIP to 28-lead QFN transition socket with cable
- XLT28QFN4: One 28-lead DIP to 28-lead QFN transition socket with cable
- XLT44QFN2: One 40-lead DIP to 44-lead QFN transition socket with cable
- XLT44QFN3: One 28-lead DIP to 44-lead QFN transition socket with cable
- XLT44QFN4: One 28-lead DIP to 44-lead QFN transition socket with cable
- XLT44QFN5: One 18-lead DIP to 44-lead QFN transition socket with cable

See the drawings in this section for layout dimensions.

# Transition Socket Specification

## RECOMMENDED INSTALLATION OF TRANSITION SOCKETS WITH CABLES

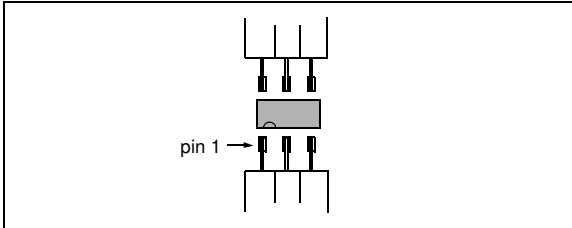
For transition sockets that use a cable, follow these instructions for installing your transition socket on the target board.

### PCB Layout Considerations:

Make sure you leave enough room on the PCB to accommodate the cable, i.e., space your target pads for each device far enough apart so that the cable from one pad group will not interfere with another pad group.

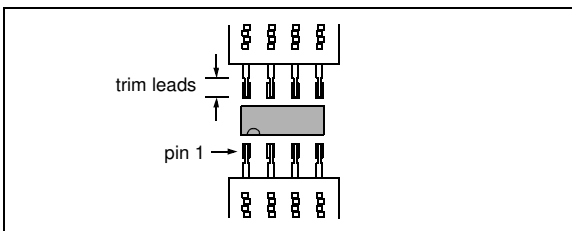
### 6-Pin SOT Solder Instructions:

1. Remove protective cable covering from end of cable.
2. Position cables on target board (see below). Tape down to prevent movement.
3. Solder each lead to target pad.
4. Remove tape and clean.



### 8-Pin DFN Solder Instructions:

1. Prepare leads by trimming narrowest portion to 0.10-inch maximum in length (see below).
2. Position cables on target board (see below). Tape down to prevent movement.
3. Solder each lead to target pad.
4. Remove tape and clean.



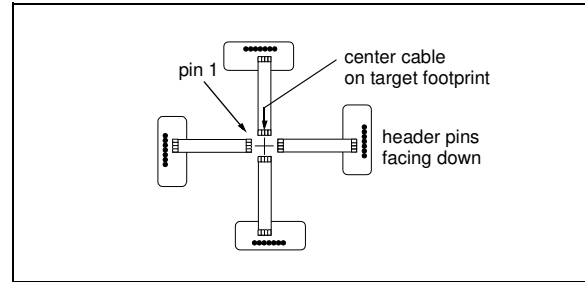
### 8-Pin DFN Assembly Instructions:

1. Start with cable associated with pin 1.
2. Fold cable up and over, forming a radius.
3. Mate with the header on the side of the transition socket assembly, making sure pin 1 mates with the pin labeled "DFN Pin 1".
4. Fold over and mate the other cable.

### 16-Pin QFN Solder Instructions:

1. Remove protective cable jacket from stripped end of cable.
2. Lay out the four cables in a "+" pattern (see below).

3. Center each cable on the footprint (see below). Tape down each cable to prevent movement.
4. Solder each lead to target pad.
5. Remove tape and clean

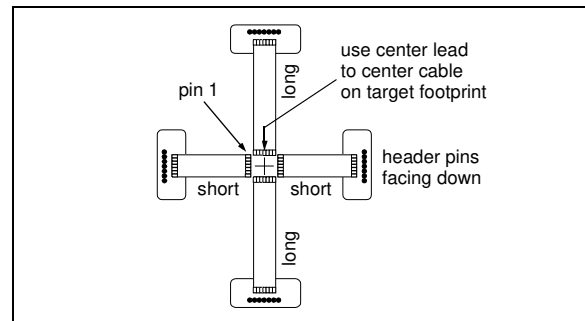


### 16-Pin QFN Assembly Instructions:

1. Start with cable associated with pin 1.
2. Fold cable up and over, forming a radius. Header pins will now be facing upwards.
3. Mate with the socket on the underside of the transition socket assembly, making sure pin 1 mates with the pin labeled "QFN Pin 1".
4. Fold over and mate the other cables.

### 28/44-Pin QFN Solder Instructions:

1. Remove protective cable jacket from stripped end of cable.
2. Lay out with long cables opposing each other and short cables opposing each other (see below).
3. Place center lead (6th lead for 44-pin, 4th lead for 28-pin) on center target pad to center each cable on the footprint (see below). Tape down each cable to prevent movement.
4. Solder each lead to target pad.
5. Remove tape and clean



### 28/44-Pin QFN Assembly Instructions:

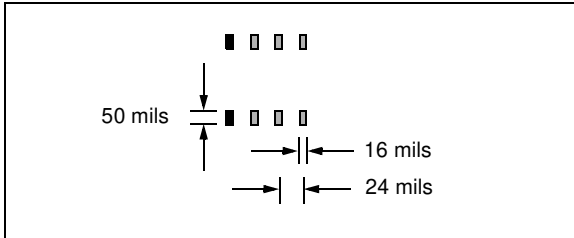
1. Start with cable associated with pin 1.
2. Fold cable up and over, forming a radius. Header pins will now be facing upwards.
3. Mate with the socket on the underside of the transition socket assembly, making sure pin 1 mates with the pin labeled "QFN Pin 1".
4. Fold over and mate the other cables.

# Transition Socket Specification

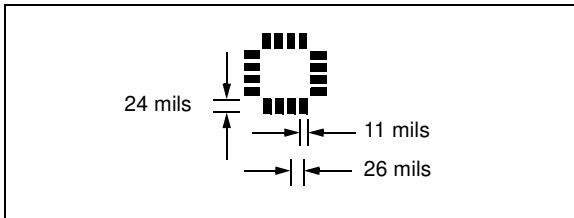
## RECOMMENDED PCB LAYOUT

The recommended target board footprint layout for different pin-counts is shown here.

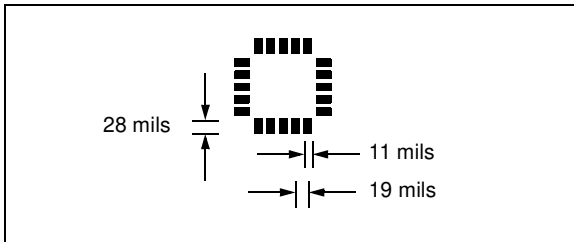
**FIGURE 9: 6-PIN SOT, 8-PIN DFN**



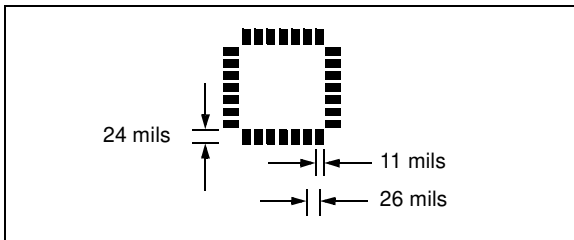
**FIGURE 10: 16-PIN QFN**



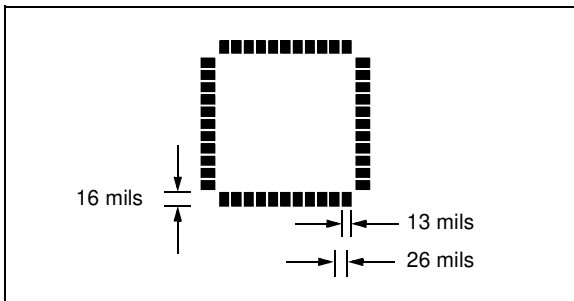
**FIGURE 11: 20-PIN QFN**



**FIGURE 12: 28-PIN QFN**

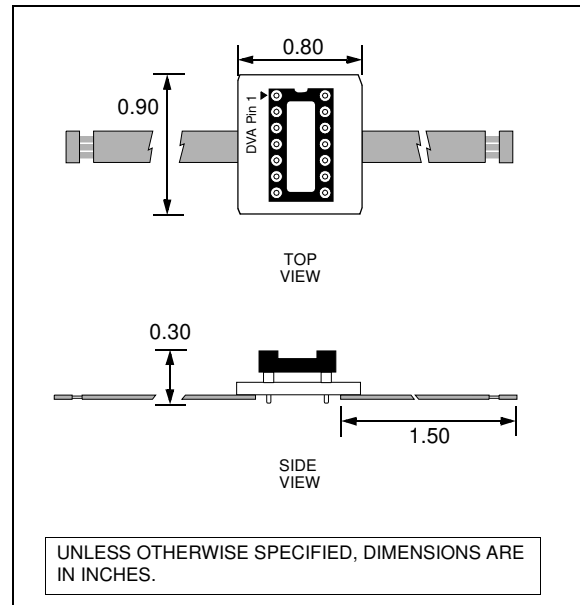


**FIGURE 13: 44-PIN QFN**



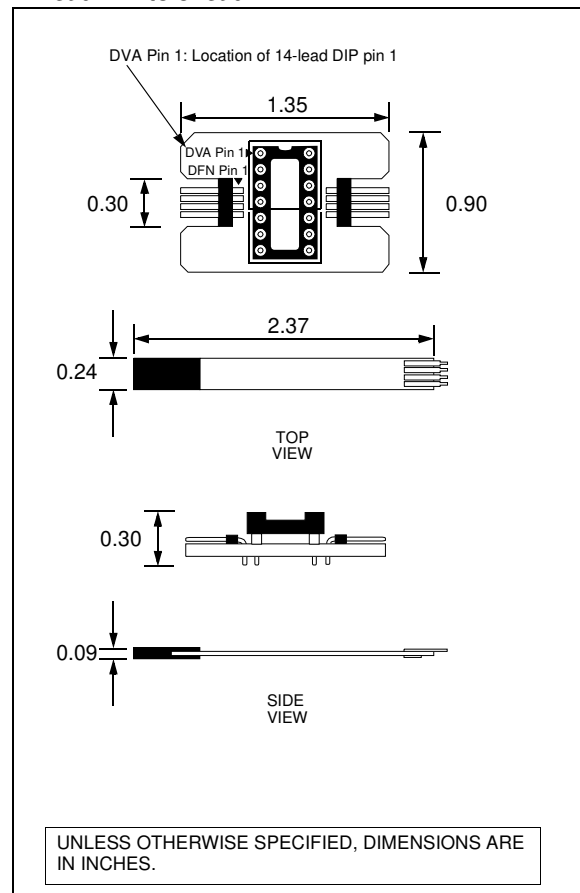
## XLT06SOT

### 14-lead DIP to 6-lead SOT-23



## XLT08DFN2

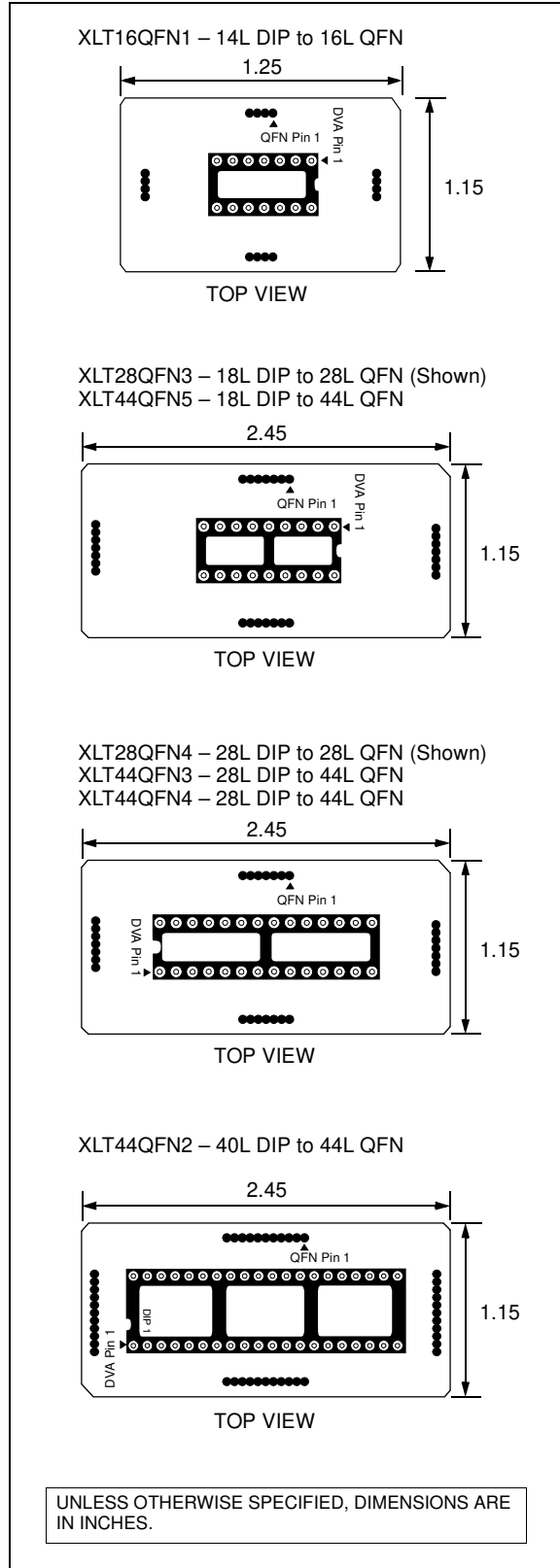
### 14-lead DIP to 8-lead DFN



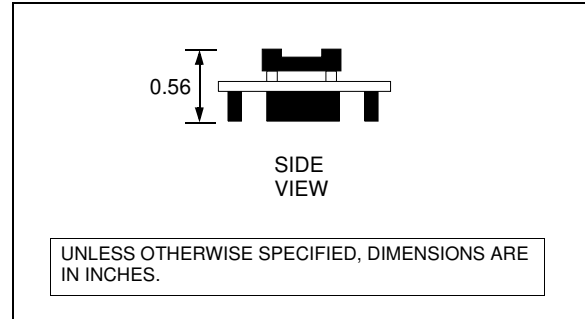
# Transition Socket Specification

**XLT16QFN1, XLT28QFN3, XLT28QFN4,  
XLT44QFN2, XLT44QFN3, XLT44QFN4,  
XLT44QFN5**

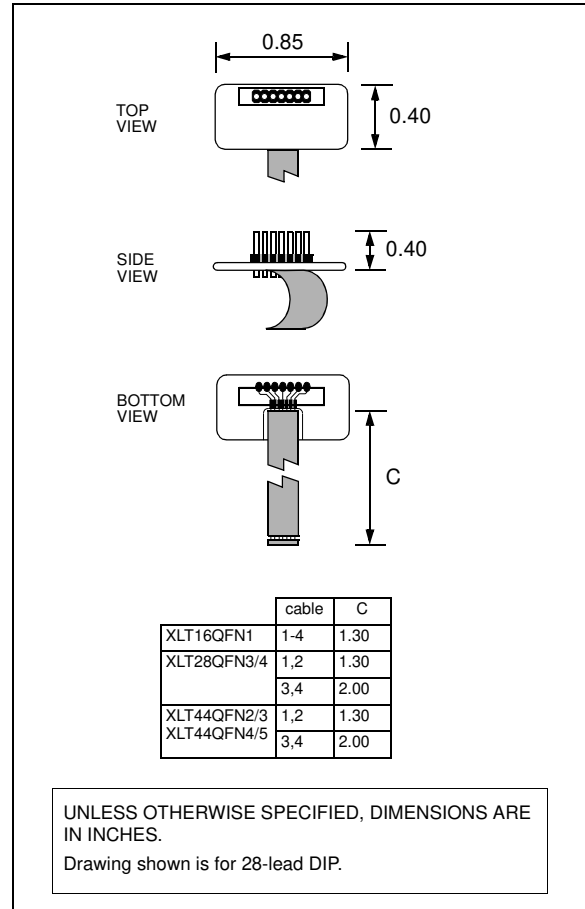
## Multi-lead DIP to Multi-lead QFN, Top View



## Multi-lead DIP to Multi-lead QFN, Side View



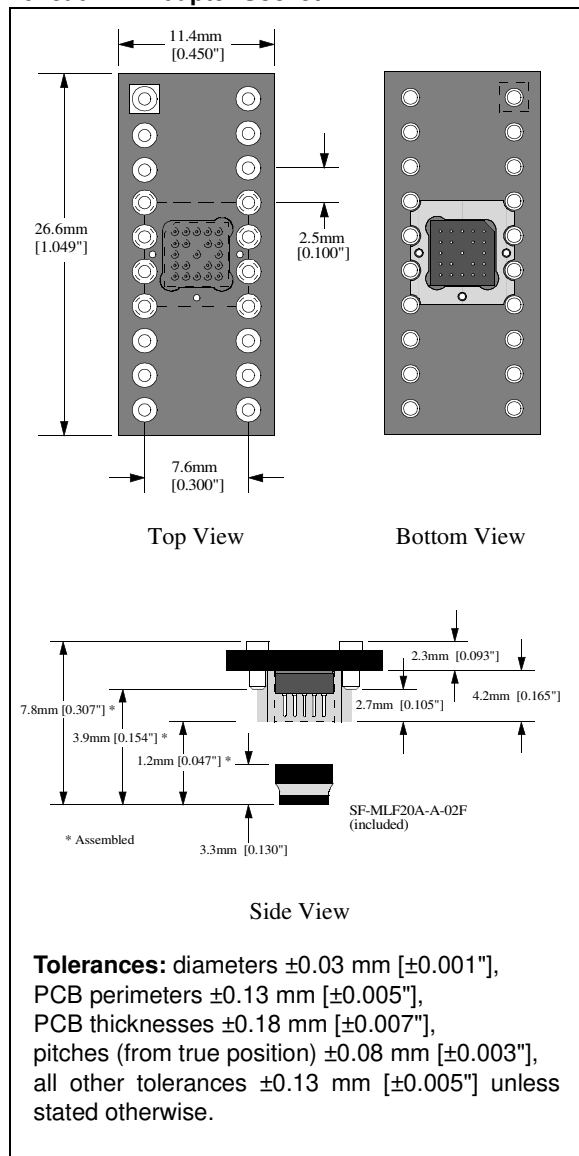
## Multi-lead DIP to Multi-lead QFN Cables



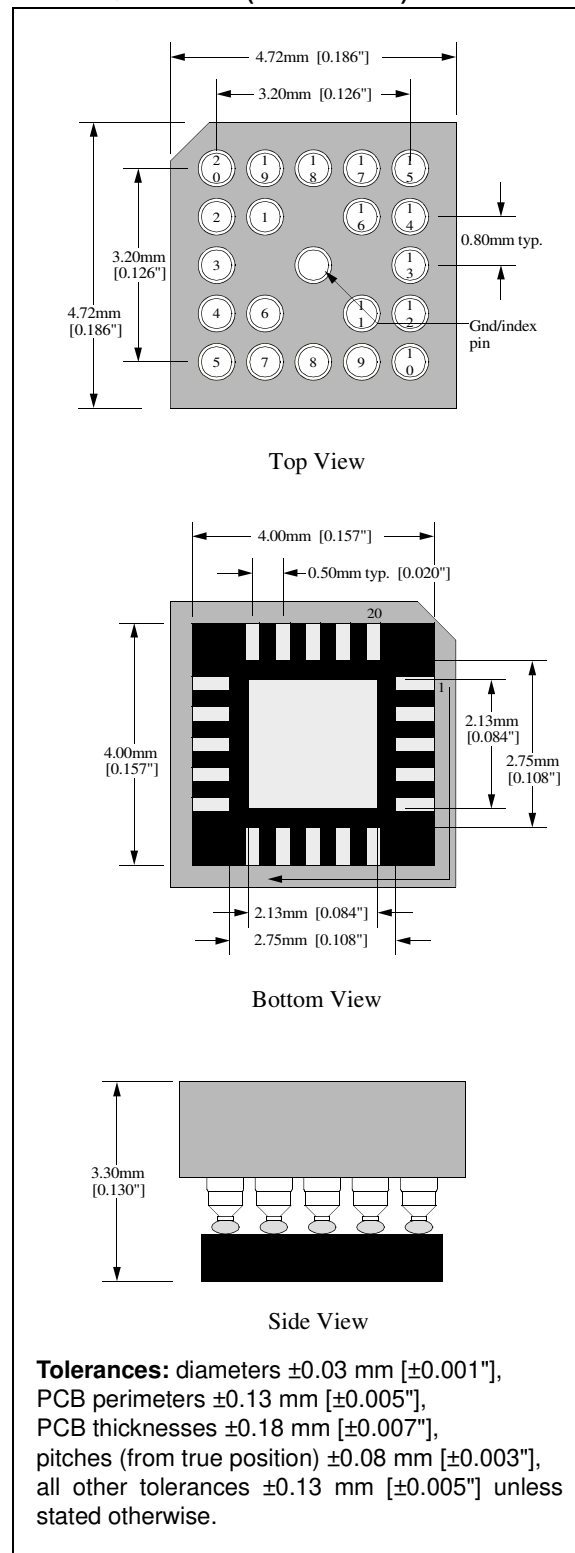
# Transition Socket Specification

## XLT20QFN-1

### 20-lead DIP Adapter Socket



### 20-lead QFN Header (Surface Foot)





# Transition Socket Specification

---

## **XLT20QFN-1 Soldering Suggestions**

This socket is difficult to solder since the device pins are not exposed, but embedded, into the socket's Surface Foot (SF).

1. To start, add tack flux to the target land pattern.
2. Visually align the QFN SF with the target land pattern. Then solder two opposite SF pins to the target lands so that the SF does not move around.
3. Finish soldering the rest of the SF pins.
4. If the SF has a middle ground pin, feed solder through the bottom side of the target board via holes. This will connect the center QFN SF pin to the target board.
5. Check each solder connection on the QFN SF pins.

You are now ready to attach the QFN header to the SF.

# Transition Socket Specification

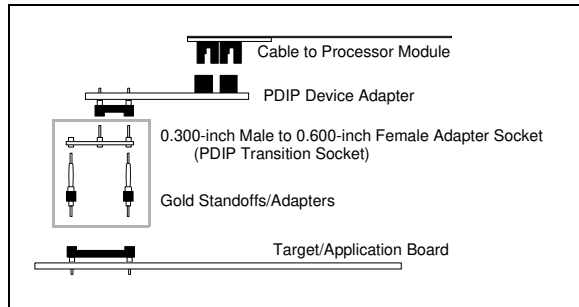
## DISCONTINUED SOCKETS

The transition sockets in this section are discontinued and may no longer be ordered from Microchip. They are kept in this document as a reference for customers who still have these sockets.

### PDIP TRANSITION SOCKET

A PDIP transition socket and associated hardware is shown in Figure 1.

**FIGURE 1: PDIP TRANSITION SOCKET**



The PDIP transition socket is a 0.300-inch Male to 0.600-inch Female adapter socket.

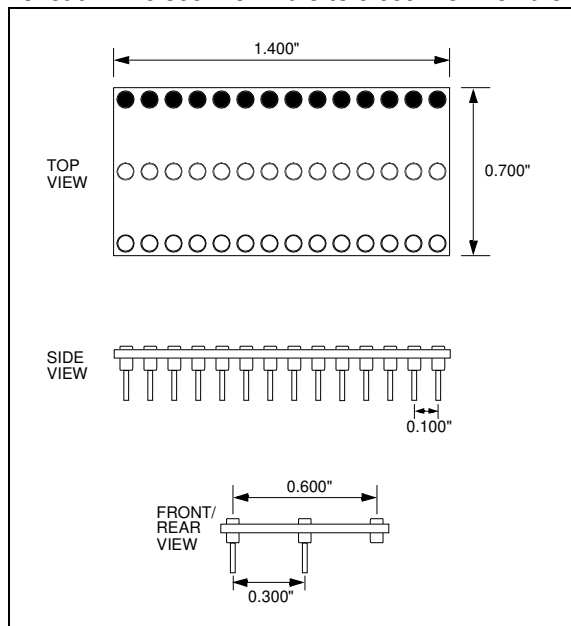
Microchip offers the following PDIP transition socket:

- XLT28XP: One 28-lead DIP transition socket and two 28-lead gold standoffs

See the drawings in this section for layout dimensions.

### XLT28XP (Discontinued)

#### 28-lead DIP 0.300-inch Male to 0.600-inch Female

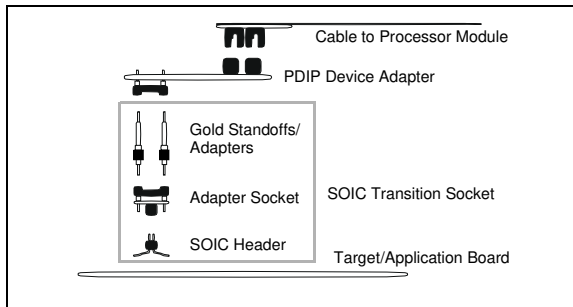


# Transition Socket Specification

## SOIC TRANSITION SOCKET

An SOIC transition socket and associated hardware is shown in Figure 2.

**FIGURE 2: SOIC TRANSITION SOCKET**



There are two components of the SOIC transition socket:

1. Adapter socket that connects to the PDIP device adapter
2. SOIC header that is to be soldered down to the target application

The following SOIC transition sockets have been discontinued:

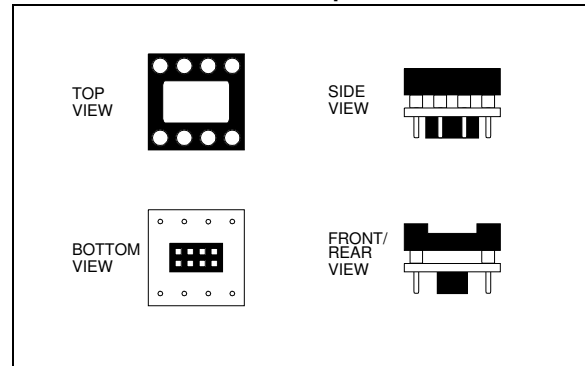
- XLT08SO: One adapter socket and three 8-lead SOIC headers
- XLT14SO: One adapter socket and three 14-lead SOIC headers
- XLT18SO: One adapter socket and three 18-lead SOIC headers
- XLT20SO1: One adapter socket and three 20-lead SOIC headers
- XLT28SO: One adapter socket and three 28-lead SOIC headers

See the drawings in this section for layout dimensions.

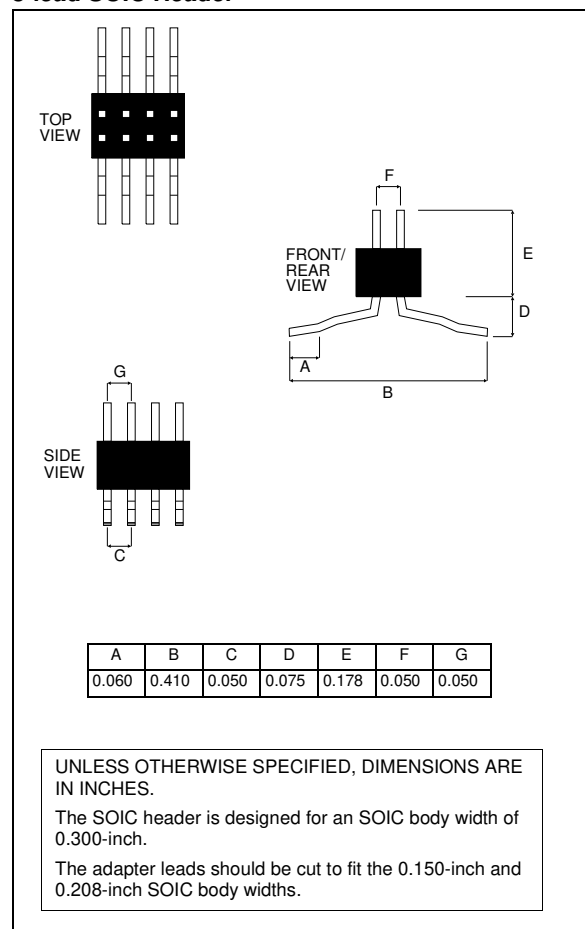
**Note:** The SOIC header is designed for SOIC body width of 0.300-inch. The adapter leads should be cut to fit the 0.150-inch and 0.208-inch SOIC body widths.

## XLT08SO (Discontinued – see XLT08SO-1 or XLT08SN-1)

### 8-lead DIP to 0.050-inch Adapter Socket



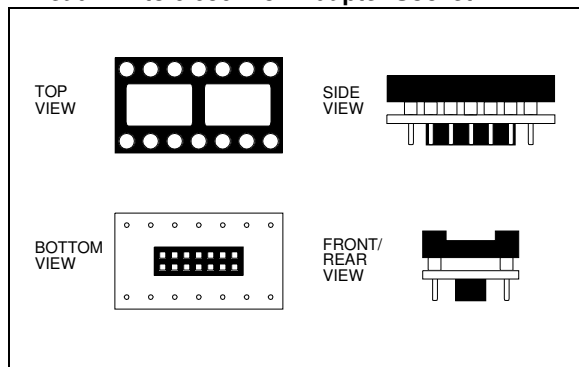
### 8-lead SOIC Header



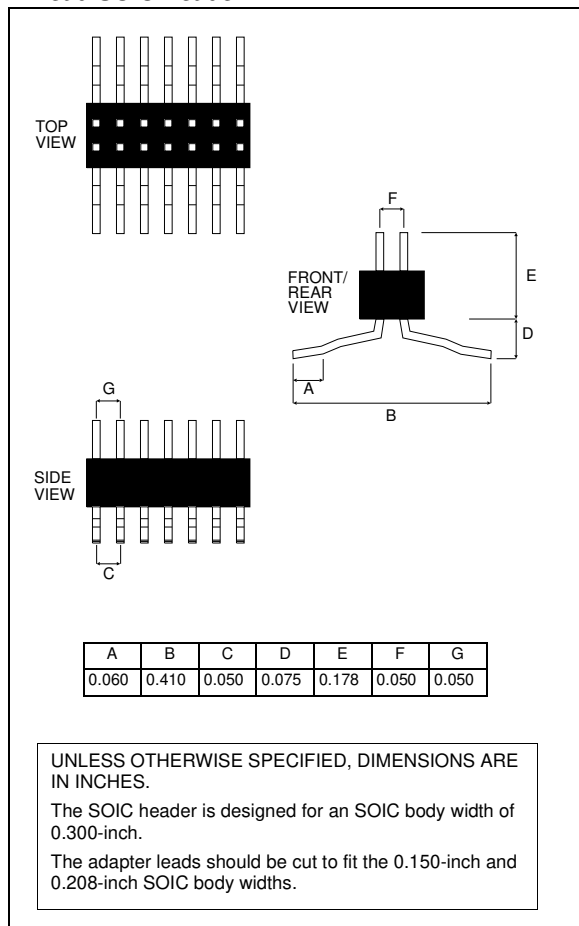
# Transition Socket Specification

## XLT14SO (Discontinued – see XLT14SO-1)

### 14-lead DIP to 0.050-inch Adapter Socket

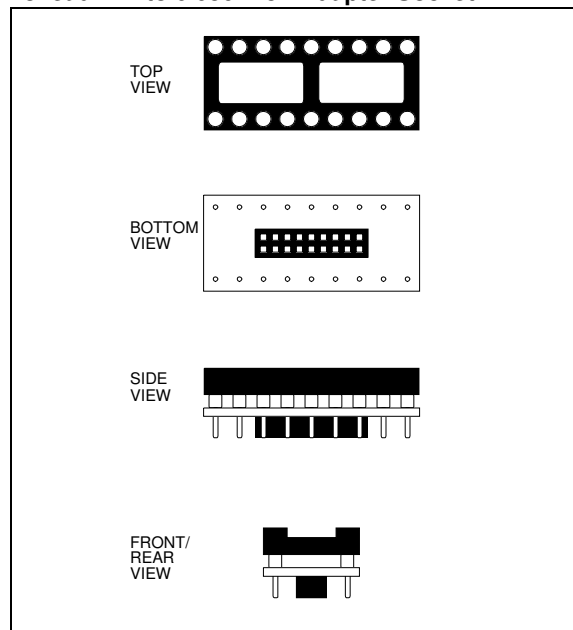


### 14-lead SOIC Header

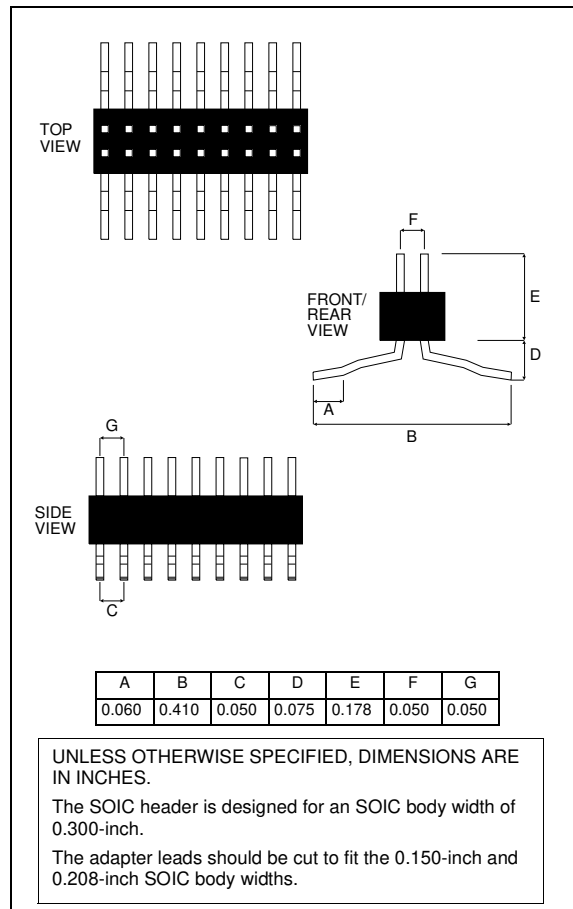


## XLT18SO (Discontinued – see XLT18SO-1)

### 18-lead DIP to 0.050-inch Adapter Socket



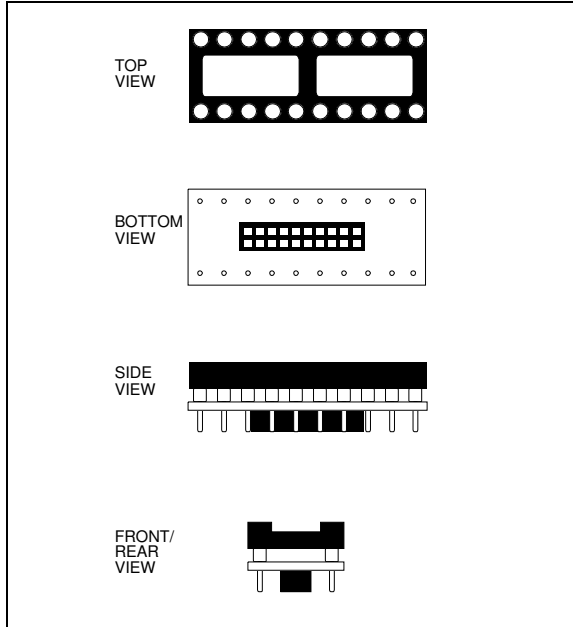
### 18-lead SOIC Header



# Transition Socket Specification

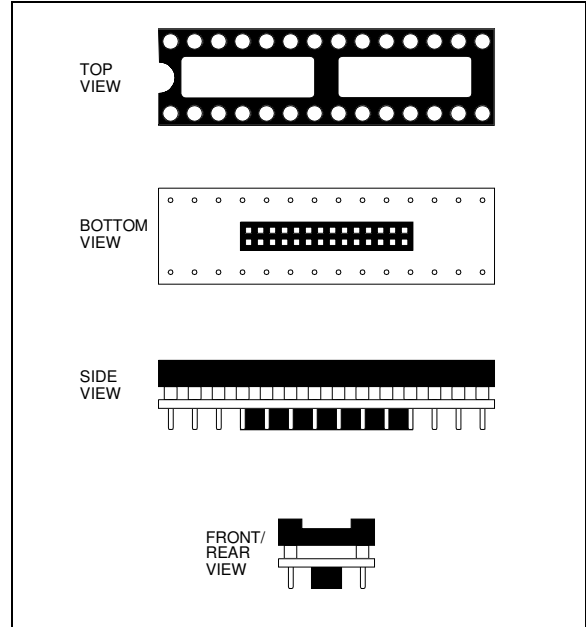
## XLT20SO1 (Discontinued – see XLT20SO1-1)

### 20-lead DIP to 0.050-inch Adapter Socket

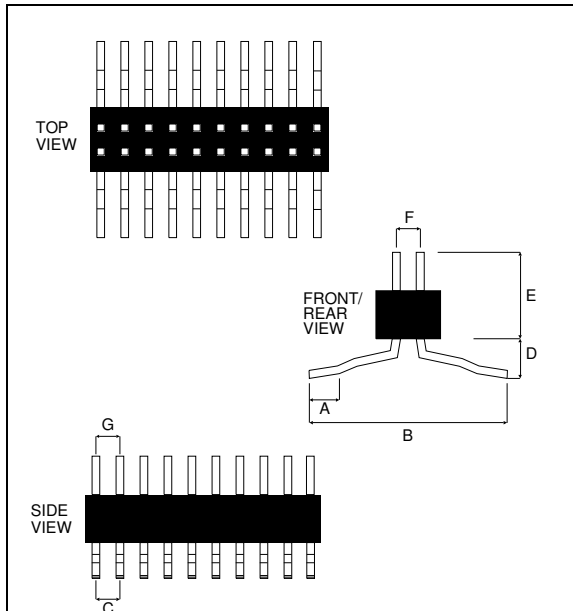


## XLT28SO (Discontinued – see XLT28SO-1)

### 28-lead DIP to 0.050-inch Adapter Socket



## 20-lead SOIC Header



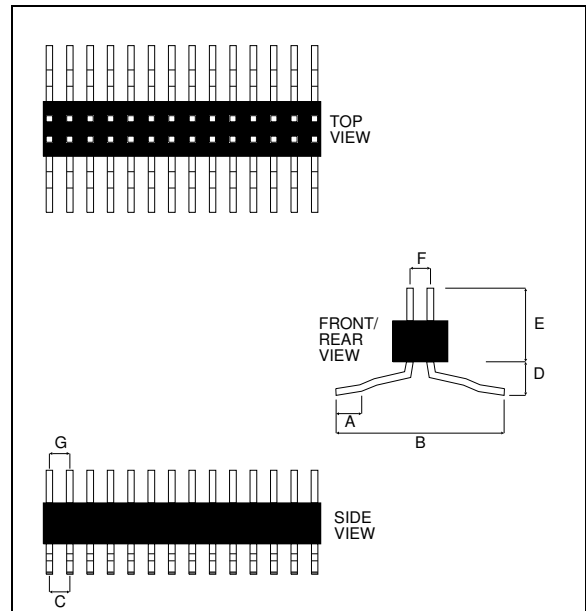
| A     | B     | C     | D     | E     | F     | G     |
|-------|-------|-------|-------|-------|-------|-------|
| 0.060 | 0.410 | 0.050 | 0.075 | 0.178 | 0.050 | 0.050 |

UNLESS OTHERWISE SPECIFIED, DIMENSIONS ARE IN INCHES.

The SOIC header is designed for an SOIC body width of 0.300-inch.

The adapter leads should be cut to fit the 0.150-inch and 0.208-inch SOIC body widths.

## 28-lead SOIC Header



| A     | B     | C     | D     | E     | F     | G     |
|-------|-------|-------|-------|-------|-------|-------|
| 0.060 | 0.410 | 0.050 | 0.075 | 0.178 | 0.050 | 0.050 |

UNLESS OTHERWISE SPECIFIED, DIMENSIONS ARE IN INCHES.

The SOIC header is designed for an SOIC body width of 0.300-inch.

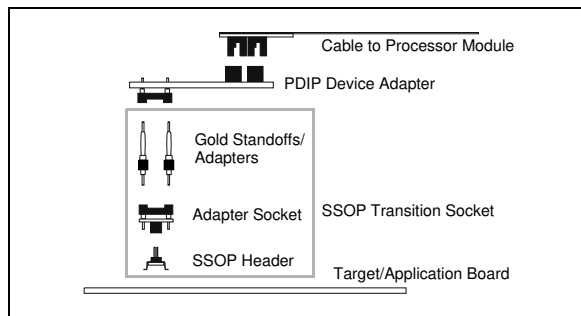
The adapter leads should be cut to fit the 0.150-inch and 0.208-inch SOIC body widths.

# Transition Socket Specification

## SSOP TRANSITION SOCKET

An SSOP transition socket and associated hardware is shown in Figure 3.

**FIGURE 3: SSOP TRANSITION SOCKET**



The SSOP transition sockets are similar to the SOIC transition sockets. There are two parts to the SSOP transition socket:

1. Adapter socket that connects to the PDIP device adapter.
2. SSOP header that gets soldered down to the target application.

**Note:** To keep the leads straight during assembly and shipping, the SSOP headers are shipped with break-away tabs attached to the leads. Please remove the break-away tabs before applying power to the target system. Be careful not to bend the leads prior to soldering to the target application.

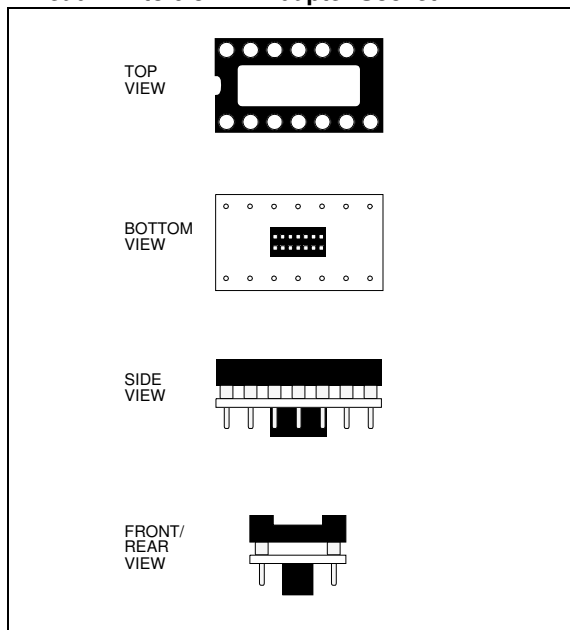
The following SSOP transition sockets have been discontinued:

- XLT14SS: One adapter socket and three 14-lead SSOP headers
- XLT20SS: One adapter socket and three 20-lead SSOP headers
- XLT20SS1: One adapter socket and three 20-lead SSOP headers
- XLT28SS: One adapter socket and three 28-lead SSOP headers
- XLT28SS2: One adapter socket and three 28-lead SSOP headers for PIC16C55/57

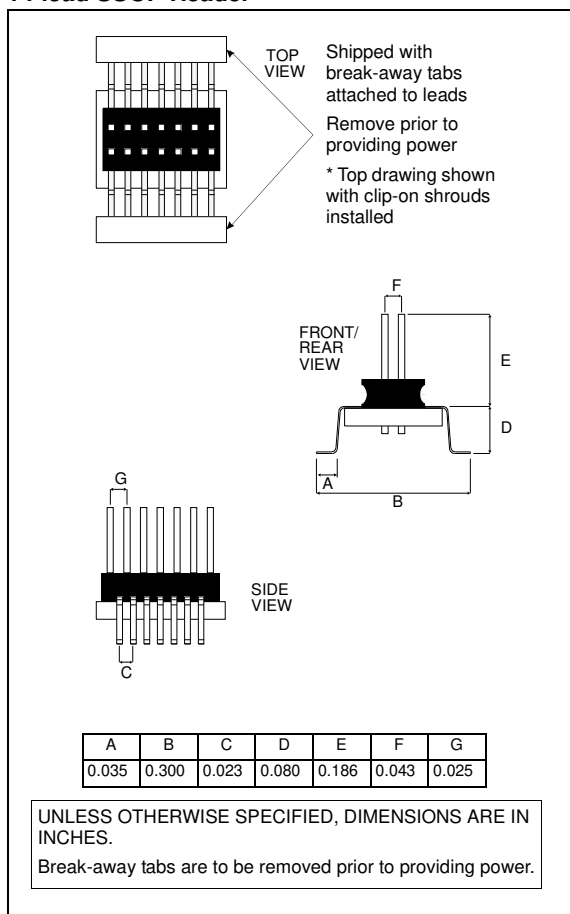
See the drawings in this section for layout dimensions and clearances for tall components.

## XLT14SS (Discontinued – see XLT14SS-1)

### 14-lead DIP to 0.8 mm Adapter Socket



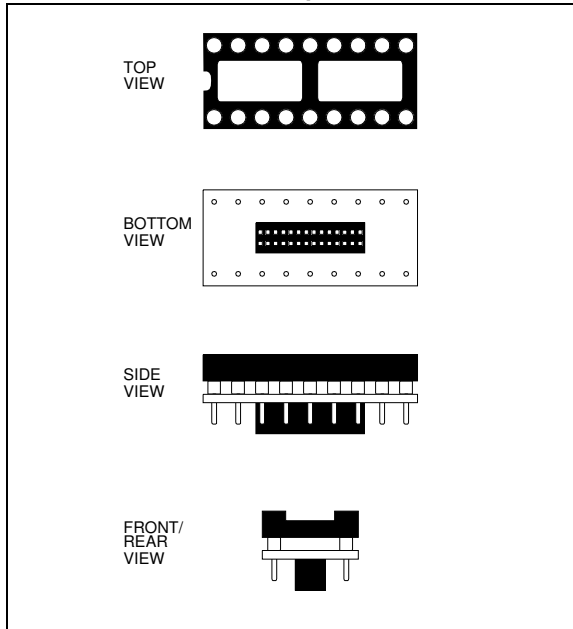
### 14-lead SSOP Header



# Transition Socket Specification

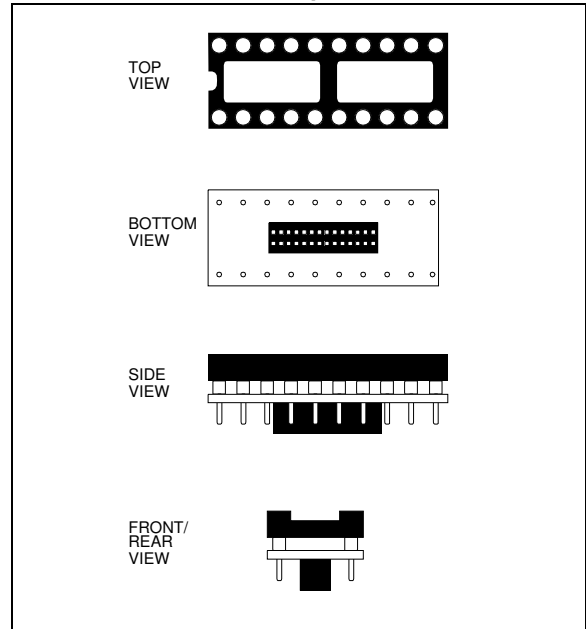
## XLT20SS (Discontinued – see XLT20SS-1)

### 18-lead DIP to 0.8 mm Adapter Socket

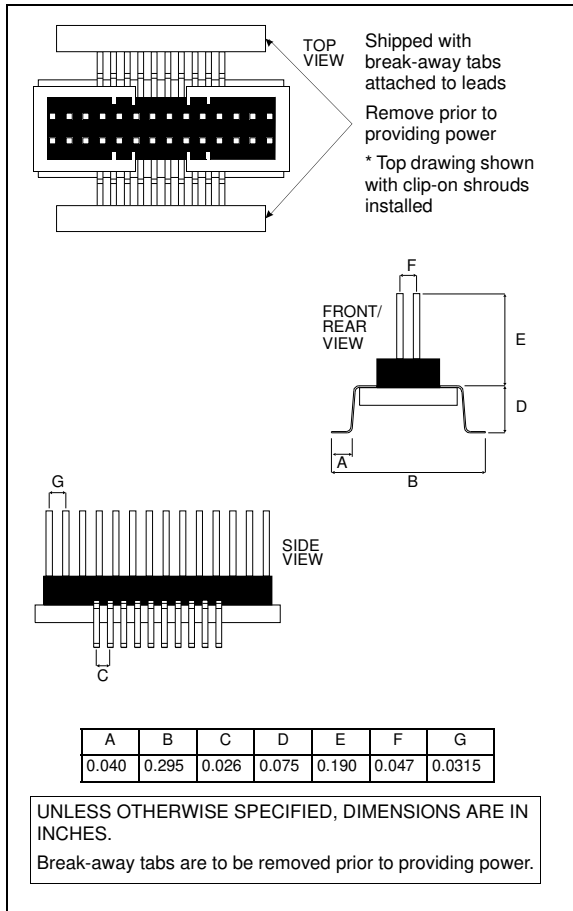


## XLT20SS1 (Discontinued – see XLT20SS1-1)

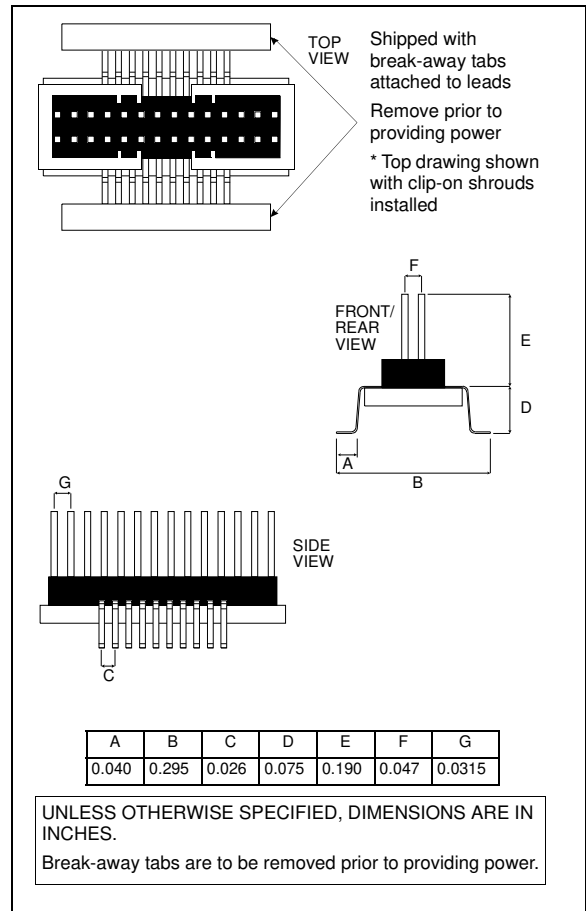
### 20-lead DIP to 0.8 mm Adapter Socket



## 20-lead SSOP Header



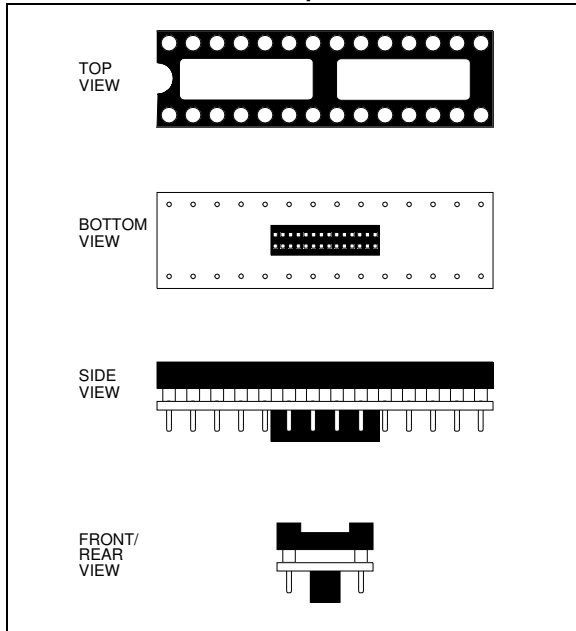
## 20-lead SSOP Header



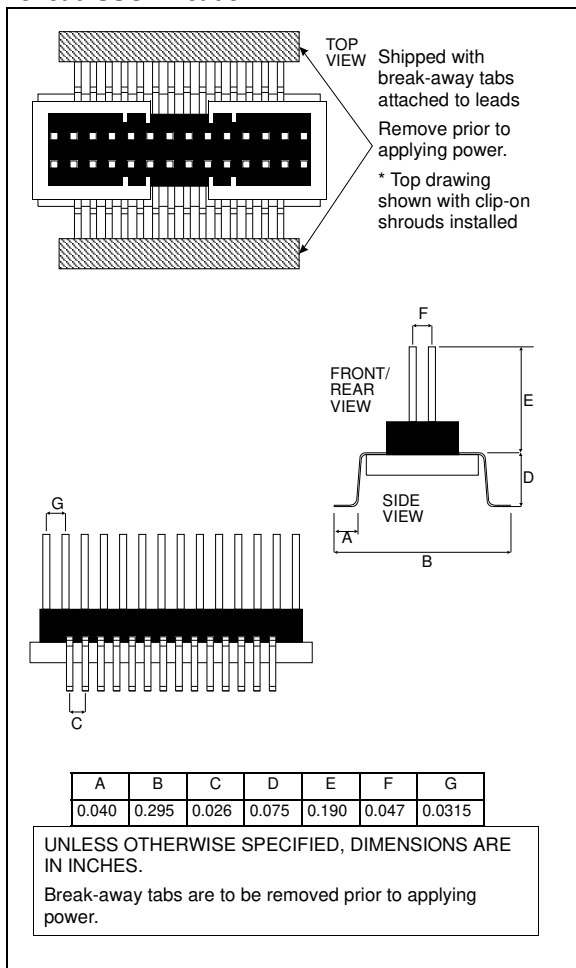
# Transition Socket Specification

XLT28SS (Discontinued – see XLT28SS-1)  
 XLT28SS2 (Discontinued – see XLT28SS2-1)

## 28-lead DIP to 0.8 mm Adapter Socket



## 28-lead SSOP Header



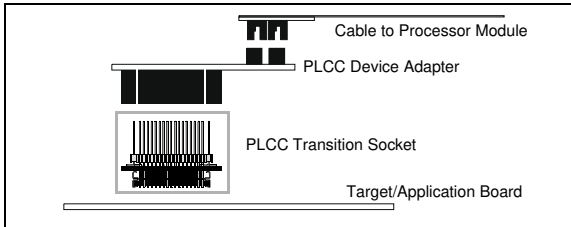


# Transition Socket Specification

## PLCC TRANSITION SOCKET

A PLCC transition socket and associated hardware is shown in Figure 4.

**FIGURE 4: PLCC TRANSITION SOCKET**



The PLCC transition socket is required for use along with the PLCC device adapters. The DAF18-1 device adapter is equipped with eight socket strips that interface with one of two transition sockets. The DAF18-3 device adapter is equipped with four socket strips that interface with one transition socket.

The PLCC transition sockets are designed with a threaded insert in the center of the footprint so that a 4/40 screw can securely fasten the transition socket to the device adapter.

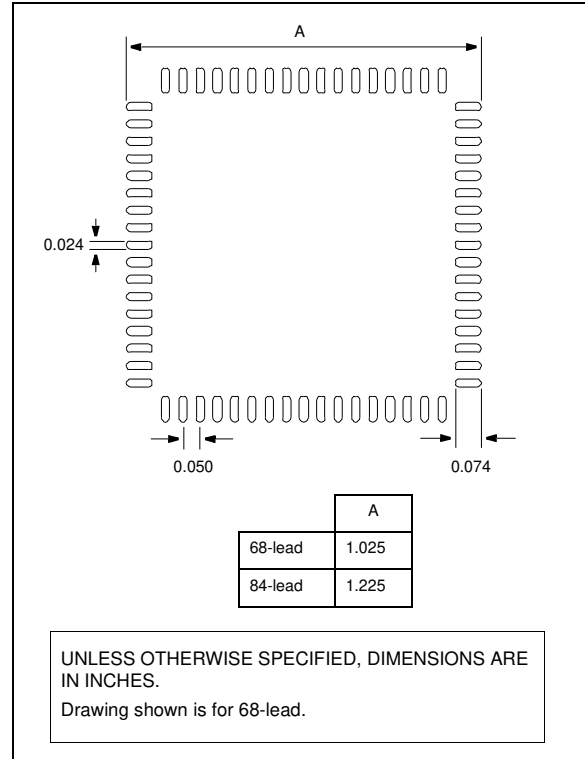
The PLCC transition sockets are designed to be soldered to the target PCB PLCC surface mount pattern or inserted into a PLCC socket on the target PCB.

**Note:** To avoid solder bridging, do not place vias within 0.025-inch of the PLCC footprint. Also, any vias near the PLCC should be directly on the centerline of the pad.

The following PLCC transition sockets have been discontinued:

- XLT68L1: One 68-lead PLCC transition socket
- XLT84L1: One 84-lead PLCC transition socket

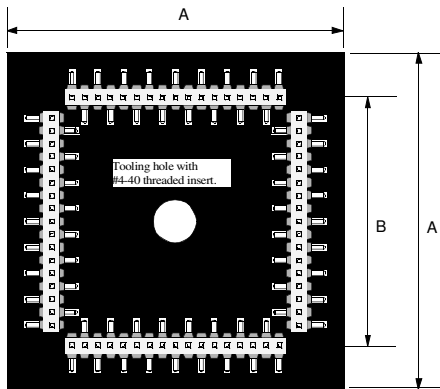
## RECOMMENDED PCB LAYOUT



# Transition Socket Specification

XLT68L1, XLT84L1 (Discontinued)

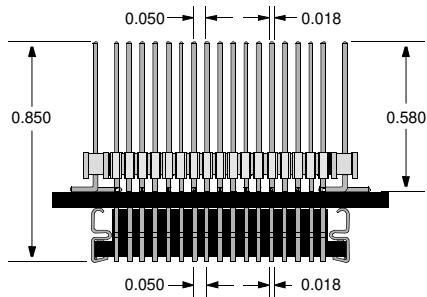
## 68/84-lead Adapter Socket



TOP VIEW

|         | A     | B     |
|---------|-------|-------|
| 68-lead | 1.300 | 0.960 |
| 84-lead | 1.400 | 1.160 |

**\*Caution:** Pin 1 on the device adapter side (top of socket) is 180 degrees from pin 1 on the target side (bottom of socket).



FRONT/  
SIDE  
VIEW

UNLESS OTHERWISE SPECIFIED, DIMENSIONS ARE IN INCHES.

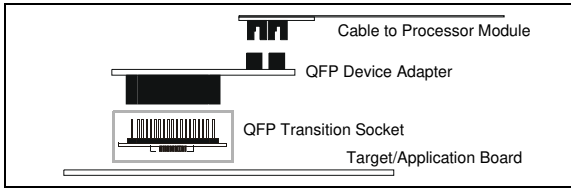
Drawing shown is for 68-lead.

# Transition Socket Specification

## QFP TRANSITION SOCKET

QFP (MQFP, TQFP, PQFP) transition sockets and associated hardware are shown below.

**FIGURE 5: QFP TRANSITION SOCKET**



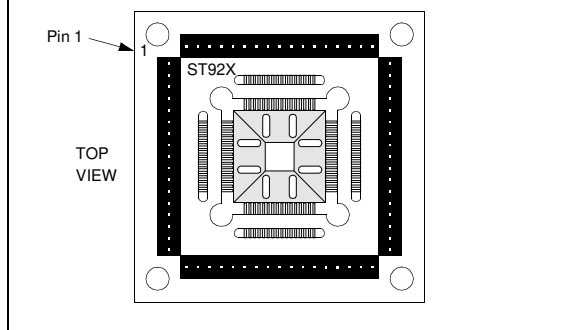
The QFP transition socket is required for use along with the QFP device adapter. The device adapter is equipped with four socket strips that interface with the transition socket.

**Note:** To avoid solder bridging, do not place vias within 0.025-inch of the QFP footprint. Also, any vias near the QFP should be directly on the centerline of the pad.

The following QFP transition sockets have been discontinued:

- XLT44PT: One 44-lead QFP transition socket, 0.80 mm
- XLT64PT1: One 64-lead QFP transition socket, 0.5 mm (PIC16C92X)

**Note:** The XLT64PT1 for the PIC16C92X is not symmetrical. Please note Pin 1 orientation prior to soldering to the target system.



- XLT64PT2: One 64-lead QFP transition socket, 0.5 mm (PIC17CXXX)
- XLT64PT3: One 64-lead QFP transition socket, 0.8 mm (dsPIC30F)
- XLT64PT4: One 64-lead QFP adapter socket and one 64-lead QFP header (0.8 mm)
- XLT80PT: One 80-lead QFP transition socket, 0.5 mm

## QFP TRANSITION SOCKET SOLDERING TIPS

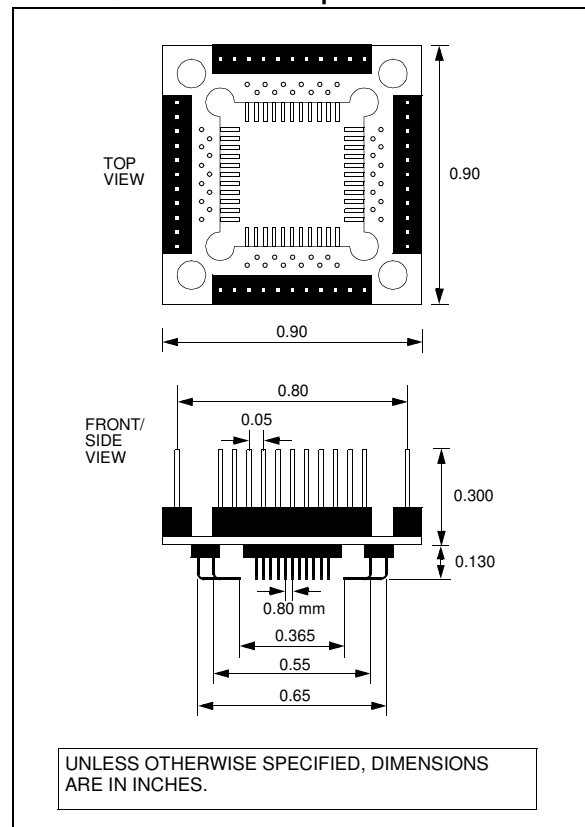
- Before soldering, consider keeping the break-away tabs in place during soldering.
- Use controlled soldering iron tip temperatures between 300°C and 325°C (570°F to 615°F)
- If possible, use a PACE mini wave soldering iron tip or an equivalent tip design.
- Plan to solder one (1 of 4) side first, then the opposite side, then the remaining two sides.
- Soldering iron tip movement should be in the direction of the leads (backward and forward), not across the leads; dragging the tip across the leads may cause lead damage.
- Use generous amounts of soldering flux to aid in the solder flow action.
- If the break-away tabs are removed after soldering (using a dental pick or equivalent), any solder bridging between leads can be repaired by simply gently touching the soldering tip to the lead tip.

### CAUTION

**The 64 and 80-pin QFP headers are very delicate and can be easily damaged!**

## XLT44PT (Discontinued – see XLT44PT3)

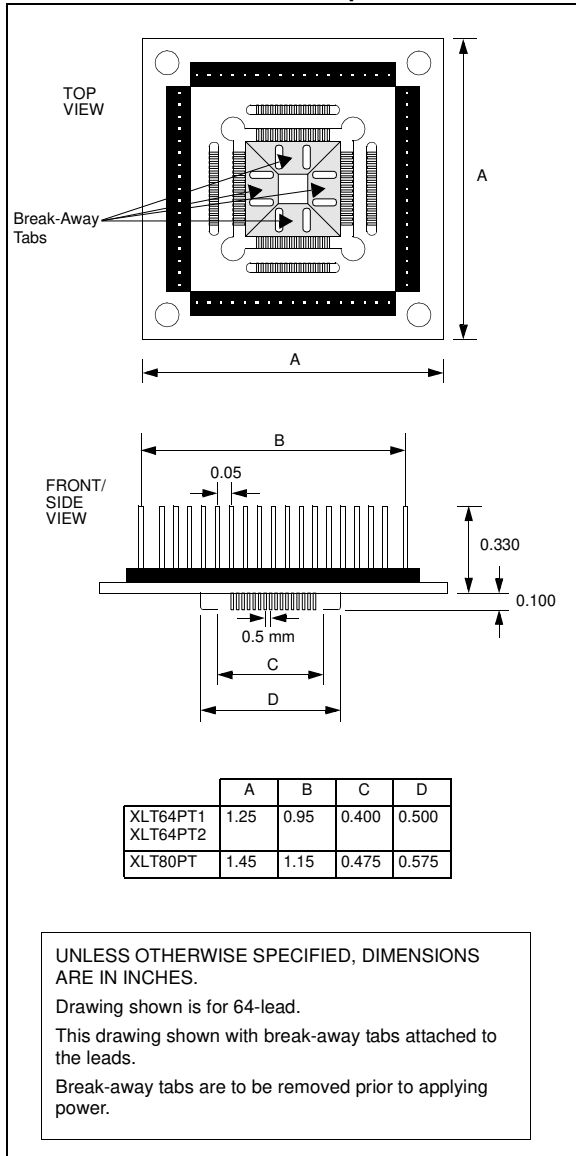
### 44-lead QFP to 0.8 mm Adapter Socket



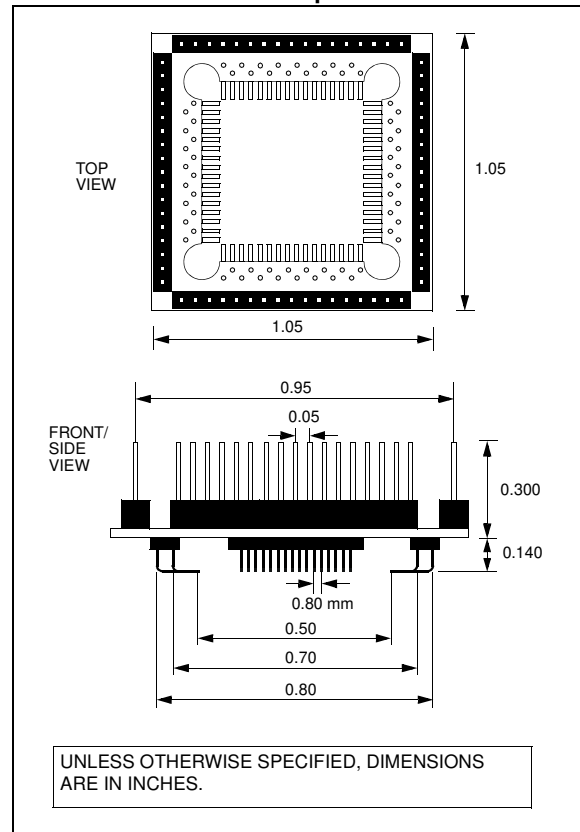
# Transition Socket Specification

XLT64PT1 (Discontinued)  
 XLT64PT2 (Discontinued – see XLT64PT5)  
 XLT80PT (Discontinued – see XLT80PT3)

64/80-lead QFP to 0.5 mm Adapter Socket



XLT64PT3 (Discontinued – see XLT64PT5)  
 64-lead QFP to 0.8mm Adapter Socket



# Transition Socket Specification

## XLT64PT4 (Discontinued – see XLT64PT5)

64-lead QFP (0.8 mm)

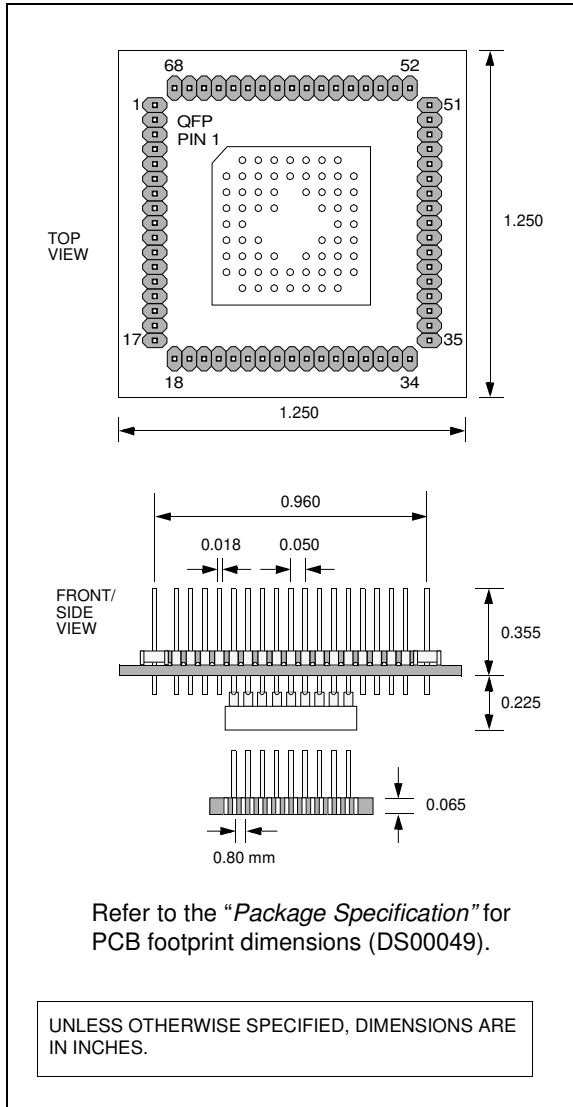


TABLE 1: DVA/DAF INTERFACE SPECIFICATION FOR QFP PACKAGES

| Socket   | Package Style*                                     | DVA/DAF Interface Specification** |
|----------|--|-----------------------------------|
| XLT44PT  | 44PT TQFP<br>44PQ MQFP<br>44KW PQFP                | DVA-44PL                          |
| XLT64PT1 | 64PT special –<br>PIC16C923/4,<br>PIC16C925/6 only | DVA-68PL2                         |
| XLT64PT2 | 64PT   | DVA-68PL                          |
| XLT64PT3 |  |                                   |
| XLT64PT4 |  |                                   |
| XLT80PT  | 80PT   | DVA-84PL                          |

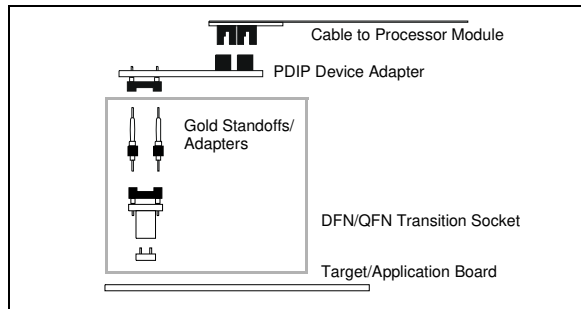
\* Refer to the “*Package Specification*” for PCB footprint dimensions (DS00049).  
 \*\* Refer to the processor module and device adapter specification for interface and dimensions to DVA/DAF (ICE 2000: “*MPLAB® ICE 2000 Processor Module and Device Adapter Specification*” (DS51140); ICE 4000: “*MPLAB® ICE 4000 Processor Module and Device Adapter Specification*” (DS51298)).

# Transition Socket Specification

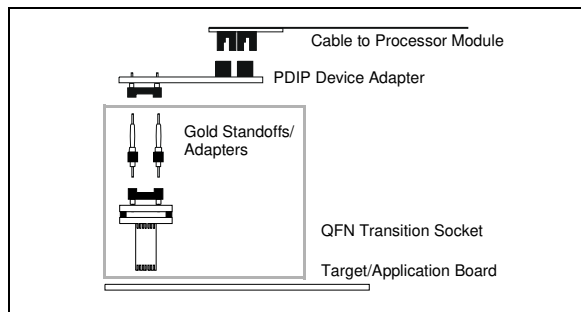
## SOT/DFN/QFN TRANSITION SOCKETS

SOT/DFN/QFN transition sockets and associated hardware are shown below.

**FIGURE 6: DFN/QFN TWO-PART TRANSITION SOCKET**



**FIGURE 7: QFN TRANSITION SOCKET**



The following SOT/DFN/QFN transition sockets have been discontinued:

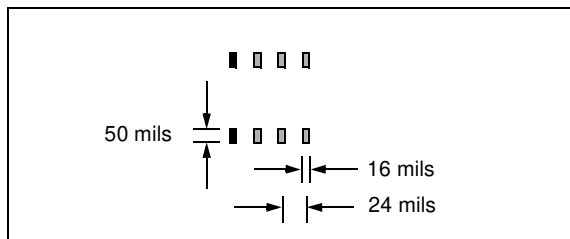
- XLT08DFN: One 8-lead DFN transition socket. (Replaced by XLT08DFN2.)
- XLT28QFN: One 28-lead QFN transition socket. (Replaced by XLT28QFN4.)
- XLT28QFN2: One 28-lead QFN transition socket. (Replaced by XLT28QFN3.)
- XLT44QFN: One 44-lead QFN two-part transition socket. (Replaced by XLT44QFN2.)

See the drawings in this section for layout dimensions.

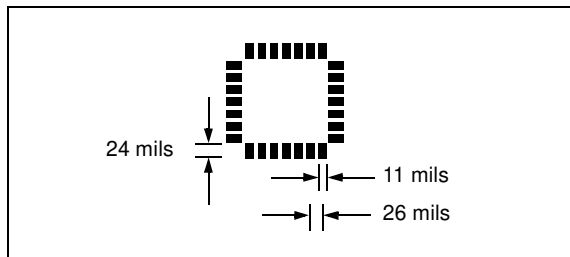
## RECOMMENDED PCB LAYOUT

The recommended target board footprint layout for different pin-counts is shown here.

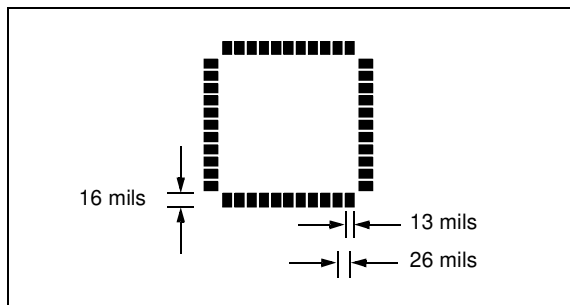
**FIGURE 8: 8-PIN DFN**



**FIGURE 9: 28-PIN QFN**



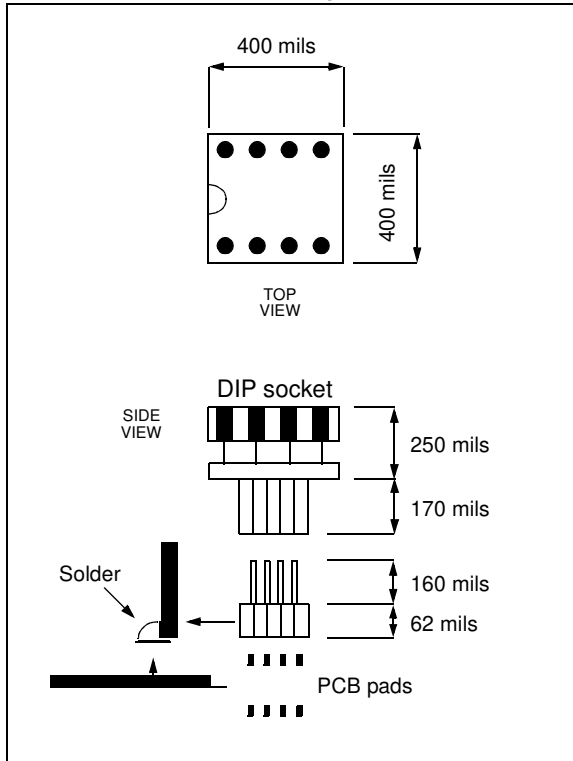
**FIGURE 10: 44-PIN QFN**



# Transition Socket Specification

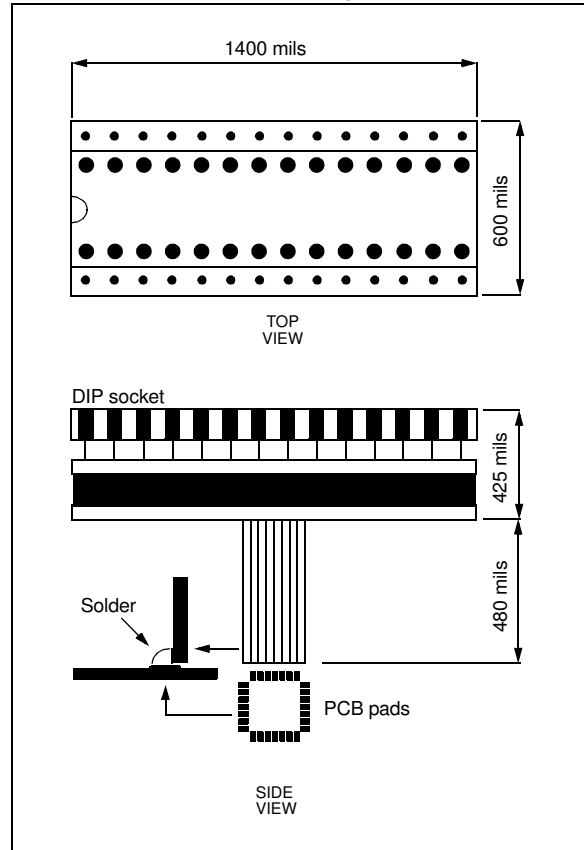
## XLT08DFN (Discontinued – see XLT08DFN2)

### 8-lead DIP to 0.025-inch Adapter Socket



## XLT28QFN (Discontinued – see XLT28QFN4)

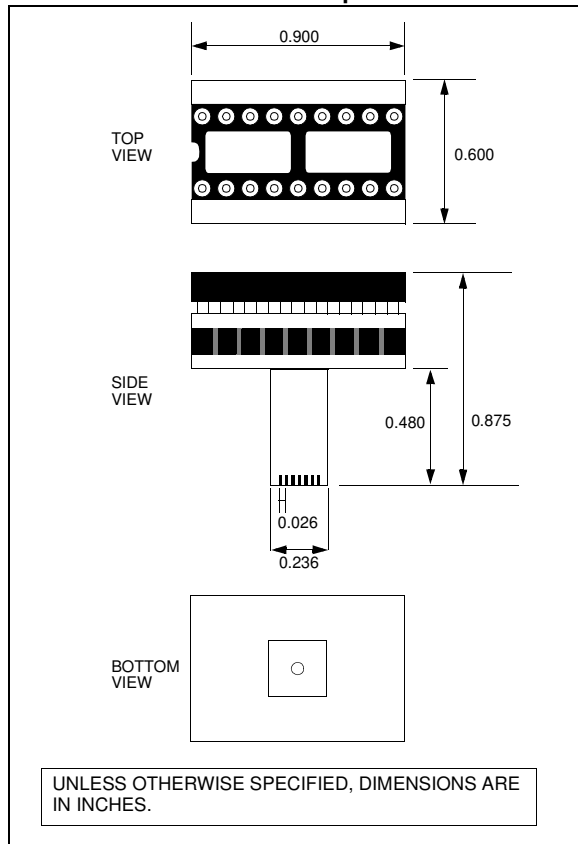
### 28-lead DIP to 0.025-inch Adapter Socket



# Transition Socket Specification

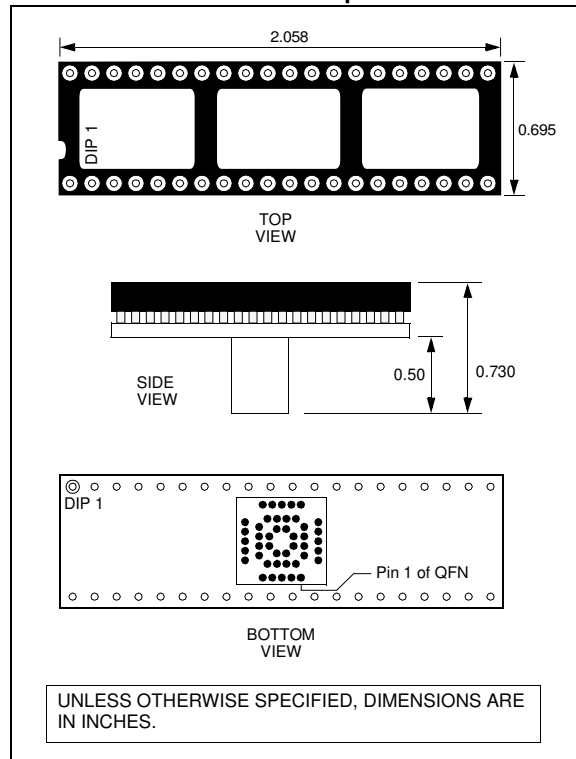
## XLT28QFN2 (Discontinued – see XLT28QFN3)

### 18-lead DIP to 0.025-inch Adapter Socket

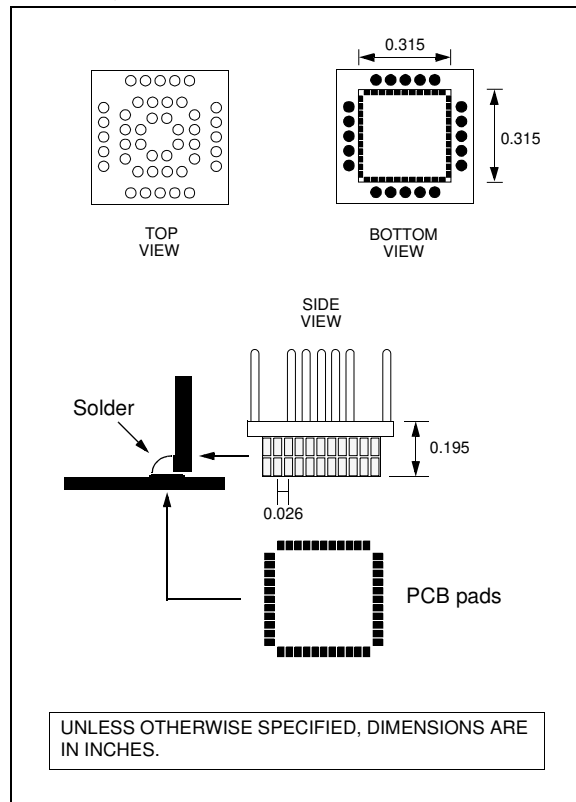


## XLT44QFN (Discontinued – see XLT44QFN2)

### 40-lead DIP to 0.025-inch Adapter Socket



### 44-lead QFN Header





# Transition Socket Specification

---

## APPENDIX A: REVISION HISTORY

### A.1 Revision N (February 2006)

The following is a list of modifications:

1. Added Appendix A: Revision History.
2. Removed "Preliminary" from the document's footer.
3. Added notes referring user to the "*Packaging Specification*" (DS00049) for PCB footprint dimensions in the "Two-Part QFP Sockets" section.

### A.2 Revision P (September 2006)

The following is a list of modifications:

1. Removed "MPLAB ICE 2000/4000" from the name of the document. This document now applies to multiple tools, and the document title was renamed to reflect this.
2. Updated document to reflect support of 4 tools.
3. Updated document to include break-away tab information for XLT64PT1, XLT64PT2 and XLT80PT.

### A.3 Revision Q (July 2008)

The following is a list of modifications:

1. Update for new SOIC, SSOP and QFN sockets.

### A.4 Revision R (July 2009)

The following is a list of modifications:

1. Updated the first paragraph in the "**Introduction**" section.

### A.5 Revision S (March 2010)

The following is a list of modifications:

1. Obsoleted XLT28XP and XLT64PT4
2. Added XLT44QFN4 and XLT44QFN5.



## WORLDWIDE SALES AND SERVICE

### AMERICAS

#### Corporate Office

2355 West Chandler Blvd.  
Chandler, AZ 85224-6199  
Tel: 480-792-7200  
Fax: 480-792-7277  
Technical Support:  
<http://support.microchip.com>  
Web Address:  
[www.microchip.com](http://www.microchip.com)

#### Atlanta

Duluth, GA  
Tel: 678-957-9614  
Fax: 678-957-1455

#### Boston

Westborough, MA  
Tel: 774-760-0087  
Fax: 774-760-0088

#### Chicago

Itasca, IL  
Tel: 630-285-0071  
Fax: 630-285-0075

#### Cleveland

Independence, OH  
Tel: 216-447-0464  
Fax: 216-447-0643

#### Dallas

Addison, TX  
Tel: 972-818-7423  
Fax: 972-818-2924

#### Detroit

Farmington Hills, MI  
Tel: 248-538-2250  
Fax: 248-538-2260

#### Kokomo

Kokomo, IN  
Tel: 765-864-8360  
Fax: 765-864-8387

#### Los Angeles

Mission Viejo, CA  
Tel: 949-462-9523  
Fax: 949-462-9608

#### Santa Clara

Santa Clara, CA  
Tel: 408-961-6444  
Fax: 408-961-6445

#### Toronto

Mississauga, Ontario,  
Canada  
Tel: 905-673-0699  
Fax: 905-673-6509

### ASIA/PACIFIC

#### Asia Pacific Office

Suites 3707-14, 37th Floor  
Tower 6, The Gateway  
Harbour City, Kowloon  
Hong Kong  
Tel: 852-2401-1200  
Fax: 852-2401-3431

#### Australia - Sydney

Tel: 61-2-9868-6733  
Fax: 61-2-9868-6755

#### China - Beijing

Tel: 86-10-8528-2100  
Fax: 86-10-8528-2104

#### China - Chengdu

Tel: 86-28-8665-5511  
Fax: 86-28-8665-7889

#### China - Chongqing

Tel: 86-23-8980-9588  
Fax: 86-23-8980-9500

#### China - Hong Kong SAR

Tel: 852-2401-1200  
Fax: 852-2401-3431

#### China - Nanjing

Tel: 86-25-8473-2460  
Fax: 86-25-8473-2470

#### China - Qingdao

Tel: 86-532-8502-7355  
Fax: 86-532-8502-7205

#### China - Shanghai

Tel: 86-21-5407-5533  
Fax: 86-21-5407-5066

#### China - Shenyang

Tel: 86-24-2334-2829  
Fax: 86-24-2334-2393

#### China - Shenzhen

Tel: 86-755-8203-2660  
Fax: 86-755-8203-1760

#### China - Wuhan

Tel: 86-27-5980-5300  
Fax: 86-27-5980-5118

#### China - Xian

Tel: 86-29-8833-7252  
Fax: 86-29-8833-7256

#### China - Xiamen

Tel: 86-592-2388138  
Fax: 86-592-2388130

#### China - Zhuhai

Tel: 86-756-3210040  
Fax: 86-756-3210049

### ASIA/PACIFIC

#### India - Bangalore

Tel: 91-80-3090-4444  
Fax: 91-80-3090-4123

#### India - New Delhi

Tel: 91-11-4160-8631  
Fax: 91-11-4160-8632

#### India - Pune

Tel: 91-20-2566-1512  
Fax: 91-20-2566-1513

#### Japan - Yokohama

Tel: 81-45-471- 6166  
Fax: 81-45-471-6122

#### Korea - Daegu

Tel: 82-53-744-4301  
Fax: 82-53-744-4302

#### Korea - Seoul

Tel: 82-2-554-7200  
Fax: 82-2-558-5932 or  
82-2-558-5934

#### Malaysia - Kuala Lumpur

Tel: 60-3-6201-9857  
Fax: 60-3-6201-9859

#### Malaysia - Penang

Tel: 60-4-227-8870  
Fax: 60-4-227-4068

#### Philippines - Manila

Tel: 63-2-634-9065  
Fax: 63-2-634-9069

#### Singapore

Tel: 65-6334-8870  
Fax: 65-6334-8850

#### Taiwan - Hsin Chu

Tel: 886-3-6578-300  
Fax: 886-3-6578-370

#### Taiwan - Kaohsiung

Tel: 886-7-536-4818  
Fax: 886-7-536-4803

#### Taiwan - Taipei

Tel: 886-2-2500-6610  
Fax: 886-2-2508-0102

#### Thailand - Bangkok

Tel: 66-2-694-1351  
Fax: 66-2-694-1350

### EUROPE

#### Austria - Wels

Tel: 43-7242-2244-39  
Fax: 43-7242-2244-393

#### Denmark - Copenhagen

Tel: 45-4450-2828  
Fax: 45-4485-2829

#### France - Paris

Tel: 33-1-69-53-63-20  
Fax: 33-1-69-30-90-79

#### Germany - Munich

Tel: 49-89-627-144-0  
Fax: 49-89-627-144-44

#### Italy - Milan

Tel: 39-0331-742611  
Fax: 39-0331-466781

#### Netherlands - Drunen

Tel: 31-416-690399  
Fax: 31-416-690340

#### Spain - Madrid

Tel: 34-91-708-08-90  
Fax: 34-91-708-08-91

#### UK - Wokingham

Tel: 44-118-921-5869  
Fax: 44-118-921-5820

01/05/10