

SPREAD SPECTRUM CLOCK GENERATOR
ICS7151A-50
Description

The ICS7151A-50 is a clock generator for EMI (Electromagnetic Interference) reduction. Spectral peaks are attenuated by modulating the system clock frequency. Down or center spread profiles are selectable. Down spread will not exceed the maximum frequency of an unspread clock, and center spread does not change the average operating frequency of the system

IDT offers many other clocks for computers and computer peripherals. Consult IDT when you need to remove crystals and oscillators from your board.

Features

- Operating voltage of 3.3 V \pm 0.3 V
- Packaged in 8-pin SOIC
- Available in Pb (lead) free package
- Input frequency range of 16.5 to 33.4 MHz
- Output frequency ranges of 8.3 to 16.7 MHz
- Provides a spread spectrum clock output (\pm 0.5%, \pm 1.5% center spread; -1.0%, -3.0% down spread)
- Multiplication rate of x1/2
- Advanced, low-power CMOS process
- Pin compatible with the Fujitsu MB88151-500

NOTE: EOL for non-green parts to occur on 5/13/10 per PDN U-09-01

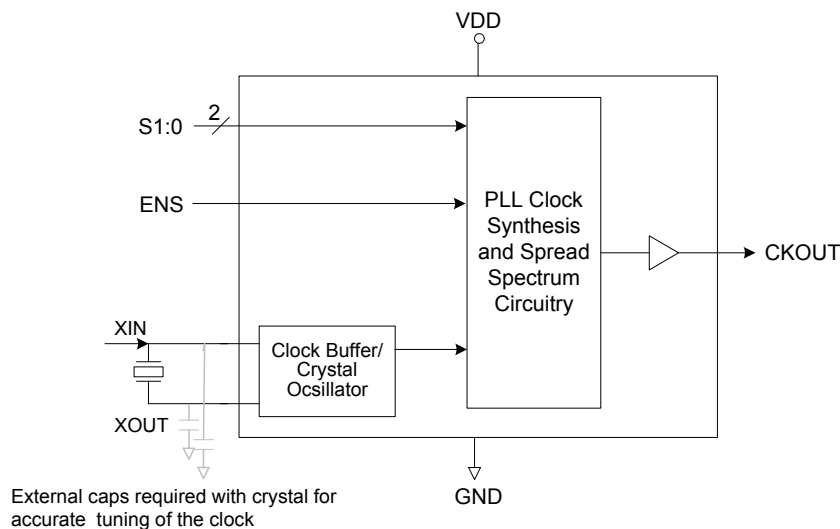
Block Diagram

Pin Assignment

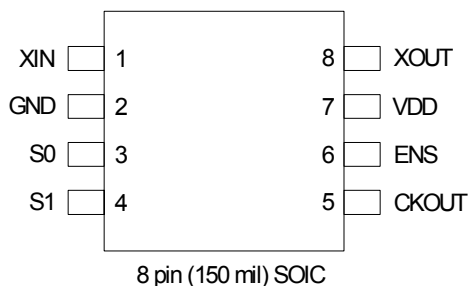

Spread Direction and Percentage Select Table

S1 Pin 4	S0 Pin 3	Spread Direction	Spread Percentage (%)
0	0	Center	±1.5
0	1	Center	±0.5
1	0	Down	-1.0
1	1	Down	-3.0
ENS (note 1)		Modulation	
0		No Modulation	
1		Modulation	

Notes:

- Pin 1 has a pull-up resistor.

Pin Descriptions

Pin Number	Pin Name	Pin Type	Pin Description
1	XIN	Input	Crystal pin/clock input pin.
2	GND	Power	Connect to ground.
3	S0	Input	Select pin 0. Spread modulation select.
4	S1	Input	Select pin 1. Spread modulation select.
5	CKOUT	Output	Clock output.
6	ENS	Input	Modulation enable. Internal pull-up resistor.
7	VDD	Power	Connect to +3.3 V.
8	XOUT	Output	Crystal connection pin.

External Components

The ICS7151A-50 requires a minimum number of external components for proper operation.

Decoupling Capacitor

A decoupling capacitor of 0.01 μ F must be connected between GND and VDD on pins 2 and 7, as close to these pins as possible. For optimum device performance, the decoupling capacitor should be mounted on the component side of the PCB. Avoid the use of vias in the decoupling circuit.

Series Termination Resistor

Series termination should be used on the clock output. To series terminate a 50 Ω trace (a commonly used trace impedance) place a 27 Ω resistor in series with the clock line, as close to the clock output pin as possible. The nominal impedance of the clock output is 25 Ω .

PCB Layout Recommendations

For optimum device performance and lowest output phase noise, the following guidelines should be observed.

- 1) The 0.01 μ F decoupling capacitor should be mounted on the component side of the board as close to the VDD pin as possible. No vias should be used between the decoupling capacitor and VDD pin. The PCB trace to VDD pin should be kept as short as possible, as should the PCB trace to the ground via.
- 2) To minimize EMI, the 27 Ω series termination resistor (if needed) should be placed close to the clock output.
- 3) An optimum layout is one with all components on the same side of the board, minimizing vias through other signal layers. Other signal traces should be routed away from the ICS7151A-50. This includes signal traces just underneath the device, or on layers adjacent to the ground plane layer used by the device.

Crystal Information

The crystal used should be a fundamental mode (do not use third overtone), parallel resonant. Crystal capacitors should be connected from pins X1 to ground and X2 to ground to optimize the initial accuracy. The value of these capacitors is given by the following equation:

$$\text{Crystal caps (pF)} = (C_L - 6) \times 2$$

In the equation, C_L is the crystal load capacitance. So, for a crystal with a 16 pF load capacitance, two 20 pF [(16-6) x 2] capacitors should be used.

Spread Spectrum Profile

The ICS7151A-50 low EMI clock generator uses a triangular frequency modulation profile for optimal down stream tracking of zero delay buffers and other PLL devices. The frequency modulation amplitude is constant with variations of the input frequency.

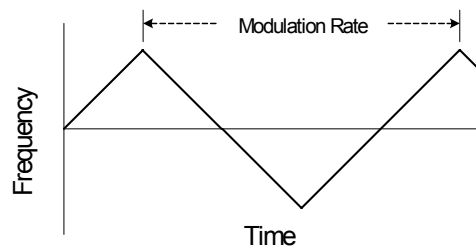

Absolute Maximum Ratings

Stresses above the ratings listed below can cause permanent damage to the ICS7151A-50. These ratings, which are standard values for IDT commercially rated parts, are stress ratings only. Functional operation of the device at these or any other conditions above those indicated in the operational sections of the specifications is not implied. Exposure to absolute maximum rating conditions for extended periods can affect product reliability. Electrical parameters are guaranteed only over the recommended operating temperature range.

Item	Rating
Supply Voltage, VDD	-0.5 to 4.0 V
All Inputs and Outputs (referenced to GND)	-0.5 V to VDD+0.5 V
Ambient Operating Temperature	-40 to +85° C
Storage Temperature	-55 to +125° C
Junction Temperature	-40 to +125° C
Soldering Temperature	260° C
Overshoot (V_{IOVER})	VDD + 1.0 V ($t_{OVER} \leq 50$ ns)
Undershoot (V_{IUNDER})	GND - 1.0 V ($t_{UNDER} \leq 50$ ns)

Overshoot/Undershoot

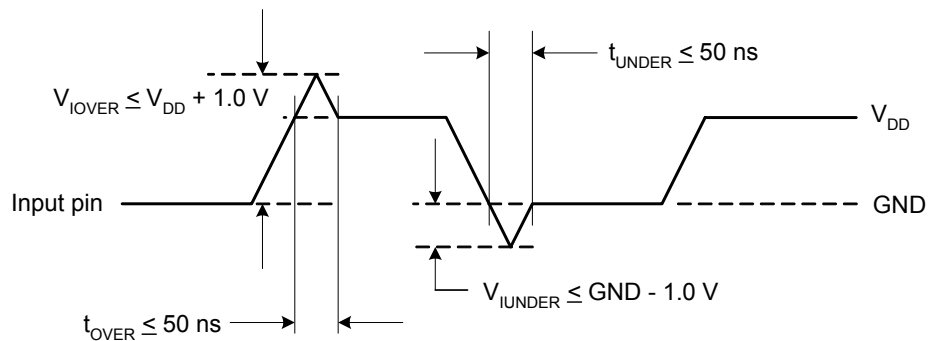

Recommended Operation Conditions

Parameter	Min.	Typ.	Max.	Units
Ambient Operating Temperature	-40		+85	°C
Power Supply Voltage (measured in respect to GND)	+3.0	3.3	3.6	V

DC Electrical Characteristics

Unless stated otherwise, $V_{DD} = 3.3\text{ V} \pm 0.3\text{ V}$, Ambient Temperature -40 to $+85^\circ\text{C}$

Parameter	Symbol	Conditions	Min.	Typ.	Max.	Units
Operating Voltage	VDD		3.0	3.3	3.6	V
Supply Current	IDD	No load, at 3.3 V, output = 24 MHz		10	14	mA
Input Frequency			16.5		33.4	MHz
Input High Voltage	V _{IH}	XIN, S0, S1, ENS	VDD * 0.8		VDD + 0.3	V
Input Low Voltage	V _{IL}	XIN, S0, S1, ENS	0.0		VDD * 0.20	V
Output High Voltage	V _{OH}	CKOUT, I _{OH} = -4 mA	2.0			V
Output Low Voltage	V _{OL}	CKOUT, I _{OL} = 4 mA			0.4	V
Input Capacitance	C _{IN}	XIN, S0, S1, ENS			16	pF
Load Capacitance	C _L	CKOUT, 8.3 to 66.7 MHz			15	pF
		CKOUT, 66.7 to 100 MHz			10	pF
		CKOUT, 100 to 133.4 MHz			7	pF
Input Pull-up Resistor	R _{PU}	ENS	100	240	400	k Ω

AC Electrical Characteristics

Unless stated otherwise, $V_{DD} = 3.3\text{ V} \pm 0.3\text{ V}$, Ambient Temperature -40 to $+85^\circ\text{C}$

Parameter	Symbol	Conditions	Min.	Typ.	Max.	Units
Oscillation Frequency	f _X	Fundamental oscillation	16.5		33.4	MHz
Input Frequency	f _{IN}	XIN	16.5		33.4	MHz
Output Frequency	f _{OUT}	CKOUT, 2-frequency division	8.3		16.7	MHz
Input Clock Duty Cycle		XIN, 16.5 to 33.4 MHz	40	50	60	%
Output Clock Duty Cycle	t _{DCC}	CKOUT, 1.5 V	40		60	%
Output Slew Rate		CKOUT, 0.4 to 2.4 V, load capacitance 15 pF	0.5	TBD	3.0	V/ns
Cycle to Cycle Jitter	t _{JC}	No load, standard deviation		TBD	200	ps
Lock Time	t _{LK}	CKOUT		2	5	ms
Modulation Frequency	f _{MOD}	CKOUT=TBD		33		kHz

Input Frequency ($f_{IN} = 1/t_{IN}$)

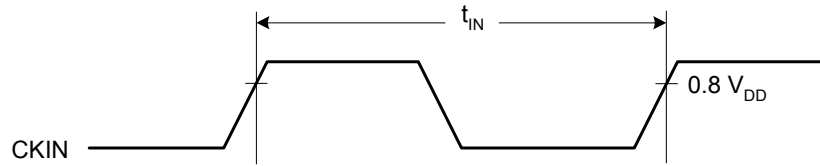

Output Slew Rate

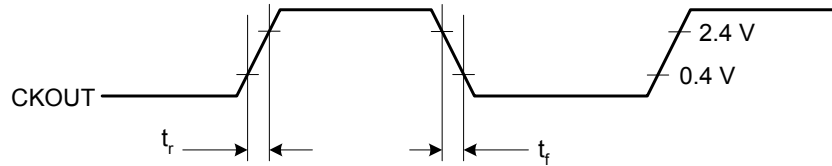

$$SR = (2.4 - 0.4) / t_r, SR = (2.4 - 0.4) / t_f$$

Thermal Characteristics

Parameter	Symbol	Conditions	Min.	Typ.	Max.	Units
Thermal Resistance Junction to Ambient	θ_{JA}	Still air		150		$^{\circ}C/W$
	θ_{JA}	1 m/s air flow		140		$^{\circ}C/W$
	θ_{JA}	3 m/s air flow		120		$^{\circ}C/W$
Thermal Resistance Junction to Case	θ_{JC}			40		$^{\circ}C/W$

Package Outline and Package Dimensions (8-pin SOIC, 150 Mil. Body)

Package dimensions are kept current with JEDEC Publication No. 95

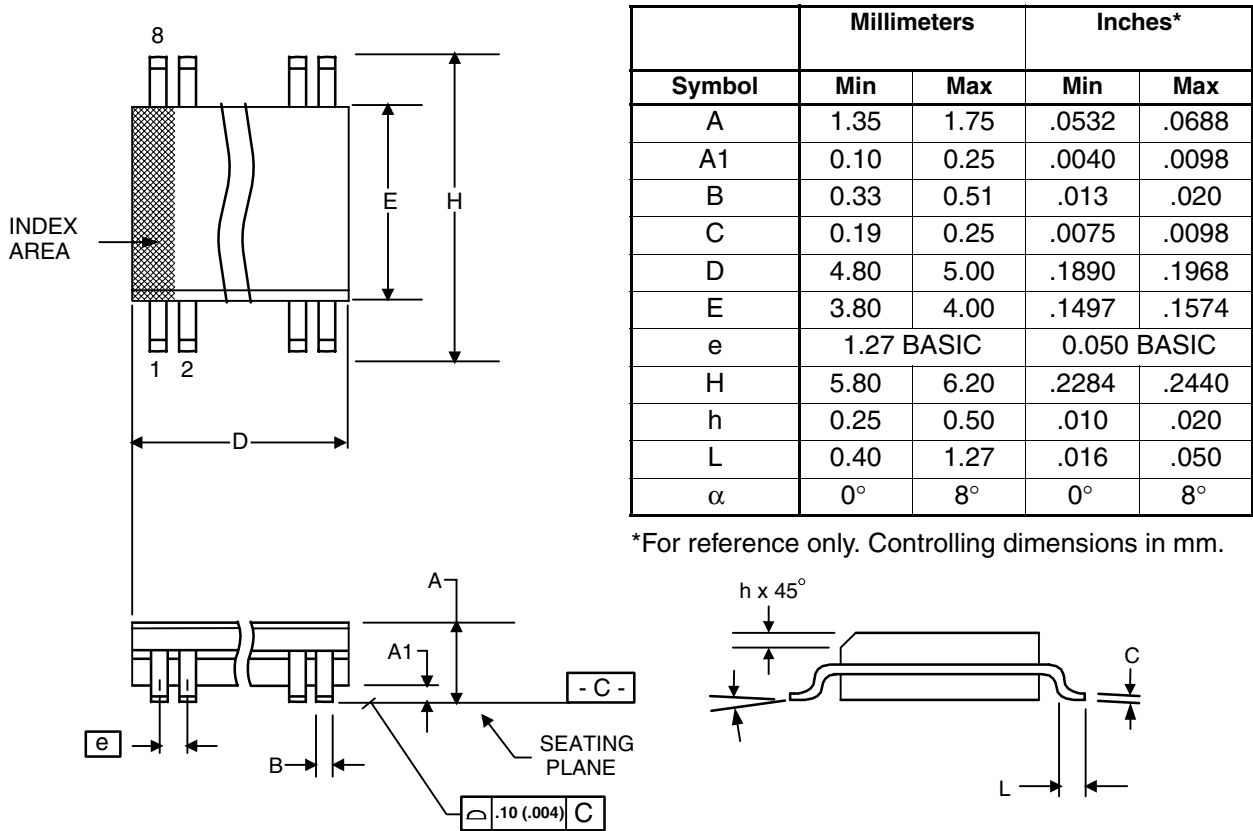

*Ordering Information

Part / Order Number	Marking	Shipping Packaging	Package	Temperature
7151AM-50*	7151AM50	Tubes	8-pin SOIC	0 to +70° C
7151AM-50T*	7151AM50	Tape and Reel	8-pin SOIC	0 to +70° C
7151AM-50LF	151AM50L	Tubes	8-pin SOIC	0 to +70° C
7151AM-50LFT	151AM50L	Tape and Reel	8-pin SOIC	0 to +70° C
7151AMI-50*	151AMI50	Tubes	8-pin SOIC	-40 to +85° C
7151AMI-50T*	151AMI50	Tape and Reel	8-pin SOIC	-40 to +85° C
7151AMI-50LF	51AMI50L	Tubes	8-pin SOIC	-40 to +85° C
7151AMI-50LFT	51AMI50L	Tape and Reel	8-pin SOIC	-40 to +85° C

NOTE: EOL for non-green parts to occur on 5/13/10 per PDN U-09-01

Parts that are ordered with a "LF" suffix to the part number are the Pb-Free configuration and are RoHS compliant.

While the information presented herein has been checked for both accuracy and reliability, Integrated Device Technology (IDT) assumes no responsibility for either its use or for the infringement of any patents or other rights of third parties, which would result from its use. No other circuits, patents, or licenses are implied. This product is intended for use in normal commercial applications. Any other applications such as those requiring extended temperature range, high reliability, or other extraordinary environmental requirements are not recommended without additional processing by IDT. IDT reserves the right to change any circuitry or specifications without notice. IDT does not authorize or warrant any IDT product for use in life support devices or critical medical instruments.

Revision History

Rev.	Originator	Date	Description of Change
A	J. Sarma	10/20/05	Rev A; new device/datasheet.
B		11/04/09	Added EOL note for non-green parts.

Innovate with IDT and accelerate your future networks. Contact:

www.IDT.com

For Sales

800-345-7015
408-284-8200
Fax: 408-284-2775

For Tech Support

www.idt.com/go/clockhelp

Corporate Headquarters

Integrated Device Technology, Inc.
www.idt.com



www.IDT.com