

MATERIALS & SPECIFICATIONS

PART NO.	A28400-025	REV	ECO	DATE	APP
		J	102438	03-16-16	TLM

HOUSING:
ALUMINUM 6061-T6, NICKEL PLATE PER
SAE-AMS-2404

INSULATOR:
LIQUID CRYSTAL POLYMER (LCP) PER
ASTM D5138

CONTACT:
BERYLLIUM COPPER PER ASTM B194,
C17200, GOLD PLATED PER ASTM B488,
(HARD GOLD) TYPE II CODE C, CLASS
1.27

TERMINATION:
SOLDER COATED WITH SN63A PER
J-STD-006 OR AMS-P-81728

CURRENT RATING:
1 AMP MAX PER MIL-DTL-32139

CONTACT RESISTANCE:
71 MILLIOHM MAX (71mV DROP MAX) @
1.0 AMPS PER MIL-DTL-32139

PERFORMANCE:
PRODUCT FAMILY TESTED TO AND PASSED
THE PERFORMANCE SPECIFICATIONS OF
TABLE VIII OF MIL-DTL-32139

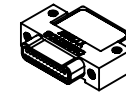
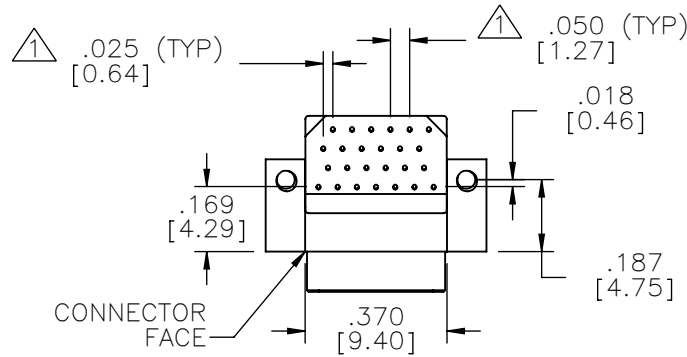

ACTUAL SIZE

φ.010±.002 (TYP)
[0.25±0.05]
SOLDER COATED

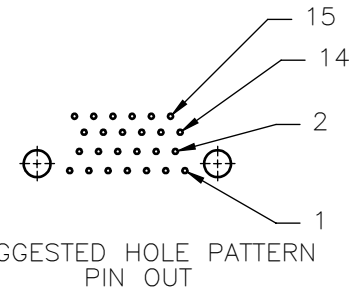
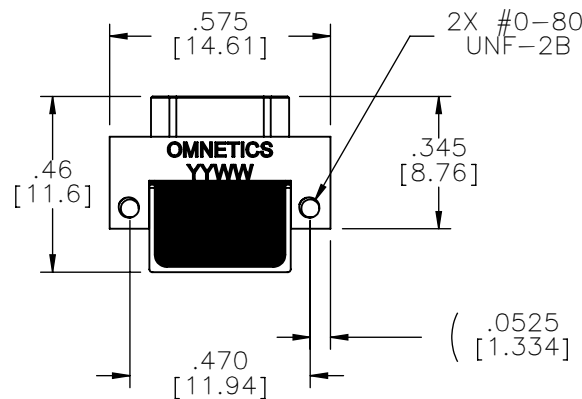
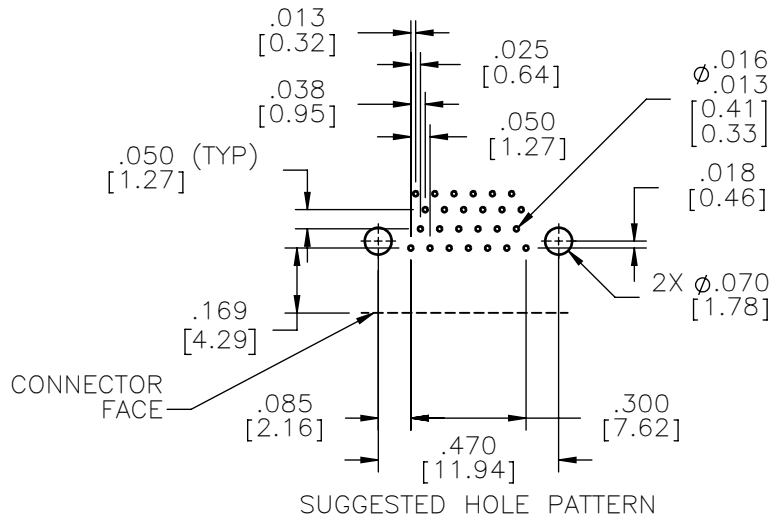
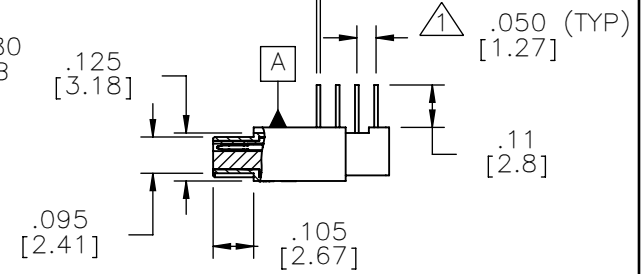
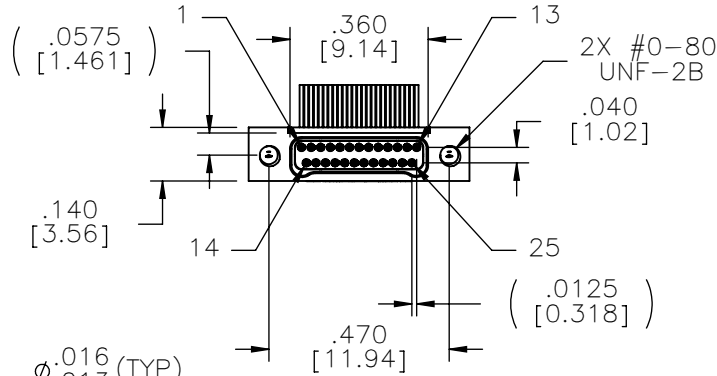

△ TAIL DIMENSIONS APPLY AT PLANE A

NOTE:

DIMENSIONS IN [] ARE IN
MILLIMETERS UNLESS
OTHERWISE NOTED AND ARE
FOR REFERENCE ONLY

MFG DATE	THIRD ANGLE
	- TOLERANCES -
	UNLESS OTHERWISE NOTED
	DIMENSIONS IN INCHES
2	PL DEC ± .01
3	PL DEC ± .005
4	PL DEC ± .0005
	ANGLES ± 1°

THIS DRAWING CONTAINS CONFIDENTIAL AND PROPRIETARY INFORMATION WHICH IS THE PROPERTY OF
OMNETICS CONNECTOR CORP. THIS DOCUMENT MAY NOT, IN WHOLE OR IN PART, BE DUPLICATED, OR
DISCLOSED FOR ANY PURPOSE, WITHOUT WRITTEN PERMISSION FROM OMNETICS CONNECTOR CORP.

DFTM.	TLM	DATE	05-01-06
CHK'D.		DATE	
APP'D.		DATE	

TITLE:
(25) PIN MALE
Bi-Lobe® CONNECTOR

OMNETICS
CONNECTOR CORPORATION
7260 COMMERCE CIRCLE EAST
MINNEAPOLIS, MN 55432
WWW.OMNETICS.COM

CAGE CODE	61873
DWG NO.	A28400-025
SHEET 1 OF 1	REV J
SCALE:	2:1