

THIS DRAWING IS UNPUBLISHED.
 VERTRÄGLICHE UNVERÖFFENTLICHTE ZEICHNUNG
 (C) COPYRIGHT 2021 TE Connectivity Germany GmbH
 RELEASED FOR PUBLICATION
 FREI FÜR VERÖFFENTLICHUNG
 2021
 ALL RIGHTS RESERVED.
 ALLE RECHTE VORBEHALTEN.

PROJECT NO.:
 PRJ-21-000902851

REVISIONS				
P	LTR	DESCRIPTION	DATE	APVD
1		NEW PELIMINARY DRAWING	11MAY2021	NM JDB
A		GTP ECN-21-106099	14 JUN2021	NM JDB

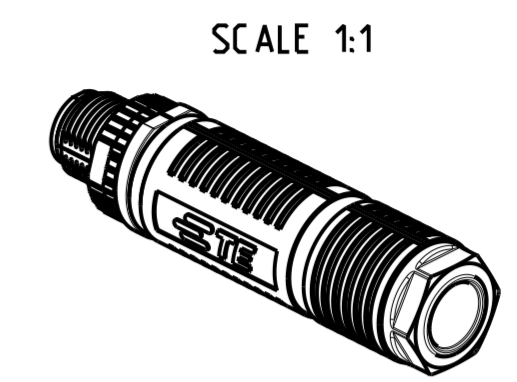
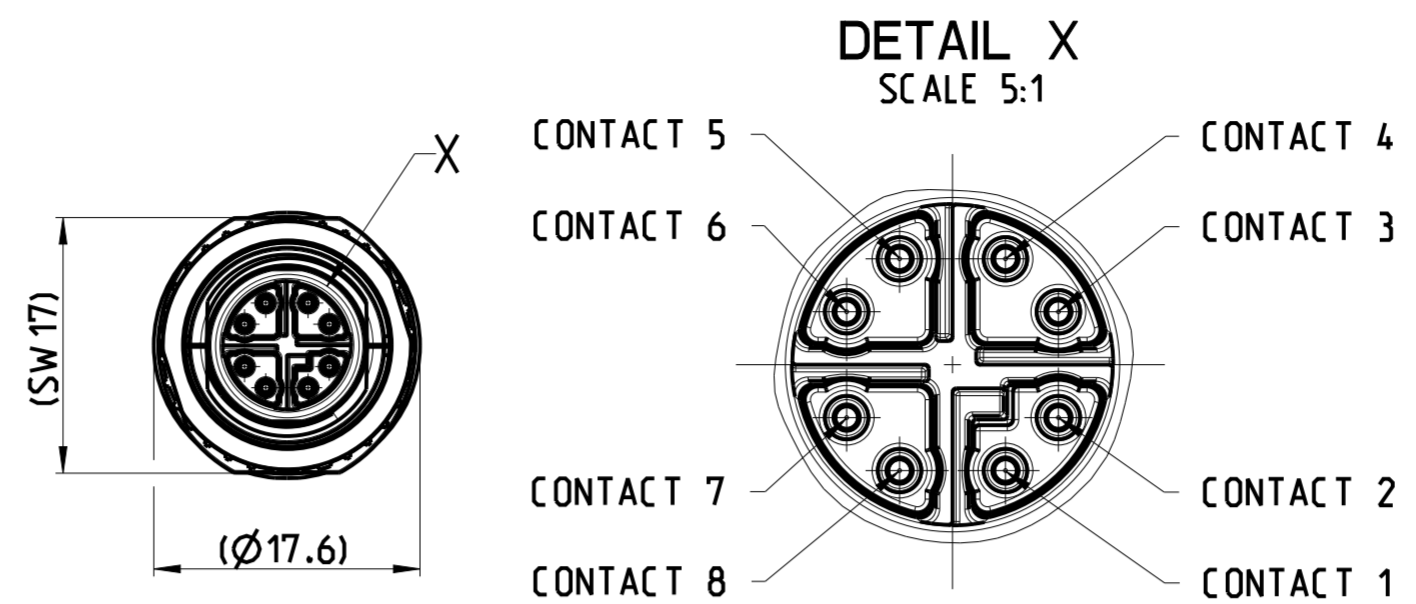
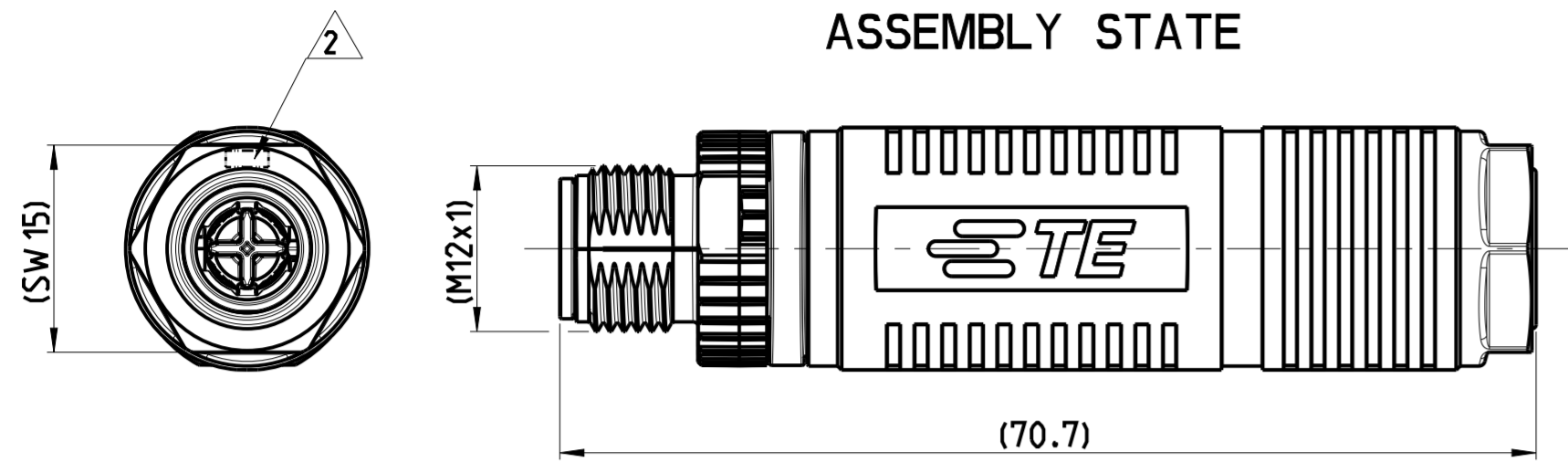

DELIVERY STATE

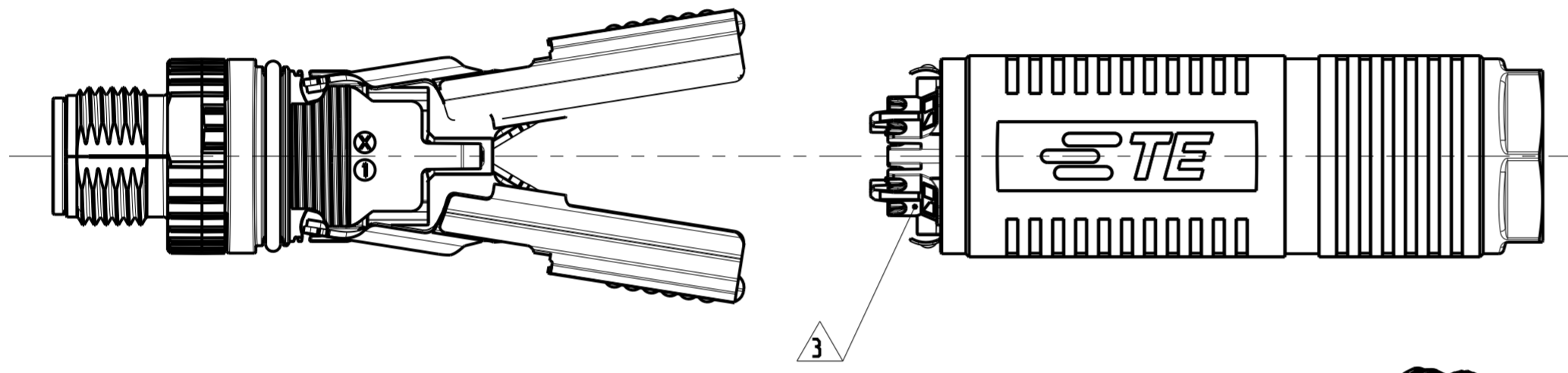

- 2 MANUFACTURING DATE CODE MARKING:
YEAR AND WEEK (SEE TABLE)
AFTER POSITIVE INSPECTION
- 3 FLOATING POSITION
- 4 PACKAGING: 1 PIECE OF EACH COMPONENT
PACKED IN A FOLDING CARTON
WITH A INSTRUCTION SHEET
- 6 APPLICATION SEE INSTRUCTION SHEET 408-18019

CABLE: 8 POS. AWG 24 AND AWG 26
 STRANDED OR SOLID

CABLE: 4 POS. AWG 22 STRANDED OR SOLID

RECOMMENDED STRIPPING LENGTH

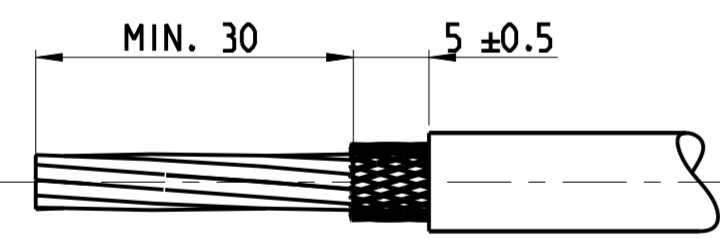

RECOMMENDED STRIPPING LENGTH

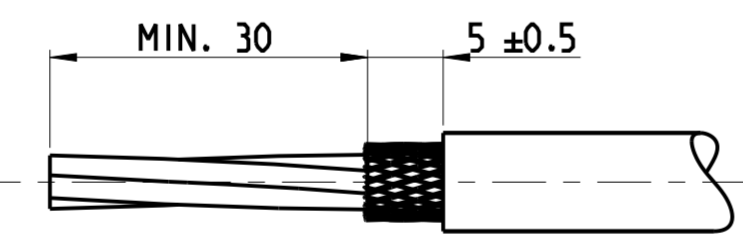

COLOR ALLOCATION OF
 M12 X-CODE CONTACT 8 POS. TYPE:

CONTACT NO.	COLOR CODE/ WIRE COLOR
1	WHITE/ORANGE
2	ORANGE
3	WHITE/GREEN
4	GREEN
5	WHITE/BROWN
6	BROWN
7	WHITE/BLUE
8	BLUE

COLOR ALLOCATION OF
 M12 X-CODE CONTACT 4 POS. TYPE:

CONTACT NO.	COLOR CODE	WIRE COLOR (PROFINET 4P)
1	WHITE/ORANGE	YELLOW
2	ORANGE	ORANGE
3	WHITE/GREEN	WHITE
4	GREEN	BLUE

PRODUCTION DATE CODE

YEAR	CODE	WEEK
2018	K	01
2019	L	T0
2020	M	52
2021	N	
2022	P	
2023	R	

EXAMPLES: WEEK 22 IN 2018 = K22
 WEEK 3 IN 2020 = M03

TOLERANCING ISO 8015
 GEOMETRIC TOLERANCING ISO 1101
 SIZE ISO 14405
 GENERAL TOLERANCES ISO 2768-K

- 1 AS SHOWN

M12 X-CODE	2327989-1	1SET310625R0000
DESCRIPTION	TE PN	ENTRELEC PN

TE CONNECTIVITY
 ORDER-NO.

QUANTITY	DESCRIPTION	SURFACE COLOUR	MATERIAL
1	M12 X-CODE FIELD INSTALLABLE CABLE PLUG WITH INSTRUCTION SHEET	-	-

DIESE ZEICHNUNG IST EIN KONTROLLIERTES DOKUMENT.
 BEMASSUNGEN UND TOLERANZEN GEMAESS GPS (ISO STANDARDS).

THIS DRAWING IS A CONTROLLED DOCUMENT.
 DIMENSIONING AND TOLERANCING PER GPS (ISO STANDARDS).

APVD: N.MANTIKOU 11MAY2021
 CHK: T.LEININGER 11MAY2021
 J.D.BRIJIN 11MAY2021

PRODUCT SPEC: 108-94661
 APPLICATION SPEC: -

WEIGHT: -
 MATERIAL: -

ENTRELEC
 Electrical Solutions

NAME: M12 X-CODE CAT6a
 M12 X-CODE CAT6a

SIZE: A2 CAGE CODE: 00779 DRAWING NO.: G-1SET310625R0000

CUSTOMER DRAWING /KUNDENZEICHNUNG SCALE MASSSTAB: 2:1 SHEET BLATT: 1 OF 1 REV: A