

INTRODUCTION

The IoTa v1.0 is a fully open source reference design and prototyping platform for developers to rapidly test and move applications to market. The IoTa makes connectivity simple and enables embedded applications to access peripherals and sensors through an array of GPIO pins and serial interfaces. The on-board microcontrollers implement user and system functions separately for ease of development. Battery management includes charging and fuel gauge functions, making the IoTa ideal for low power applications. The IoTa ships with a Hologram SIM card for seamless cloud services integration, but other SIMs will also work. Check with POEM Technology for operation with other SIM providers.

MICROCONTROLLERS

System Microcontroller

The System microcontroller is Freescale's MKL17Z256VFM4 which features a 32-bit ARM Cortex-M0+ that runs at 48 MHz and has 256 kB Flash and 32 kB RAM. This microcontroller manages the u-blox modem as well as connections into Hologram's cloud.

- {} Open source System microcontroller firmware
- {} Datasheet for the MKL17Z256VFM4

User Microcontroller

The User microcontroller is Freescale's MK22FN1M0AVLH12 which features a 32-bit ARM Cortex-M4 that runs at 120MHz and has 1MB Flash and 256kB RAM. This microcontroller exclusively hosts user programs that are fully compatible with Arduino APIs. (Note: although the firmware is fully Arduino-compatible, when loading Arduino libraries on the IoTa, it is important to check the library for hardware-specific calls. In these cases these libraries will not be compatible with the IoTa out of the box.)

- {} Open source User microcontroller firmware
- {} Datasheet for the MK22FN1M0AVLH12
- {} Reference sheet for the MK22FN1M0AVLH12

OPEN SOURCE HARDWARE

POEM Technology is committed to provide open source hardware to developers seeking a field-tested and readily scalable reference design. Based on the original Hologram IoTa design, the IoTa has a new Open Source Hardware Association designation. It is the first OSHWA design to be recertified from a previous design.

The IoTa, as originally manufactured by Hologram, is certified by the OSHWA (Open Source Hardware Association) under identifier US000082. The new certification identifier is forthcoming. The new POEM Technology design can be modified and adapted to any application (commercial or otherwise). Please see the product pages for license information.

The IoTa Block Diagram and Pinout

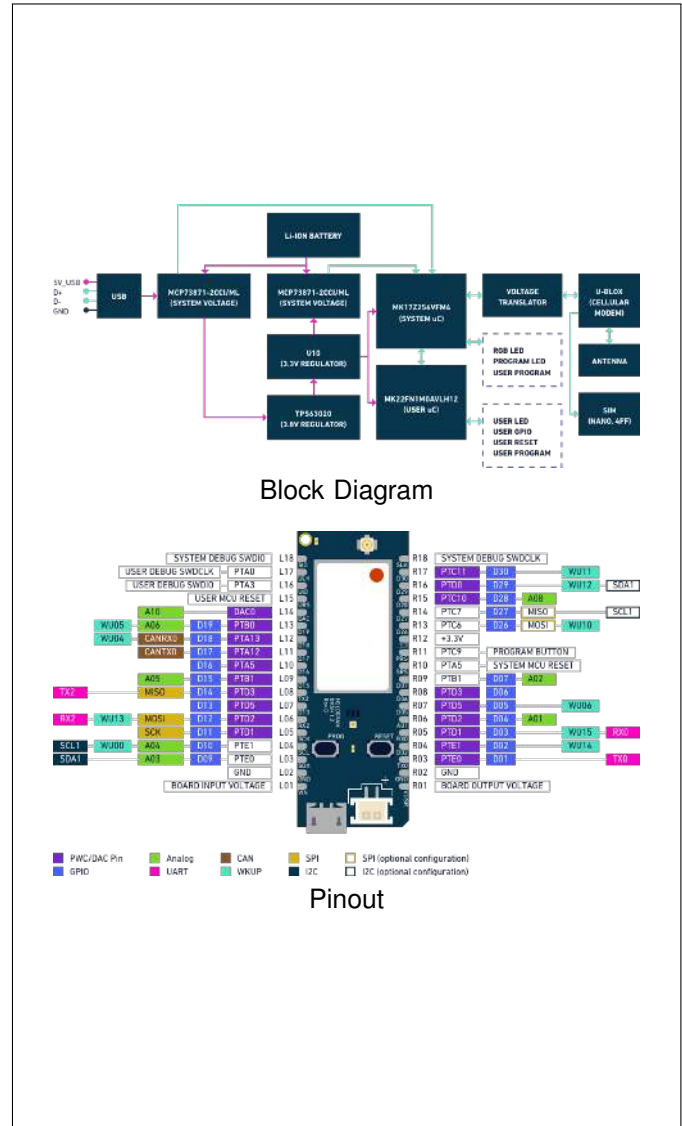

POWER INPUT/OUTPUT CHARACTERISTICS

The IoTa v1.0 can be powered using the USB_5V, VBATT, or SystemVin pins. The IoTa v1.0 can power other peripherals through the VSystem_User and 3.3V pins. Allowable minimum and maximum voltage and current for these power inputs and power outputs are listed below-Contact POEM Technology for solar-powered operation.

SYMBOL	DESCRIPTION	MIN	TYPICAL	MAX
USB_5V	USB 5V input	4.7	5V	5.25V / 2.1A
VBATT	Battery input	2.0V @ 0.1mA	4.2V	200mA
3.3V	3.3V output		3.3V	3.32V / 250mA
SystemVin	5V input	4.75V	5V	7V / 1.8A
VSystem_User	5V output			VSystem-.7* / 250mA**

*VSystem_User is a reference to the internal 5V power supply, protected by an input diode.
 ** Current draw by peripherals on this pin should be limited to 250mA to maintain normal operation of internal IoTa components.

PERIPHERALS AND GPIO

Peripherals and GPIO on the IoTa v1.0 minimum and maximum voltages are listed below. The IoTa user microcontroller works at 3.3V (i.e. 3.3V registers as a “1” for digital GPIO and analog input) and the digital pins are 5V tolerant whereas the analog pins are 4.1V tolerant.

FUNCTION	# OF PINS	INPUT/OUTP	MIN	MAX
DIGITAL GPIO	25	BOTH	-0.3	5.5V
ADC	10	INPUT	-0.3	4.1V
DAC	1	OUTPUT	0	3.3V
I2C	2	BOTH	-0.3	5.5V
UART	2	BOTH	-0.3	5.5V
SPI	2*	BOTH	-0.3	5.5V
CAN	1	BOTH	-0.3	5.5V

*Denotes single SPI with 2 configurations

MECHANICAL DIMENSIONS

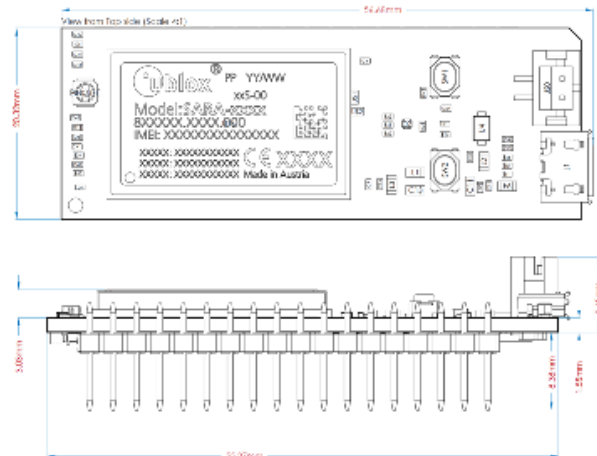

POWER MANAGEMENT

DEEP SLEEP

The IoTa has three different power operating modes that are configurable via API:

- Normal (default): Both microcontrollers are running at standard clock rates (48MHz and 120MHz for the System and User microcontrollers, respectively) and the u-blox modem is on. The User modem can be configured for 120MHz, 100MHz, or 48MHz.
- Sleep: Instruction clock is paused and peripherals and interrupts remain active.
- deepSleep: Lowest possible power mode on the IoTa. Most peripherals and interrupts are disabled, only select wake-up interrupts can wake from deepSleep (select I/O pins, alarm) when configured. The system microcontroller, user microcontroller, and u-blox modem can be placed into deepSleep independently. Current consumption in deepSleep is nominally 900µA.

BATTERY CHARGING

Battery charging is automatically managed by the MCP73871-2CCI/ML IC.

The details for the MCP73871-2CCI/ML can be found on the datasheet.

RADIO SPECIFICATIONS

The IoTa v1.0 features the global band SARA-R410M Cat-M/NB-IoT variant. The supported bands are:

1, 2, 3, 4, 5, 8, 12, 13, 17, 18, 19, 20, 25, 26, 28 (and band 39 in M1-only).

These bands correspond to Uplink and Downlink frequencies in the following ranges (in MHz):

700, 800, 850, 900, 1700, 1800, 1900, 2100

The full list of bands and frequencies can be found in the u-blox SARA datasheet.

LEDs and Buttons: The IoTa includes 3 different LEDs and two different buttons:

- Reset Button: Resets the user microcontroller.
- Program Button: used to put IoTa into programming mode.
- Program LED: flashes when the IoTa is in programming mode.



- User LED: full configurable by user programs using the Arduino IDE.



- RGB LED: configurable by user programs RGB LED.



Read more about configuring both User and RGB LEDs in our Dash API reference.