

### DESCRIPTION

The MP86965 is a monolithic half-bridge with built-in internal power MOSFETs and gate drivers. The MP86965 achieves 60A of continuous output current over a wide input supply range.

The device provides a monolithic IC approach that drives up to 60A of current per phase. Integrated drivers and MOSFETs offer high efficiency due to optimal dead time and reduced parasitic inductance. The MP86965 can operate from 100kHz to 2MHz.

The MP86965 offers many features to simplify system design. It works with controllers with tri-state PWM signals, and provides an accurate current sense to monitor inductor current and temperature sense to report the junction temperature.

The MP86965 is ideal for server applications where efficiency and small size are at a premium. It is available in a TLGA-31 (4mmx5mm) package.

### FEATURES

- Wide 4.5V to 16V Operating Input Range
- 60A Output Current
- Current Sense: Accu-Sense™
- Temperature Sense
- Accepts Tri-State PWM Signal
- Current Limit Protection
- Over-Temperature Protection (OTP)
- Fault Reporting
- Available in a TLGA-31 (4mmx5mm) Package

### APPLICATIONS

- Server Core Voltage
- Graphics Card Core Regulators
- Power Modules

All MPS parts are lead-free, halogen-free, and adhere to the RoHS directive. For MPS green status, please visit the MPS website under Quality Assurance. "MPS", the MPS logo, and "Simple, Easy Solutions" are trademarks of Monolithic Power Systems, Inc. or its subsidiaries.

### TYPICAL APPLICATION

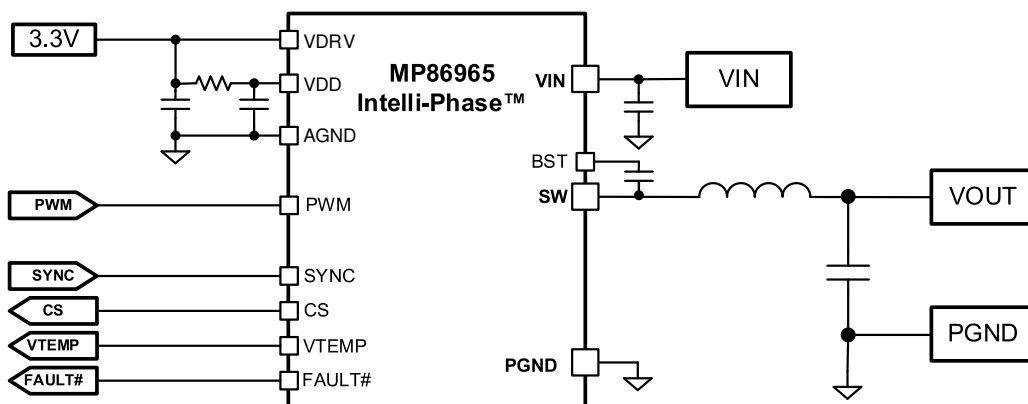

**Notice:** The information in this document is subject to change without notice. Please contact MPS for current specifications. Users should warrant and guarantee that third-party Intellectual Property rights are not infringed upon when integrating MPS products into any application. MPS will not assume any legal responsibility for any said applications.