

THIS DRAWING IS UNPUBLISHED. RELEASED FOR PUBLICATION 2003  
 (C) COPYRIGHT 2003 ALL RIGHTS RESERVED.

LOC	DIST	REVISIONS					
A	I	P	LTR	DESCRIPTION	DATE	DWH	APVD
		B		ECR-12-002845	17APR2012	MKD	RRP
		B1		ECR-14-006224	28APR2014	KD	BW

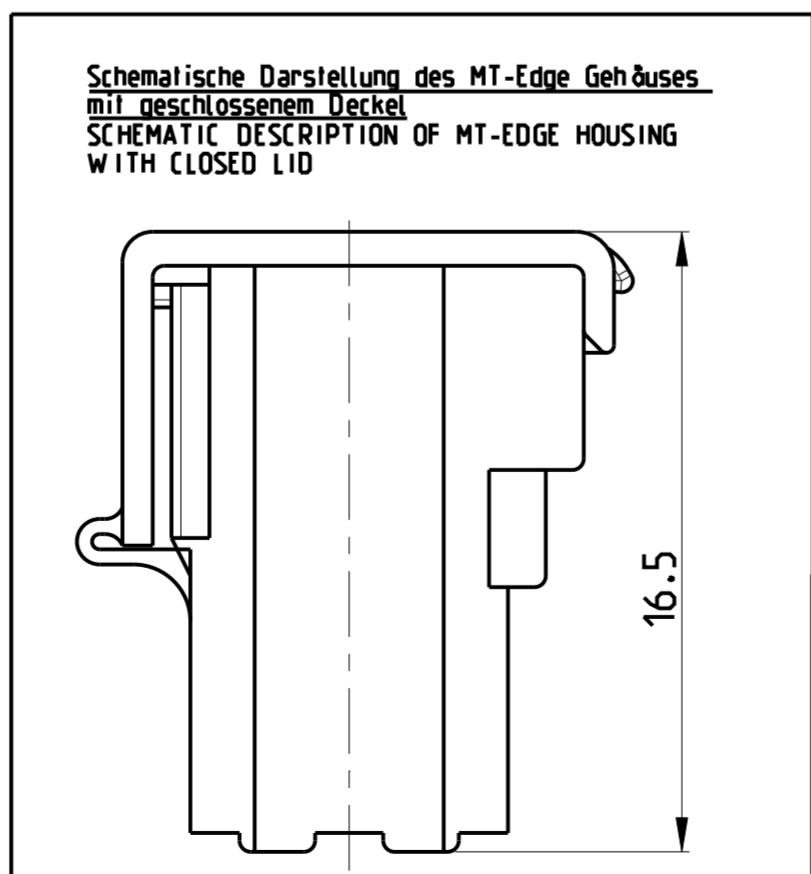
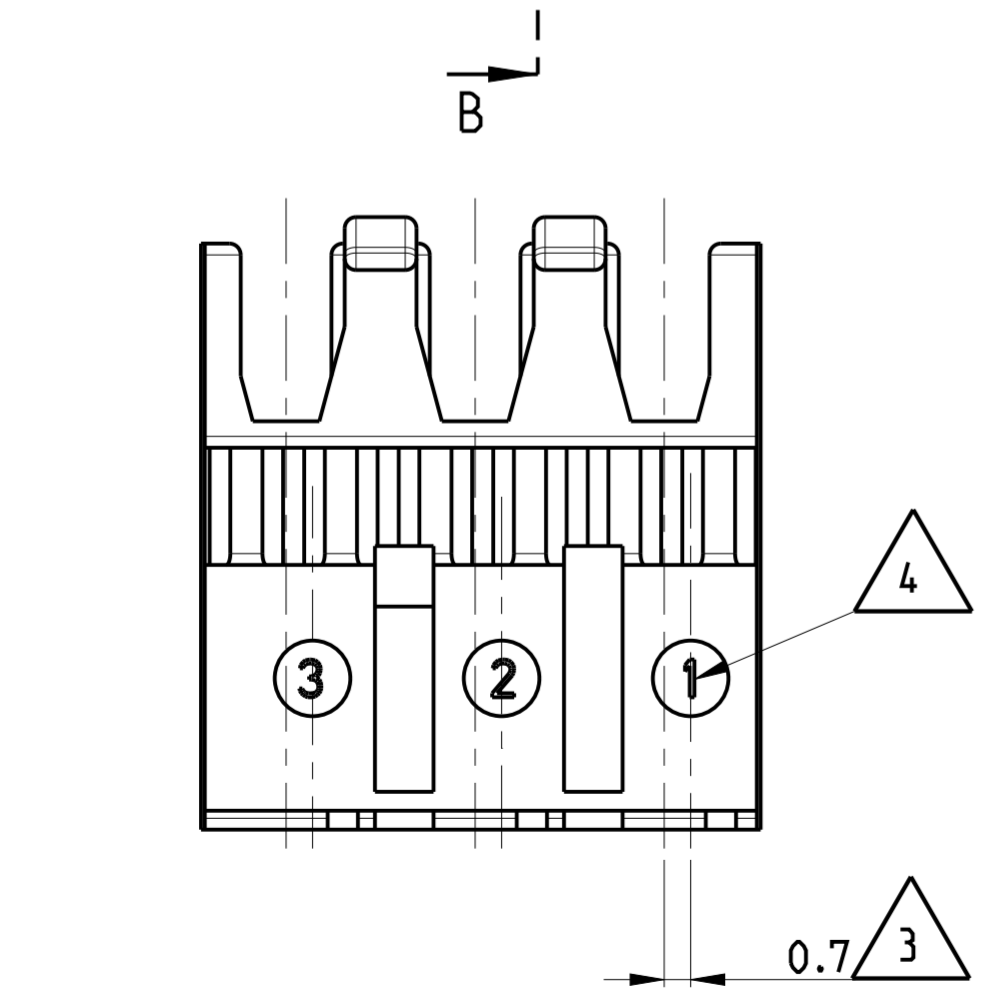
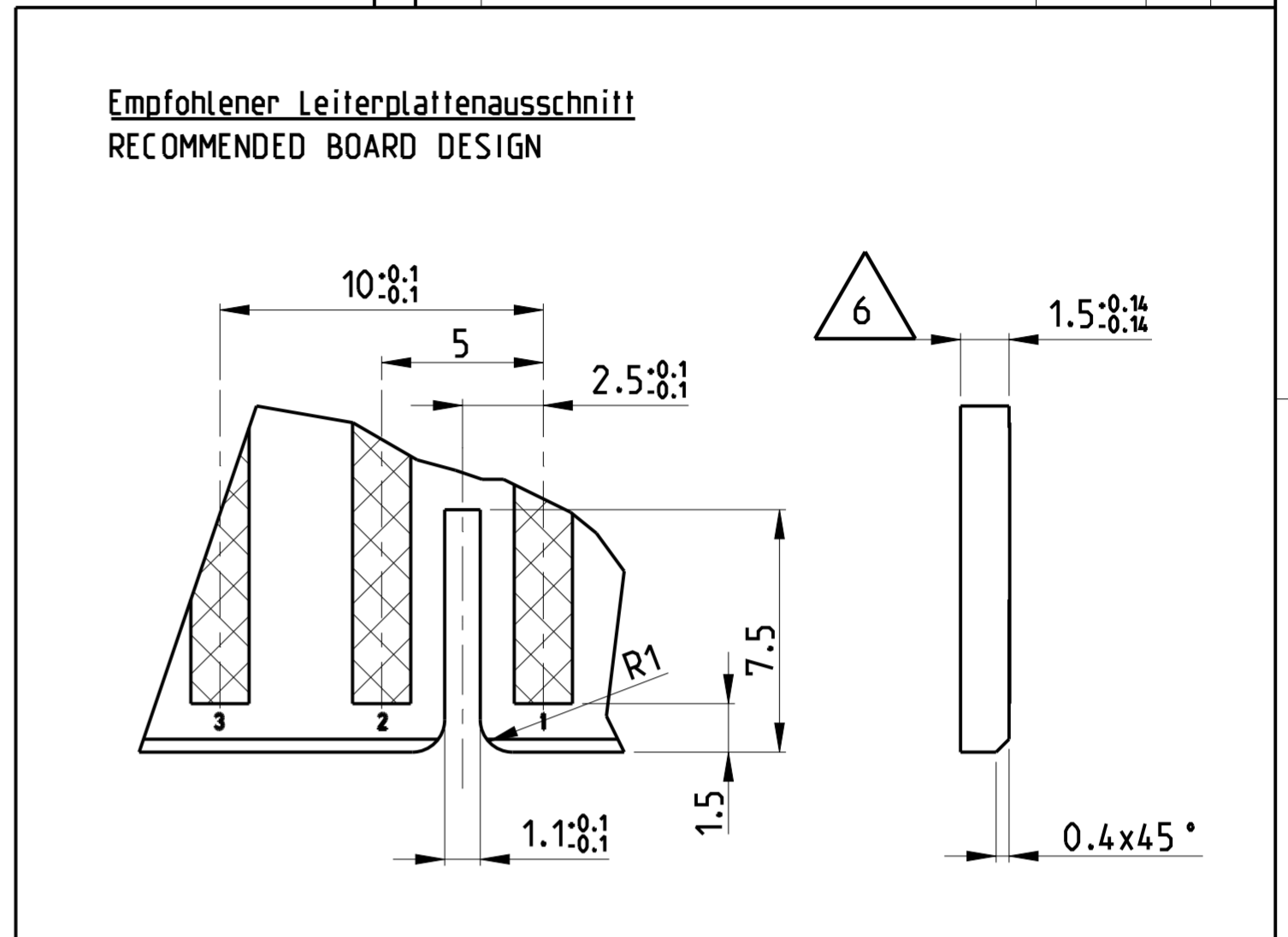
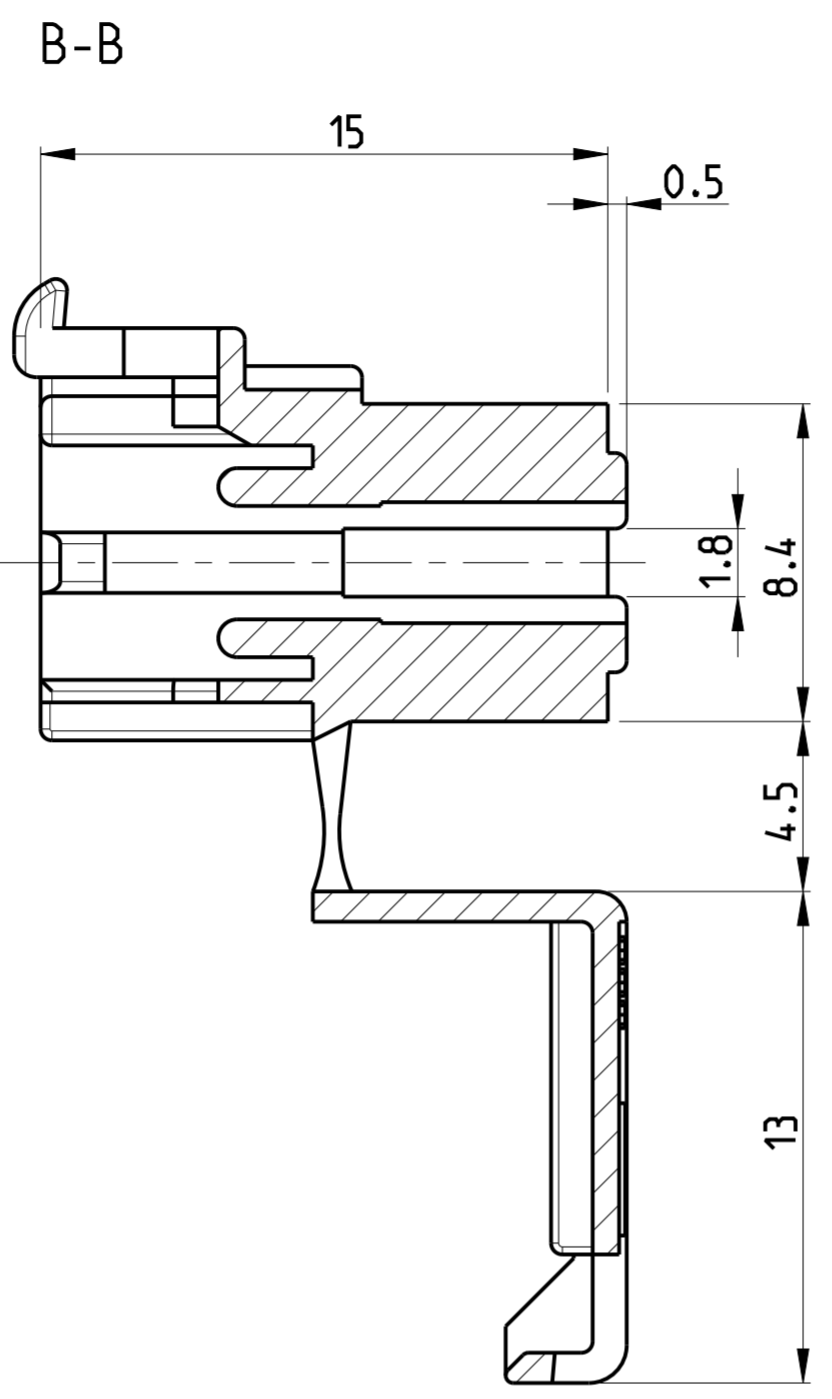
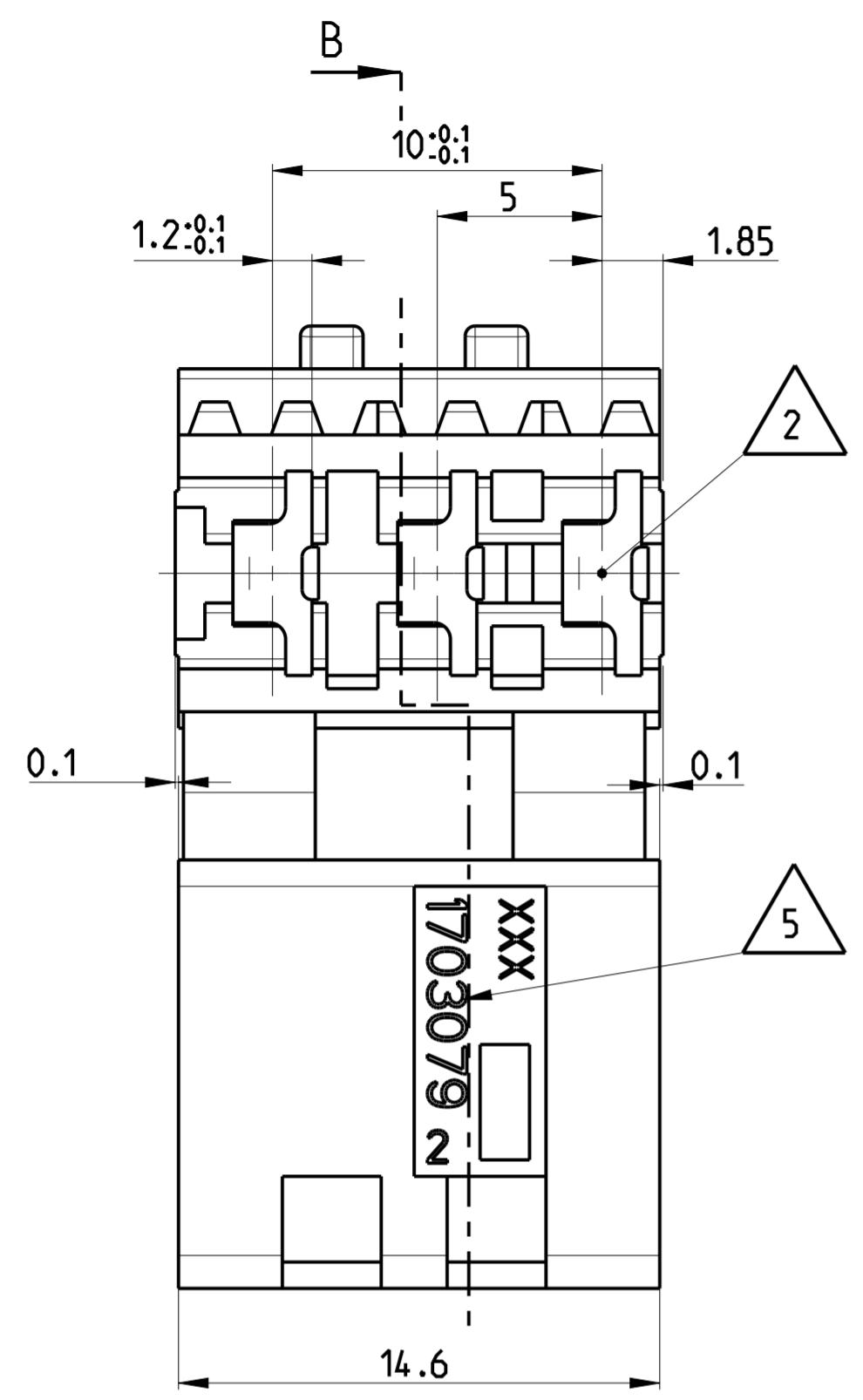

Bemerkungen  
NOTES

- 1 Massgebend ist der deutsche Text  
ONLY THE GERMAN-LANGUAGE VERSION SHALL BE BINDING
- 2 Lage des Kontaktpunktes auf der Leiterplatte; Abweichung ±0.4  
POSITION OF CONTACT POINT ON BOARD; DEVIATION ±0.4
- 3 Kontaktierung zur Drahtmitte um 0.7mm versetzt  
CONTACTING 0.7mm DISPLACED TO WIRE CENTRELINE
- 4 Kontaktkammer-Nr.  
CONTACT CAVITY #
- 5 Firmenlogo und Leergehäuse-Nr.  
ARTWORK LOGO AND HOUSING # (NON LOADED)
- 6 Ausführung nach DIN 60249-2-4  
BOARD DESIGN ACCORDING TO DIN 60249-2-4
- 7 Crimp Kontakt-Nr.:  
Material: CuSn4 926770-1, 926917-1  
CRIMP CONTACT #:  
MATERIAL: CuSn4

1-1703079-1	MT-EDGE HOUSING	NATURE
PART NO.	DESCRIPTION	COLOR

THIS DRAWING IS A CONTROLLED DOCUMENT. DWH MAHNKE, B. 24SEP2004  
 CHK STREDAK, F. 20DEC2004  
 APVD BLFICHER, M. 21DEC2004

DIMENSIONS: mm		TOLERANCES UNLESS OTHERWISE SPECIFIED:		PRODUCT SPEC		NAME	
0 PLC	±	±0.15mm		108-18003		3 POS. MT-EDGE HOUSING RAST 5mm	
1 PLC	±			114-18002		SIZE	CAGE CODE
2 PLC	±					A2	C-1703079
3 PLC	±					SCALE	SHEET
4 PLC	±					5:1	1 OF 1
ANGLES	±°						REV
FINISH							B1

MATERIAL: PA6.6 / UL94V-2 WEIGHT: 1.491 g CUSTOMER DRAWING

RESTRICTED TO: -