

PRODUCT DATA DRAWING

REVISION HISTORY			
REV	DESCRIPTION	DATE	APPROVED
-	NRN 44458	12/19	BNK

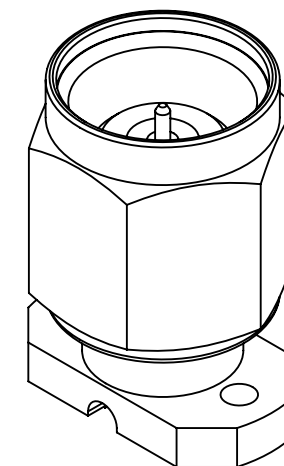
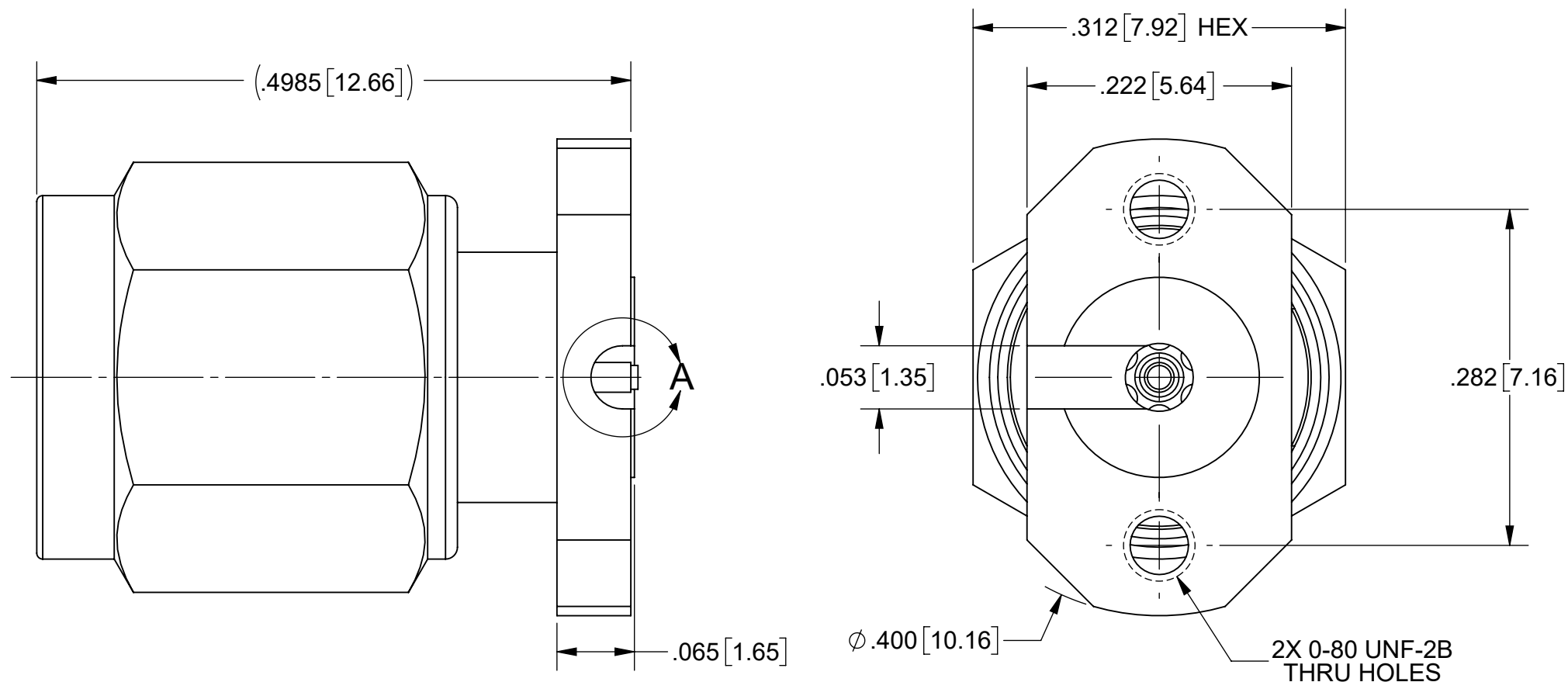

MATERIAL:

BODY, INSERT & COUPLING NUT:

STAINLESS STEEL PER AMS-5640, ALLOY UNS S30300, TYPE 1; OR ASTM A582 TYPE 303, COND. A

LOCK RING & CONTACT:

BERYLLIUM COPPER PER ASTM B196, ALLOY No. UNS C17300, TD04

BEAD:

ULTEM 1000 PER ASTM D5205

GASKET:

SILICONE RUBBER PER A-A-59588, CLASS 2B, GRADE 60/70

FINISH:

BODY, INSERT & COUPLING NUT:

PASSIVATED PER AMS-2700

CONTACT:

GOLD PER ASTM B488, TYPE II, CODE C, CLASS 1.27, OVER NICKEL PER AMS-QQ-N-290, CLASS 1, .00005" MIN.

PERFORMANCE:

IMPEDANCE:
FREQ. RANGE:

50 OHMS
DC TO 50.0 GHZ

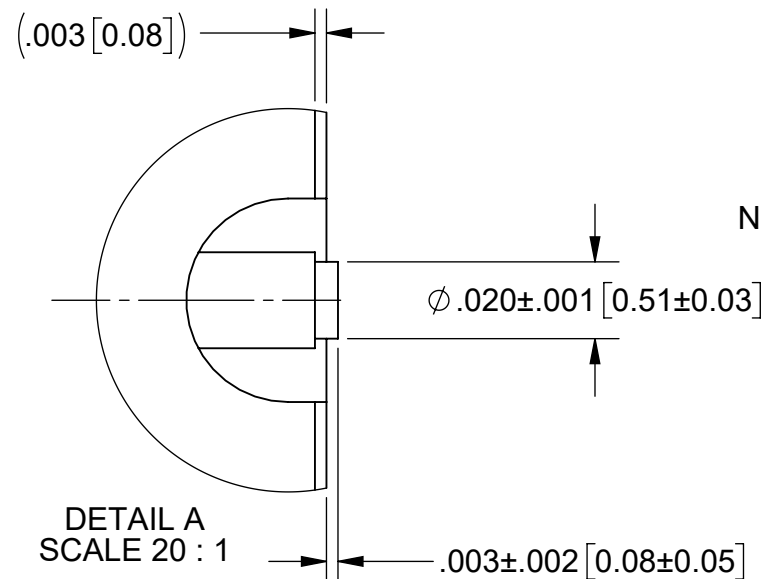

NOTES:

- FOR A FOOTPRINT RECOMMENDATION SPECIFIC TO YOUR PCB, PLEASE CONTACT US AT applications@svmicro.com

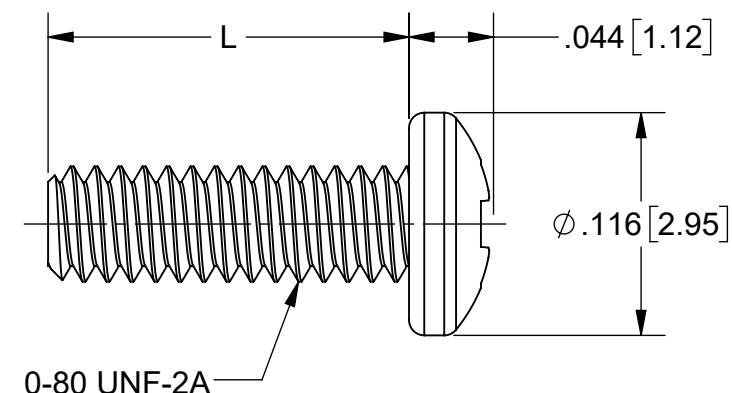

SV P/N	DESCRIPTION	PCB THICKNESS	L
SF1611-60021	NO SCREWS	.005 TO .373	N/A
SF1611-60021-1S	INCL. TWO .188 SCREWS	.032 TO .123	.188
SF1611-60021-2S	INCL. TWO .250 SCREWS	.094 TO .185	.250
SF1611-60021-3S	INCL. TWO .438 SCREWS	.282 TO .373	.438

MATERIAL: SEE NOTES	DIMENSIONS ARE IN INCHES TOLERANCES: FRACTIONAL: ±1/64 ANGULAR: X° ±1'0" X'X' ±15'	UNLESS OTHERWISE SPECIFIED 1) ALL DIMENSIONS ARE IN INCHES (MILLIMETERS) 2) ALL DIMENSIONS ARE AFTER PLATING. 3) BREAK CORNERS & EDGES .005 R. MAX. 4) CHAM. 1ST & LAST THREADS. 5) SURFACE ROUGHNESS 63-MIL-STD-10. 6) DIA: 'S ON COMMON CENTERS TO BE CONCENTRIC WITHIN .005 T.I.R. 7) REMOVE ALL BURRS	 www.svmicrowave.com TITLE: 2.4mm MALE 2 HOLE FLANGE COMPRESSION MOUNT
FINISH: SEE NOTES	DECIMAL: X ±.030 .XX ±.010 .XXX ±.005		
SURFACE AREA: N/A	INTERPRET DIMENSIONS AND TOLERANCES PER ASME Y14.5M - 1994	DRAWN: JDT 12/10/19	SIZE DWG. NO. SF1611-60021-XS SCALE: 8:1 SHEET 1 OF 1
PROPRIETARY THE INFORMATION CONTAINED IN THIS DRAWING IS THE SOLE PROPERTY OF SV MICROWAVE, INC. ANY REPRODUCTION IN PART OR AS A WHOLE WITHOUT THE WRITTEN PERMISSION OF SV MICROWAVE, INC IS PROHIBITED.	THIRD ANGLE PROJECTION	CHECKED: BNK 12/10/19 APPROVED: BNK 12/10/19	