

KNX

Modbus RTU Master and Modbus TCP client

USER MANUAL

Issue date: 05/2019 r1.3 ENGLISH



Important User Information

Disclaimer

The information in this document is for informational purposes only. Please inform HMS Industrial Networks of any inaccuracies or omissions found in this document. HMS Industrial Networks disclaims any responsibility or liability for any errors that may appear in this document.

HMS Industrial Networks reserves the right to modify its products in line with its policy of continuous product development. The information in this document shall therefore not be construed as a commitment on the part of HMS Industrial Networks and is subject to change without notice. HMS Industrial Networks makes no commitment to update or keep current the information in this document.

The data, examples and illustrations found in this document are included for illustrative purposes and are only intended to help improve understanding of the functionality and handling of the product. In view of the wide range of possible applications of the product, and because of the many variables and requirements associated with any particular implementation, HMS Industrial Networks cannot assume responsibility or liability for actual use based on the data, examples or illustrations included in this document nor for any damages incurred during installation of the product. Those responsible for the use of the product must acquire sufficient knowledge in order to ensure that the product is used correctly in their specific application and that the application meets all performance and safety requirements including any applicable laws, regulations, codes and standards. Further, HMS Industrial Networks will under no circumstances assume liability or responsibility for any problems that may arise as a result from the use of undocumented features or functional side effects found outside the documented scope of the product. The effects caused by any direct or indirect use of such aspects of the product are undefined and may include e.g. compatibility issues and stability issues.

Gateway for the integration of Modbus RTU and Modbus TCP installations into KNX TP-1 (EIB) enabled monitoring and control systems.

ORDER CODE	LEGACY ORDER CODE
INKNXMBM1000000	IBKNXMBM1000000
INKNXMBM2500000	IBKNXMBM2500000
INKNXMBM6000000	IBKNXMBM6000000
INKNXMBM1K20000	IBKNXMBM1K20000
INKNXMBM3K00000	IBKNXMBM3K00000

INDEX

1	Description	5
1.1	Introduction	5
1.2	Functionality	6
1.3	Gateway's capacity	6
2	KNX System	7
2.1	Description	7
2.2	Points definition	7
3	Modbus interface of Intesis	8
3.1	Description	8
3.2	Points definition	9
4	Connections	10
4.1	Powering the device	11
4.2	Connection to KNX	11
4.3	Connection to Modbus	11
4.3.1	Modbus TCP	11
4.3.2	Modbus RTU	11
4.4	Connection to the configuration tool	11
5	Set-up process and troubleshooting	12
5.1	Pre-requisites	12
5.2	Intesis MAPS. Configuration & monitoring tool for Intesis KNX series	12
5.2.1	Introduction	12
5.2.2	Connection	12
5.2.3	Configuration tab	13
5.2.4	Signals	13
5.2.5	Sending the configuration to Intesis	14
5.2.6	Diagnostic	14
5.3	Set-up procedure	16
6	Electrical & Mechanical Features	17
7	Dimensions	18

1 Description

1.1 Introduction

This document describes the integration of Modbus RTU and Modbus TCP installations into KNX systems using the Intesis *KNX– Modbus Client* gateway.

The aim of this integration is to make accessible Modbus system signals and resources from a KNX control system or device, as if it was a part of the own KNX TP-1 (EIB) system and vice-versa.

For this, Intesis acts as a Modbus TCP client or Modbus RTU master device in its Modbus interface, reading/writing points of the Modbus slave device(s), and offering this point's values through its KNX interface, acting in the KNX system as one more KNX device of the system. The readings of the Modbus slave device(s) is performed by Intesis by automatic continuous polling.

Configuration is carried out using the configuration software Intesis™ MAPS.

This document assumes that the user is familiar with KNX and Modbus technologies and their technical terms.

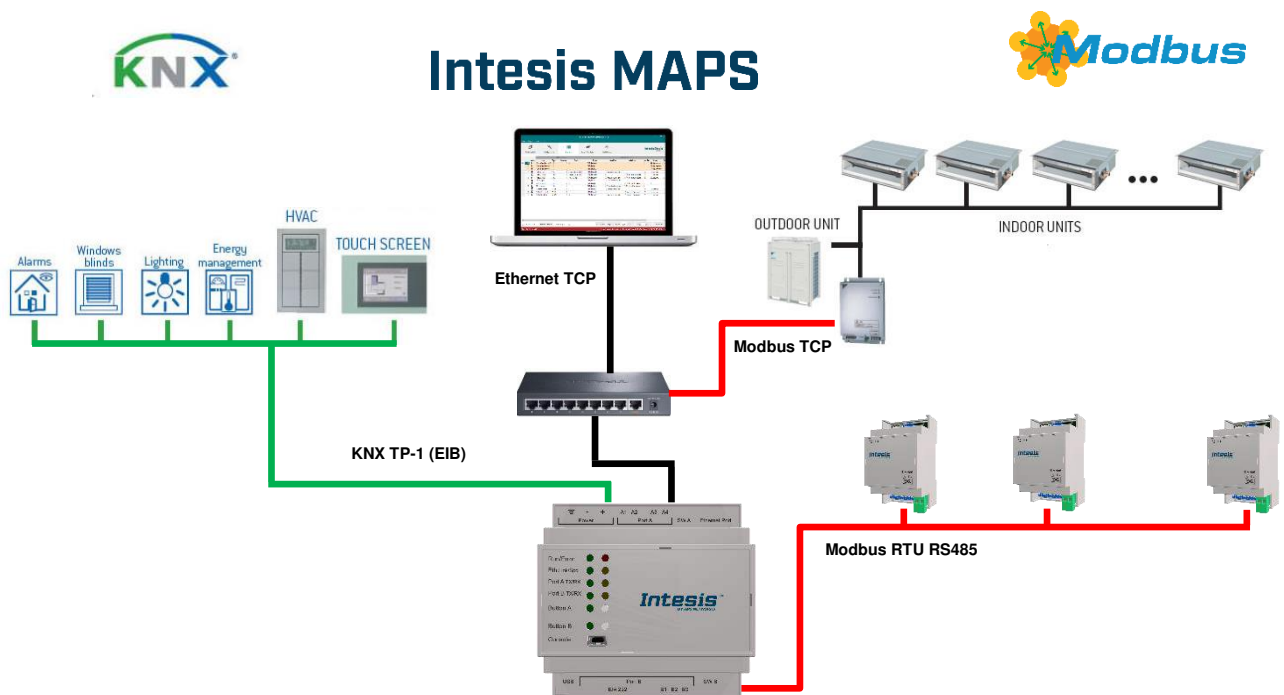

Integration of Modbus RTU Slave or Modbus TCP Servers to KNX TP-1 (EIB)s control and monitoring systems

1.2 Functionality

From the Modbus system point of view, after the start up process, Intesis reads continuously the points configured to be read in the Modbus TCP Server and/or Modbus RTU Slave devices and updates in its memory all the values received from the Modbus system.

Every one of the mentioned Modbus points is associated to a *KNX group address*, with this, all the Modbus system is seen as *one more KNX device* from the KNX system point of view, with the same configuration and operation characteristics.

When a change in any Modbus point occurs, a write telegram is sent to the KNX bus, of the associated *KNX Group*. See details in section 4.

When a telegram is received from the KNX bus, of a *KNX Group address* associated to a Modbus point, a message is sent immediately to the corresponding Modbus device to perform the corresponding action.

In the continuous polling of the Modbus devices, if a non-response of the Modbus device is detected, the corresponding virtual signal inside Intesis will be activated indicating communication error with the Modbus device. These virtual signals indicating communication status in real time with the Modbus devices are also accessible from KNX, like the rest of the points of Intesis.

1.3 Gateway's capacity

Intesis capacity is listed below:

Element	100 version	250 version	600 version	1200 version	3000 version	Notes
Number of Communication Objects	100	250	600	1200	3000	Maximum number of Communication Objects that can be defined.
Number of Main Group Addresses	100	250	600	1200	3000	Maximum number of KNX Main Group Addresses to be used
Number of Associations	200	500	1200	2400	6000	Maximum number of KNX Association
Type of Modbus slave devices	Modbus RTU (EIA485) Modbus TCP					Those supporting Modbus <i>protocol</i> . Communication over TCP/IP and RTU
Number of Modbus Slave devices	Up to 255 Devices per Node (RTU and TCP) Up to 5 TCP connections					Number of Modbus Slave devices supported by the device

2 KNX System

In this section, a common description for all Intesis KNX series gateways is given, from the point of view of KNX system which is called from now on *internal system*. The Modbus system is also called from now on *external system*.

2.1 Description

Intesis KNX connects directly to the KNX TP-1 (EIB) bus and behaves as one more device into the KNX system, with the same configuration and operational characteristics as other KNX devices.

Internally, the circuit part connected to the KNX bus is opto-isolated from the rest of the electronics.

Intesis-KNX receives, manages and sends all the telegrams related to its configuration to the KNX bus.

On receiving telegrams of KNX Groups associated to internal datapoints, the corresponding messages are sent to the external system (Modbus) to maintain both systems synchronised in every moment.

When a change in a signal of the external system is detected, a telegram is sent to the KNX bus (of the associated KNX group) to maintain both systems synchronised in every moment.

The status of the KNX bus is checked continuously and, if a bus drops down is detected, due to a failure in the bus power supply for example, when the KNX bus is restored again, Intesis will retransmit the status of all the KNX groups marked as *"T" Transmit*. Also, the *Updates* of the groups marked as *"U" Update* will be performed. The behaviour of each individual point into Intesis is determined by the flags configured for the point. See details in section 4.

2.2 Points definition

Every internal datapoint to define has the following KNX properties:

Property	Description
Description	Descriptive information about the Communication Object or Signal.
Signal	Signal's Description. Only for informative purposes, allows identifying the signal comfortably.
DPT	It is the KNX data type used to code the signal's value. It will depend on the type of signal associated in the external system in every case. In some integrations, it is selectable, in others it is fixed due to the intrinsic characteristics of the signal.
Group	It is the KNX group to which the point is associated. It is also the group to which the read (R), write (W), transmit (T) and update (U) flags are applied. Is the sending group.
Listening addresses	They are the addresses that will actuate on the point, apart of the main Group address.
R	Read. If this flag is activated, read telegrams of this group address will be accepted.
Ri	Read. If this flag is activated, the object will be read on initialization.
W	Write. If this flag is activated, write telegrams of this group address will be accepted.
T	Transmit. If this flag is activated, when the point's value changes, due to a change in the external system, a write telegram of the group address will be sent to the KNX bus.
U	Update. If this flag is activated, on Intesis start-up or after a KNX bus reset detection, objects will be updated from KNX.
Active	If activated, the point will be active in Intesis, if not, the behaviour will be as if the point is not defined. This allows deactivating points without the need of delete them for possible future use.

These properties are common for all Intesis KNX series gateways. Although each integration may have specific properties according to the type of signals of the external system.

3 Modbus interface of Intesis

3.1 Description

Modbus TCP communication is characterised basically by the embedding of the Modbus RTU protocol into TCP/IP frames. This communication over TCP/IP allows faster communication and a longer distance between master and slave devices in comparison with RTU communication over serial line, and can use common TCP/IP infrastructure in buildings as well as communication over WAN or internet. It allows also the co-existence of one or more masters and of course one or more slave devices in a given network, all of them interconnected through a TCP/IP based network.

Intesis acts as master in the Modbus TCP network, Modbus RTU Master or both and the other Modbus devices connected to the network communicating with Intesis must be always slave or server devices.

Up to 5 Modbus TCP slave devices can be defined in Intesis, to communicate with them.

For each point defined that belongs to a defined Modbus TCP slave device, a slave address from 0 to 255 can be also freely configured, this feature allows great flexibility, for example to integrate Modbus RTU slave devices connected in a serial line and with an RTU/TCP converter on top of this serial line, enabling the access to the RTU slaves' points through TCP/IP, in this case the RTU/TCP converter communicating in TCP identifies the destination of the point (slave address in the RTU network) by the contents of the slave address field.

Modbus TCP slave devices are characterised by their IP address, and their predefined *registers address map*, this address map specifies the address, type and characteristics of each internal point (commonly called *register*) of the Modbus slave device, these registers being accessible using Modbus TCP protocol.

Communication parameters of Intesis's Modbus TCP interface (IP address, Net Mask, Default router address, and TCP port) are fully configurable to adapt to any IP network and slave device.

Modbus TCP protocol defines different types of function codes to use to read/write different type of registers that can be found in Modbus devices, and also different data formats to encode values. See below (section 3.2) all the function codes and data formats supported by Intesis's Modbus interface.

Also the data encoding used for 16 bits registers (big-endian or little-endian) can be configured in Intesis's Modbus interface. This is the byte order for data encoding (MSB..LSB or LSB..MSB). This data encoding, although is specified as big-endian in Modbus protocol specification, it varies depending on manufacturer/type of slave.

All this gives great flexibility to integrate a wide range of Modbus slave devices that can be found in the market.

3.2 Points definition

Each point defined in Intesis has the following Modbus features associated to it:

Feature	Description
Modbus Device	<p>Modbus TCP device to which belongs the point, from a list of Modbus TCP slave devices that can be defined in Intesis (up to 5).</p> <p>For every Modbus TCP slave device defined, a virtual signal is created automatically in Intesis to inform about the communication with the device, this signal is available also from the KNX interface like the rest of the points.</p>
Function code Read Func Write Func	<p>One of the following Modbus function codes can be used:</p> <ul style="list-style-type: none"> • 1- Read Coils. • 2- Read Discrete Inputs. • 3- Read Holding Registers. • 4- Read Input Registers. • 5- Write Single Coil. • 6- Write Single Register. • 15- Write Multiple Coils. • 16- Write Multiple Registers.
#Bits	Number of bits to be used by this signal.
Data Coding Format	<p>One of the following Modbus data coding formats can be used:</p> <ul style="list-style-type: none"> • 16/32/48/64 bits unsigned. • 16/32/48/64 bits signed (one's complement – C1). • 16/32/48/64 bits signed (two's complement – C2). • 16/32/48/64 bits Float. • 16/32/48/64 bits Bitfields. • Error comm
Byte Order	<ul style="list-style-type: none"> • Big Endian • Little Endian • Word Inverted Big Endian • Word Inverted Little Endian
Register Address	The Modbus register address inside the slave device for the point.
Bit inside the register	<p>Bit inside the Modbus register (optional). The gateway allows bit decoding from generic 16 bits input/holding Modbus registers.</p> <p><i>Bit coding into 16 bit input/holding Modbus registers is used for some devices to encode digital values into this type of registers, being these registers normally accessible using Modbus function codes 3 and 4 (read holding/input registers).</i></p>

4 Connections

Find below information regarding the Intesis connections available.

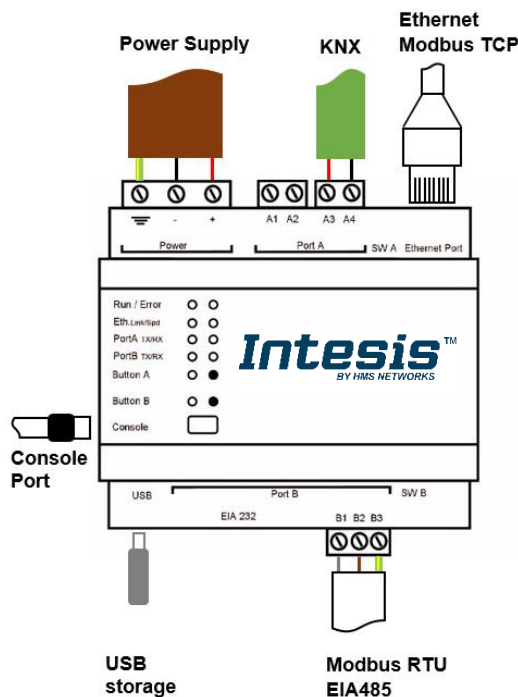

Power Supply

Must use NEC Class 2 or Limited Power Source (LPS) and SELV rated power supply.

If using DC power supply:

Respect polarity applied of terminals (+) and (-). Be sure the voltage applied is within the range admitted (check table below). The power supply can be connected to earth but only through the negative terminal, never through the positive terminal.

If using AC power supply:

Make sure the voltage applied is of the value admitted (24 Vac). Do not connect any of the terminals of the AC power supply to earth, and make sure the same power supply is not supplying any other device.

Ethernet / Modbus TCP

Connect the cable coming from the IP network to the connector ETH of the gateway. Use an Ethernet CAT5 cable. If communicating through the LAN of the building, contact the network administrator and make sure traffic on the port used is allowed through all the LAN path (check the gateway user manual for more information). With factory settings, after powering up the gateway, DHCP will be enabled for 30 seconds. After that time, if no IP is provided by a DHCP server, the default IP 192.168.100.246 will be set.

PortA / KNX

Connect the KNX TP1 bus to connectors A3 (+) and A4 (-) of gateway's PortA. Respect the polarity

PortB / Modbus RTU

Connect the EIA485 bus to connectors B1 (+), B2 (-) and B3 (SNGD) of gateway's PortB. Respect the polarity.

Note for PortB; Remember the characteristics of the standard EIA485 bus: maximum distance of 1200 meters, maximum 32 devices connected to the bus, and in each end of the bus it must be a termination resistor of 120 Ω. The gateway has an internal bus biasing circuit that incorporates the termination resistor. If you install the gateway in one of the ends of the bus, then do not install an additional termination resistor in that end.

Console Port

Connect a mini-type B USB cable from your computer to the gateway to allow communication between the Configuration Software and the gateway. Remember that Ethernet connection is also allowed. Check the user manual for more information.

USB

Connect a USB storage device (not a HDD) if required. Check the user manual for more information.

Ensure proper space for all connectors when mounted (see section 7).

4.1 Powering the device

A power supply working with any of the voltage range allowed is needed (check section 6). Once connected the RUN led (Figure above) will turn on.

WARNING! In order to avoid earth loops that can damage the gateway and/or any other equipment connected to it, we strongly recommend:

- The use of DC power supplies, floating or with the negative terminal connected to earth. **Never use a DC power supply with the positive terminal connected to earth.**
- The use of AC power supplies only if they are floating and not powering any other device.

4.2 Connection to KNX

Connect the communication cable coming from the KNX network hub or switch to the ETH port (Figure above) of Intesis.

In case there is no response from the KNX installation or KNX devices to the frames sent by Intesis, check that they are operative and reachable from the network connection used by Intesis.

Check as well if there is a line coupler that it is not filtering the telegrams from/to the Intesis.

4.3 Connection to Modbus

4.3.1 Modbus TCP

Connect the communication cable coming from the KNX TP-1 network to the KNX port of Intesis. The cable to be used shall be a straight Ethernet UTP/FTP CAT5 cable.

4.3.2 Modbus RTU

Connect the communication cable coming from the Modbus network to the port marked as Modbus of Intesis. Connect the EIA485 bus to connectors B1 (+), B2 (-) and B3 (SNGD) of gateway's PortB. Respect the polarity.

Remember the characteristics of the standard EIA485 bus: maximum distance of 1200 meters, maximum 32 devices connected to the bus, and in each end of the bus it must be a termination resistor of 120 Ω . The gateway has an internal bus biasing circuit that incorporates the termination resistor. If you install the gateway in one of the ends of the bus, then do not install an additional termination resistor in that end.

4.4 Connection to the configuration tool

This action allows the user to have access to configuration and monitoring of the device (more information can be found in the configuration tool User Manual). Two methods to connect to the PC can be used:

- **Ethernet:** Using the Ethernet port of Intesis.
- **USB:** Using the console port of Intesis, connect a USB cable from the console port to the PC.

5 Set-up process and troubleshooting

5.1 Pre-requisites

It is necessary to have a KNX installation, device or interface operative and well connected to the corresponding KNX port of Intesis and a Modbus RTU slave or Modbus TCP client connected to their corresponding ports as well.

Connectors, connection cables, PC to use the configuration tool and other auxiliary material, if needed, are not supplied by HMS Industrial Networks S.L.U for this standard integration.

Items supplied by HMS Networks for this integration are:

- Intesis gateway.
- Link to download the configuration tool.
- Product documentation.

5.2 Intesis MAPS. Configuration & monitoring tool for Intesis KNX series

5.2.1 Introduction

Intesis MAPS is a Windows® compatible software developed specifically to monitor and configure Intesis KNX series.

The installation procedure and main functions are explained in the *Intesis MAPS User Manual*. This document can be downloaded from the link indicated in the installation sheet supplied with the Intesis device or in the product website at www.intesis.com

In this section, only the specific case of Modbus to KNX systems will be covered.

Please check the Intesis MAPS user manual for specific information about the different parameters and how to configure them.

5.2.2 Connection

To configure the Intesis connection parameters press on the **Connection** button in the *menu bar*.

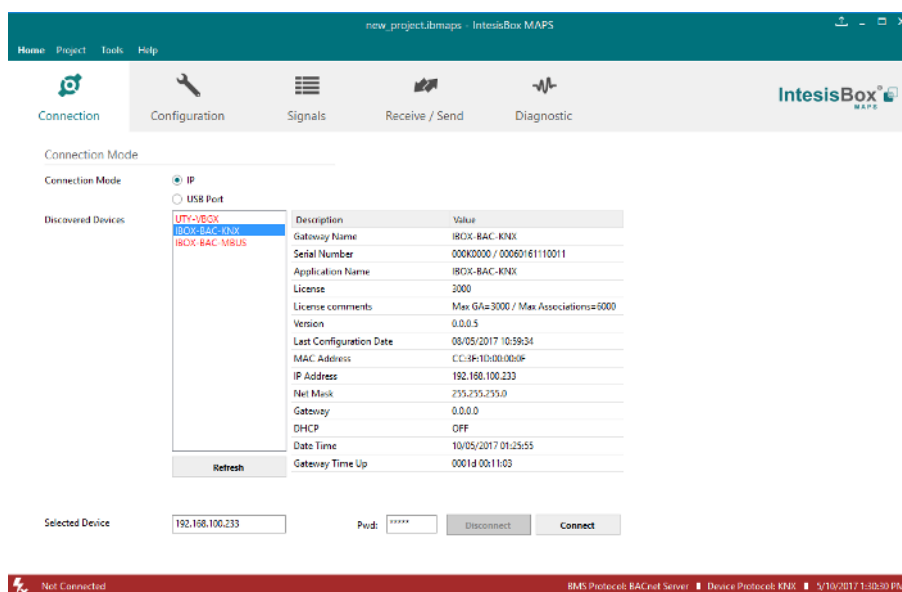

Figure 5.1 MAPS connection

5.2.3 Configuration tab

Select the **Configuration** tab to configure the connection parameters. Three subsets of information are shown in this window: General (Gateway general parameters), KNX (KNX interface configuration) and Modbus Client (Modbus interface parameters).

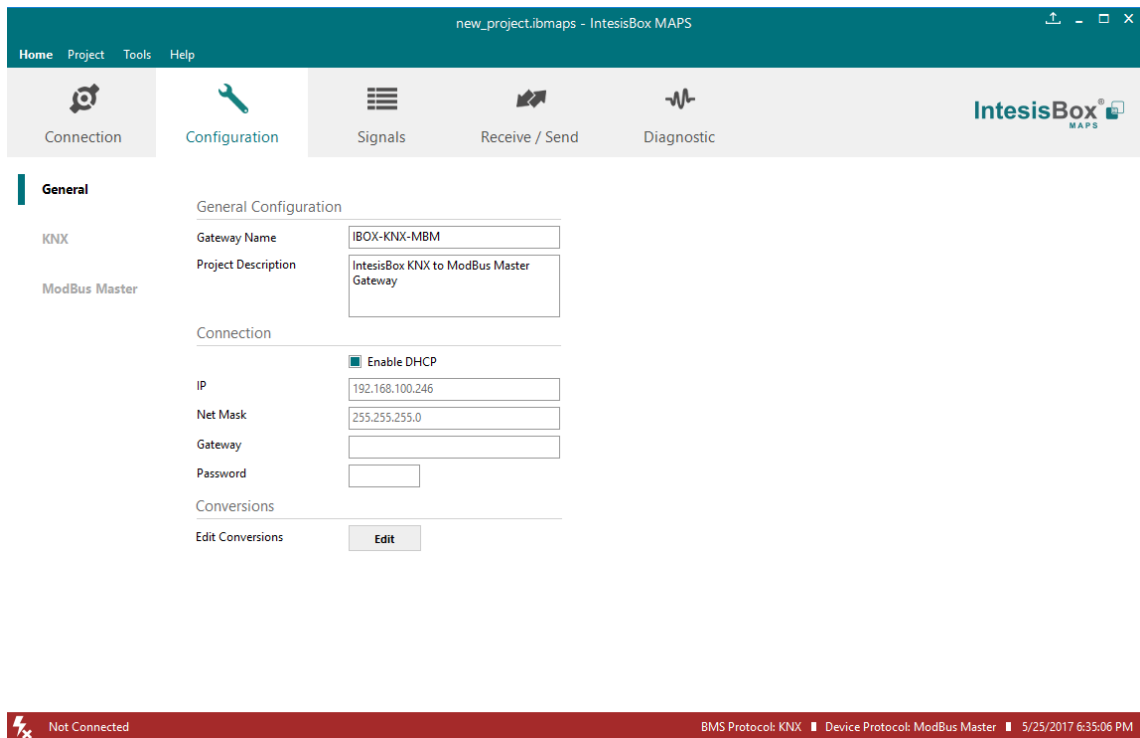

Figure 5.2 Intesis MAPS configuration tab

5.2.4 Signals

All available objects, Object Instances, its corresponding Modbus register and other main parameters are listed in the signals tab. More information on each parameter and how to configure it can be found in the Intesis MAPS user manual.

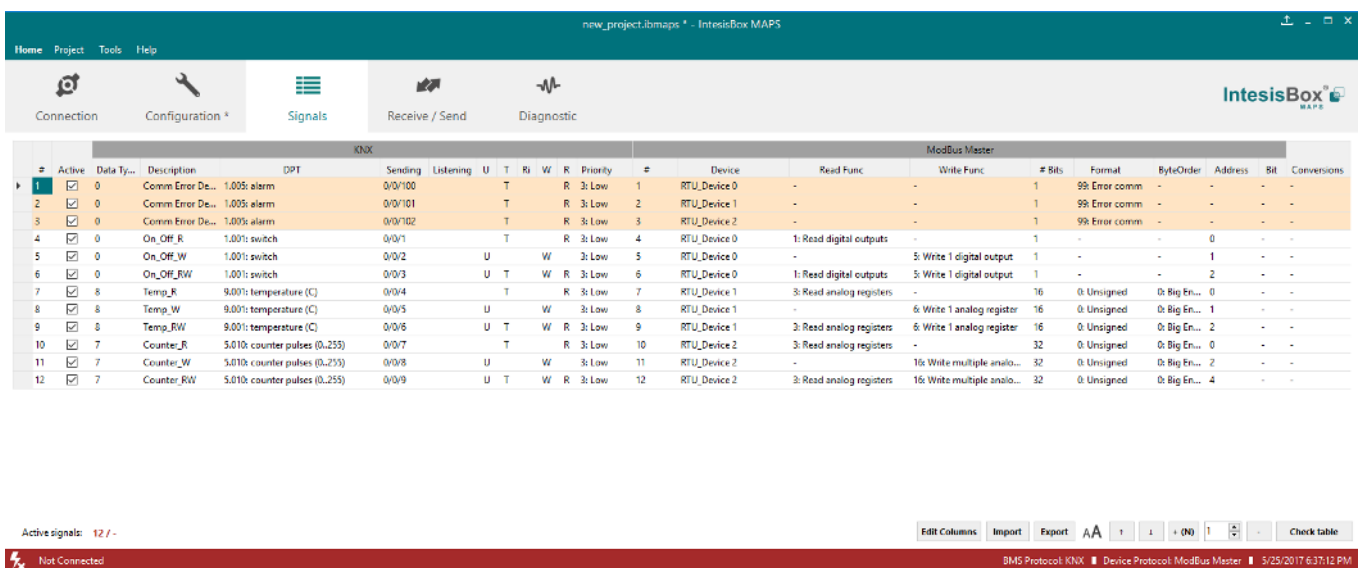

Figure 5.3 Intesis MAPS Signals tab

5.2.5 Sending the configuration to Intesis

When the configuration is finished, follow the next steps.

- 1.- Click on **Save** button to save the project to the project folder on your hard disk (more information in Intesis MAPS User Manual).
- 2.- You will be prompted to generate the configuration file to be sent to the gateway.
 - a.- If **Yes** is selected, the file containing the configuration for the gateway will be generated and saved also into the project folder.
 - b.- If **NO** is selected, remember that the binary file with the project needs to be generated before the Intesis starts to work as expected.
- 3.- Press the **Send File** button to send the binary file to the Intesis device. The process of file transmission can be monitored in the Intesis Communication Console window. Intesis will reboot automatically once the new configuration is loaded.

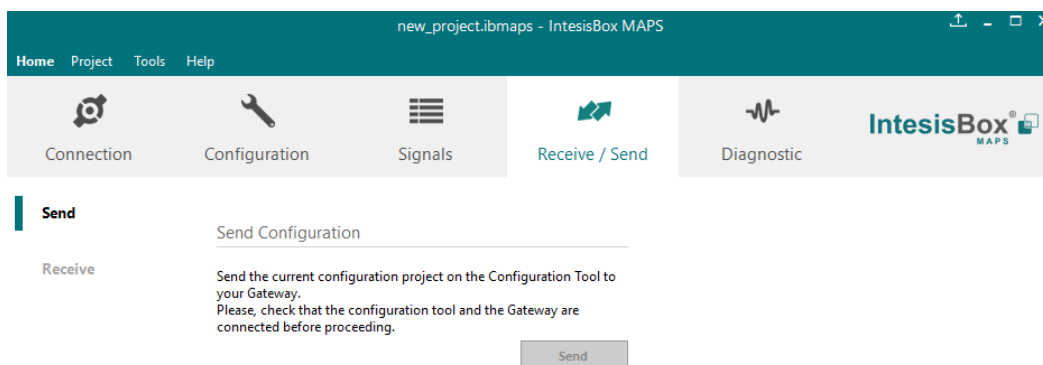

Figure 5.4 Intesis MAPS Receive/Send tab

After any configuration change, do not forget to send the configuration file to the Intesis using button Send File.

5.2.6 Diagnostic

To help integrators in the commissioning tasks and troubleshooting, the Configuration Tool offers some specific tools and viewers.

In order to start using the diagnostic tools, connection with the Gateway is required.

The Diagnostic section is composed by two main parts: Tools and Viewers.

- **Tools**

Use the tools section to check the current hardware status of the box, log communications into compressed files to be sent to the support, change the Diagnostic panels' view or send commands to the gateway.
- **Viewers**

In order to check the current status, viewer for the Internal and External protocols are available. It is also available a generic Console viewer for general information about communications and the gateway status and finally a Signals Viewer to simulate the BMS behavior or to check the current values in the system.

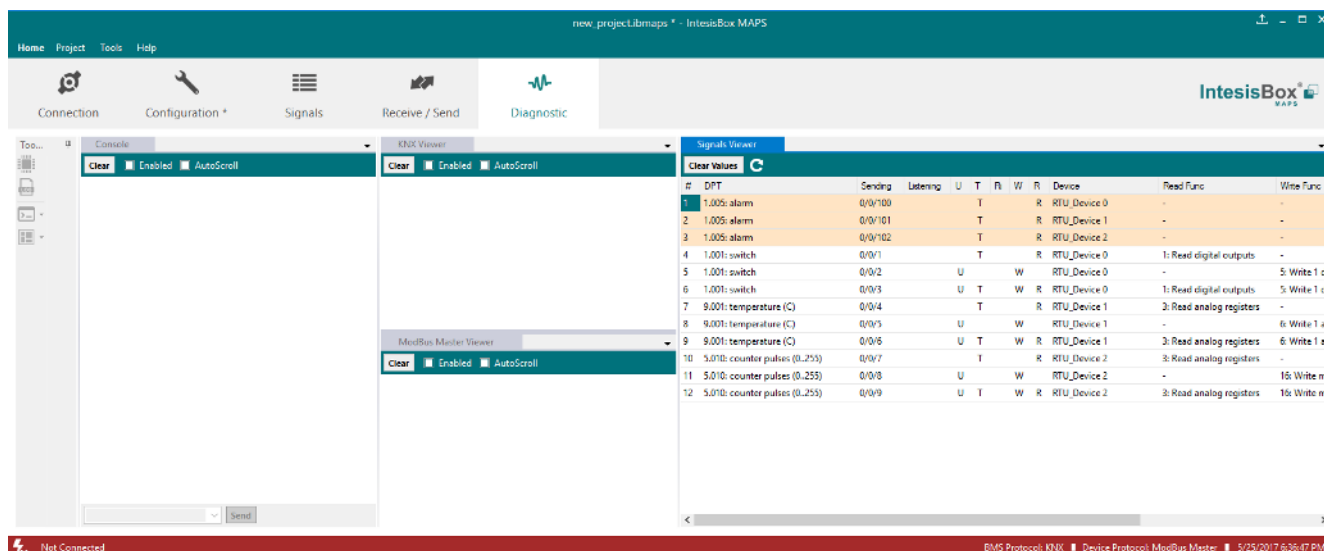

Figure 5.5 Diagnostic

More information about the Diagnostic section can be found in the Configuration Tool manual.

5.3 Set-up procedure

1. Install Intesis MAPS on your laptop, use the setup program supplied for this and follow the instructions given by the Installation wizard.
2. Install Intesis in the desired installation site. Installation can be on DIN rail or on a stable not vibrating surface (DIN rail mounted inside a metallic industrial cabinet connected to ground is recommended).
3. Connect the KNX communication cable coming from the KNX network to the port marked as Port A on Intesis (More details in section 4).
4. If using, Modbus RTU, connect the communication cable coming from the EIA485 port of the Modbus RTU installation to the port marked as Port B of Intesis (More details in section 4).

If using, Modbus TCP, connect the communication cable coming from the Ethernet port of the Modbus TCP installation to the port marked as Port B of Intesis (More details in section 4).

5. Power up Intesis. The supply voltage can be 9 to 30 Vdc or just 24 Vac. Take care of the polarity of the supply voltage applied.

WARNING! In order to avoid earth loops that can damage Intesis and/or any other equipment connected to it, we strongly recommend:

- The use of DC power supplies, floating or with the negative terminal connected to earth. **Never use a DC power supply with the positive terminal connected to earth.**
 - The use of AC power supplies only if they are floating and not powering any other device.
6. If you want to connect using IP, connect the Ethernet cable from the laptop PC to the port marked as USB of Intesis (More details in section 4).

If you want to connect using IP, connect the Ethernet cable from the laptop PC to the port marked as USB of Intesis (More details in section 4).

7. Open Intesis MAPS, create a new project selecting a copy of the one named **INKNXMBM---0000**.
8. Modify the configuration as desired, save it and download the configuration file to Intesis as explained in the Intesis MAPS user manual.
9. Visit the Diagnostic section and check that there is communication activity, some TX frames and some other RX frames. This means that the communication with the KNX installation and Modbus Slave devices is OK. In case there is no communication activity between Intesis and the KNX and/or Modbus devices, check that those are operative: check the baud rate, the communication cable used to connect all devices and any other communication parameter.

6 Electrical & Mechanical Features



Enclosure	Plastic, type PC (UL 94 V-0) Net dimensions (d×w×h): 90x88x56 mm Recommended space for installation (d×w×h): 130x100x100mm Color: Light Grey, RAL 7035
Mounting	Wall. DIN rail EN60715 TH35.
Terminal Wiring (for power supply and low-voltage signals)	Per terminal: solid wires or stranded wires (twisted or with ferrule) 1 core: 0.5mm ² ... 2.5mm ² 2 cores: 0.5mm ² ... 1.5mm ² 3 cores: not permitted
Power	1 x Plug-in screw terminal block (3 poles) 9 to 36VDC +/-10%, Max.: 140mA. 24VAC +/-10% 50-60Hz, Max.: 127mA Recommended: 24VDC
Ethernet	1 x Ethernet 10/100 Mbps RJ45 2 x Ethernet LED: port link and activity
Port A	1 x KNX TP-1 Plug-in screw terminal block orange (2 poles) 2500VDC isolation from other ports KNX power consumption: 5mA Voltage rating: 29VDC 1 x Plug-in screw terminal block green (2 poles) Reserved for future use
Switch A (SWA)	1 x DIP-Switch for PORT A configuration: Reserved for future use
PORT B	1 x Serial EIA232 (SUB-D9 male connector) Reserved for future use 1 x Serial EIA485 Plug-in screw terminal block (3 poles) A, B, SGND (Reference ground or shield) 1500VDC isolation from other ports <i>(except PORT B: EIA232)</i>
Switch B (SWB)	1 x DIP-Switch for serial EIA485 configuration: Position 1: ON: 120 Ω termination active Off: 120 Ω termination inactive Position 2-3: ON: Polarization active Off: Polarization inactive

Battery	Size: Coin 20mm x 3.2mm Capacity: 3V / 225mAh Type: Manganese Dioxide Lithium
Console Port	Mini Type-B USB 2.0 compliant 1500VDC isolation
USB port	Type-A USB 2.0 compliant Only for USB flash storage device <i>(USB pen drive)</i> Power consumption limited to 150mA <i>(HDD connection not allowed)</i>
Push Button	Button A: Check the user manual Button B: Check the user manual
Operation Temperature	0°C to +60°C
Operational Humidity	5 to 95%, no condensation
Protection	IP20 (IEC60529)
LED Indicators	10 x Onboard LED indicators 2 x Run (Power)/Error 2 x Ethernet Link/Speed 2 x Port A TX/RX 2 x Port B TX/RX 1 x Button A indicator 1 x Button B indicator

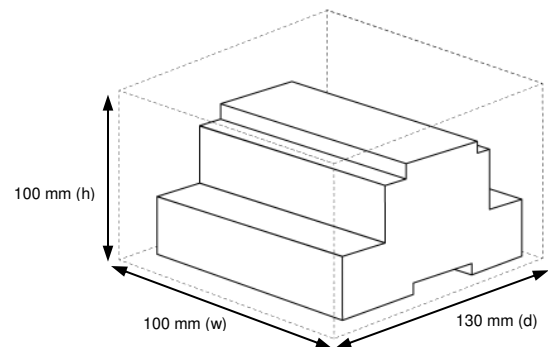

7 Dimensions

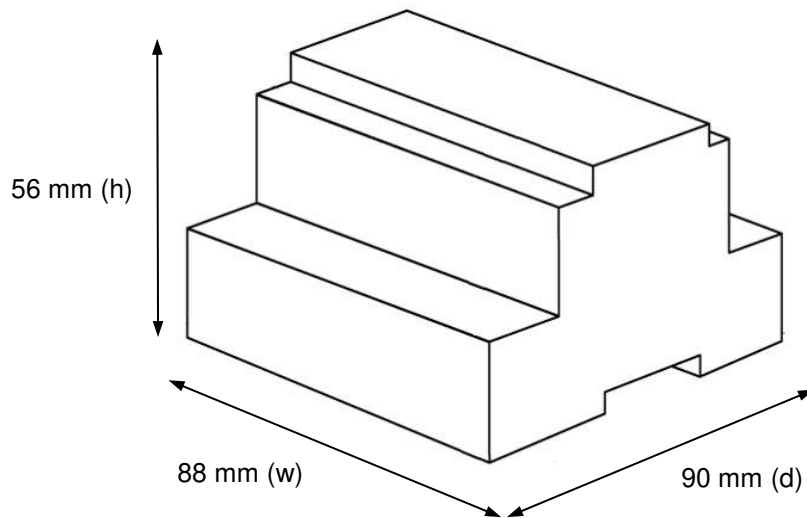

Recommended available space for its installation into a cabinet (wall or DIN rail mounting), with space enough for external connections

