

PART NUMBER	REV	FIRST USED	POWER UNIT	FEED TYPE
1385719-1	H	122500-1	LEADMAKER	AIR FEED
1385719-2	H	565435-5	BENCH MODEL K	AIR FEED
1385719-3	H	354500-1	BENCH MODEL G	AIR FEED
1385719-4	H	KOMAX	KOMAX	AIR FEED

TERMINAL NAME: .250 SERIES RECEPTACLE, ULTRA-POD™

REF SETTING	CRIMP HEIGHT	WIRE SIZE			
B5	.076 ±.002 [1.93 ±0.05mm]	#14			
C5	.071 ±.002 [1.80 ±0.05mm]	2- #18			
D3	.067 ±.002 [1.70 ±0.05mm]	#16 or (1)#18 + (1)#20			
E3	.061 ±.002 [1.55 ±0.05mm]	#18 or (2)#20			
CRIMP	SIZE	TYPE	RANGE		
WIRE	.110 [2.79mm]	F	#14-#18 or (2)#18 or (1)18 + (1)#20 or #18 or (2)#20		
INSUL	.240 [6.09mm]	F	.110-.170 or 2-.105 MAX		
WIRE STRIP LENGTH	TERM APPL SPEC	FEED	APPL INSTRUCTION	SET UP GAGE	LAYOUT
.210-.240	114-02124	.760	408-8095 & 408-8098	-	-

- 1 RECOMMENDED SPARE PARTS
- 2 ITEMS NOT SHOWN
- 3 TOL ±.25

*** WARNING:**
 ON INSTALLATION, SET WIRE DISC TO LARGEST WIRE SIZE SETTING. USE OF SETTINGS BELOW MIN REQUIRED CRIMP HEIGHT SETTING WILL CAUSE DAMAGE TO CRIMP TOOLING.

- 4. SPRING LOADED TONKER REQUIRED WHEN RUNNING APPLICATOR ON LEADMAKER.
- 5. WIRE PLACEMENT AND STRAIGHTNESS IS EXTREMELY CRITICAL FOR CONSISTANT TERMINAL BARREL. IF THE WIRE COLLECTION OF THE WIRE INTO THE PRESENTATION IS NOT CORRECT OR CONSISTANT, FAULTY TERMINATIONS WILL RESULT.

QTY REQD PER ASSY	PART NO	DESCRIPTION	ITEM NO
-	REF	-	679532-1
2	2	2	21017-2
1	1	1	461264-5
-	-	1	28582-1
-	-	2	22311-2
-	-	1	28580-1
-	-	1	23791-2
-	-	1	22307-1
-	-	1	26108-1
1	1	1	19832-1
2	2	2	4-21000-3
2	2	2	21024-5
1	1	1	21024-8
80	65	65	27319-4
2	2	1	23238-1
-	-	1	455755-8
1	1	1	21009-7
1	1	1	459610-3
-4	-3	-2	-1

QTY REQD PER ASSY	PART NO	DESCRIPTION	ITEM NO
1	1	1	690125-1
1	1	1	21009-2
1	1	1	690191-1
1	1	1	461690-1
-	-	1	692655-1
2	2	2	2-21002-9
2	2	2	3-21000-7
1	1	1	852224-1
1	1	1	461062-6
1	1	1	3-21001-4
1	1	1	852289-1
2	2	2	1-23030-2
1	-	-	1-455888-0
1	1	1	852253-1
1	-	-	1490524-2
1	-	-	1490525-1
1	-	-	1424350-1
-	1	1	1338045-1
3	-	-	2-23147-2
1	1	1	21024-4
1	1	1	2-22603-1
4	4	4	2-21002-6
-	1	1	2-21000-7
-	2	2	1-21003-3
-	4	4	7-22280-3
1	1	1	1673936-2
-	1	1	1-455888-6
-	1	1	455888-4
1	1	1	1424388-2
1	1	1	6-1490019-6
1	1	1	6-1424909-6
1	1	1	238011-2
1	1	1	1-455888-5
1	1	1	2-24921-5
1	-	-	455888-5
1	1	1	1-22183-7
1	1	1	2-22286-2
1	1	1	1-21919-1
1	1	1	852281-2
1	1	1	354385-4
1	1	1	852287-1
1	1	1	852286-1
2	2	2	852521-1
1	1	1	852284-1
1	1	1	1-21030-7
3	2	2	980282-3
-	1	-	980285-2
2	2	2	22733-3

QTY REQD PER ASSY	PART NO	DESCRIPTION	ITEM NO
1	1	1	852245-2
1	1	1	852246-1
1	1	1	856287-1
1	1	-	22374-7
2	1	-	22304-1
1	-	-	22306-1
1	-	-	23054-1
18	-	-	27319-8
1	-	-	1424324-1
-	1	1	1338042-7
-	1	1	1338042-5
2	2	2	6-21002-1
-	1	1	1338043-1
-	1	1	1338044-1
1	1	1	1-1338056-3
-	1	1	1338041-1
-	1	1	1-21000-9
1	1	1	879103-3
1	1	1	469367-9
1	1	1	852250-1
2	2	2	22354-7
1	1	1	852251-2
2	2	2	2-22280-9
2	2	2	21021-3
1	1	1	90594-1
4	4	4	21055-6
1	1	1	90591-1
1	1	1	853981-1
-	-	-	-
1	1	1	1338060-1
1	-	-	455888-1
1	-	-	1633303-1
1	-	-	1-21002-3
1	-	-	1633289-2
1	-	-	3-238009-7
4	4	4	23030-2
2	2	2	22733-9
1	1	1	354993-1
1	1	1	22733-8
2	2	2	2-21002-2
1	1	1	1-23470-7
1	1	1	90777-1
1	1	1	318198-1
12	12	12	2-21002-1
1	1	1	90775-1
1	1	1	1338955-1
3	3	3	2-22733-8
1	1	1	1424368-3
1	1	1	1424387-1
-4	-3	-2	-1

LOC A
DIST 66

DATE	BY	REV	DESCRIPTION
9-2009	MY GB		REVISION RECORD

DIMENSIONS INCHES	TOLERANCES UNLESS OTHERWISE SPECIFIED:
0 PLC ±.005	1 PLC ±.002
2 PLC ±.002	3 PLC ±.001
4 PLC ±.0005	5 PLC ±.0005

DWN	9-27-95	MATERIAL	-	HEAT TREAT	-
CHK	9-28-95				
APVD	9-28-95				
NAME	ULTRA-POD APPLICATOR .250 STRAIGHT				
SCALE	1:1	SIZE	A1	DRAWING NO	1385719
SHEET	1	OF	3	REV	H

CUSTOMER ACCESSIBLE PRODUCTION DRAWING

THIS DRAWING IS A CONTROLLED DOCUMENT.

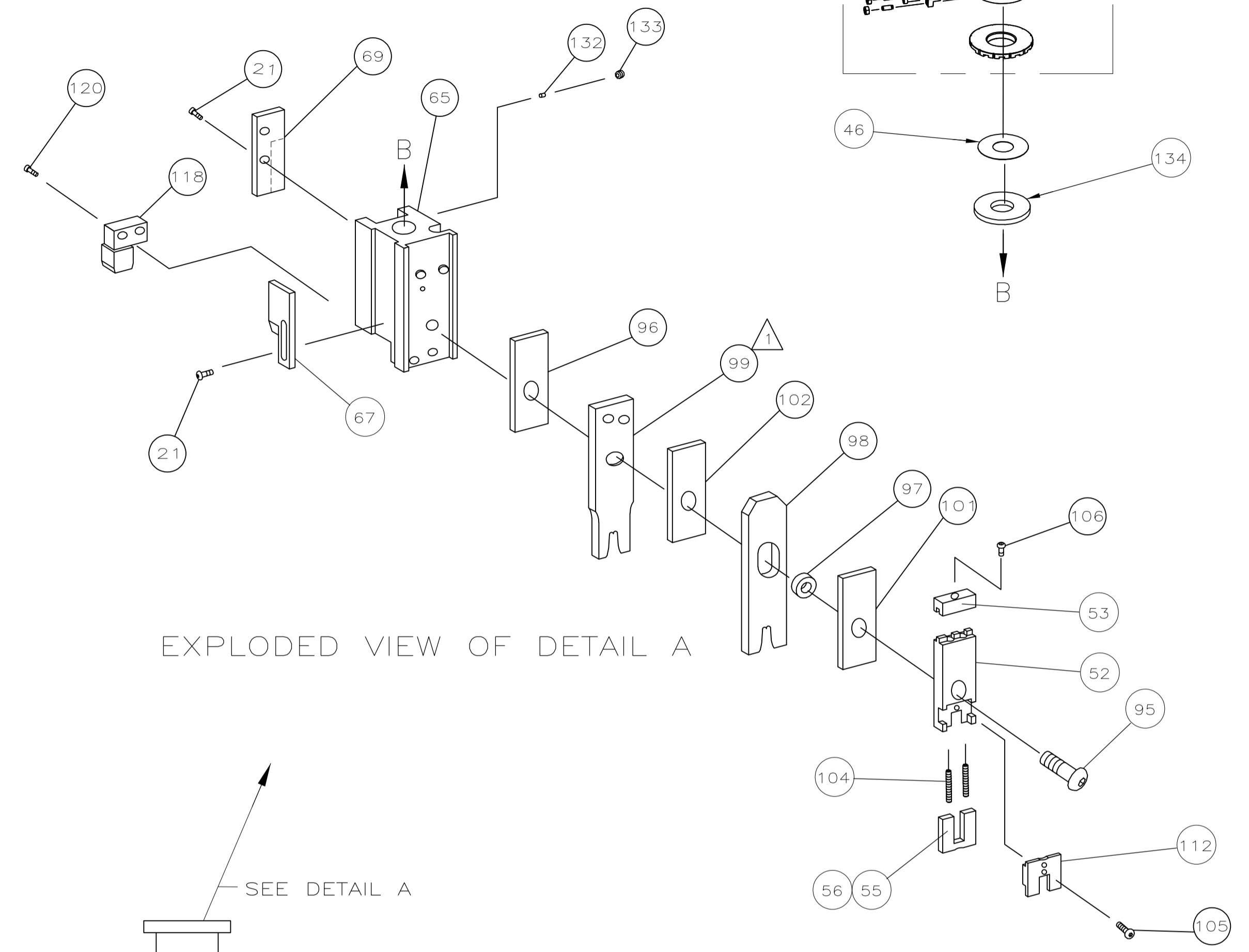
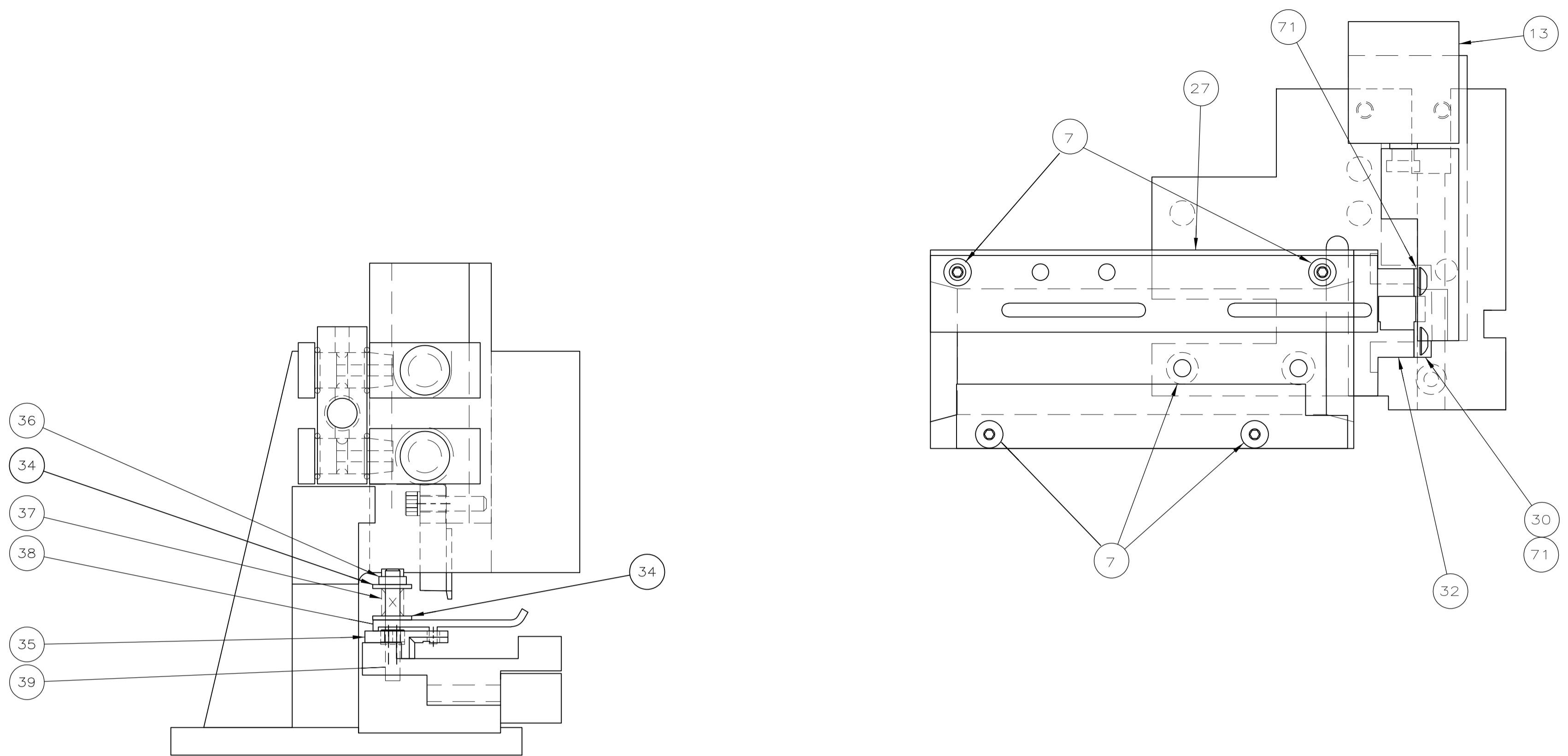

EXPLODED VIEW OF DETAIL A

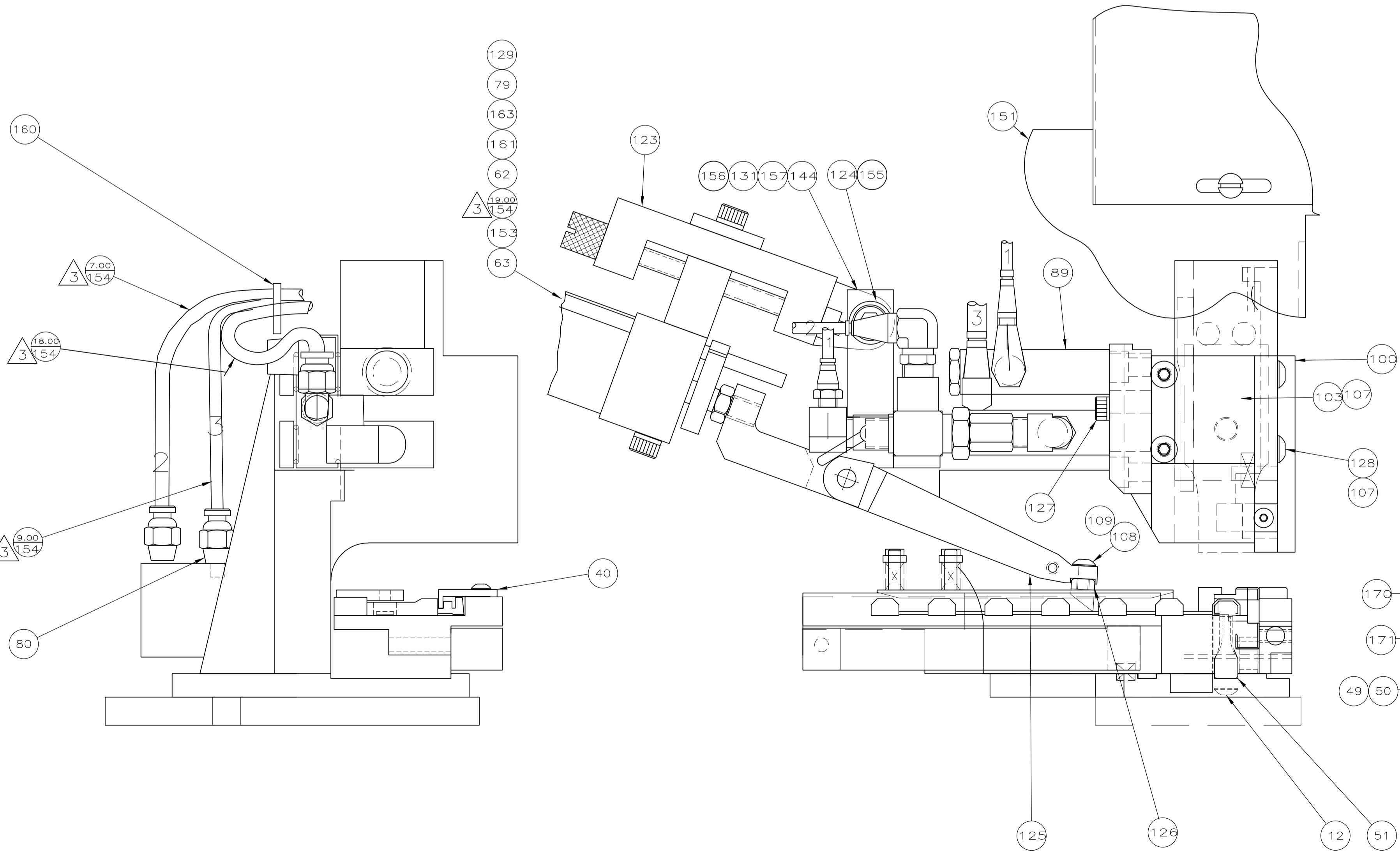

SEE DETAIL A

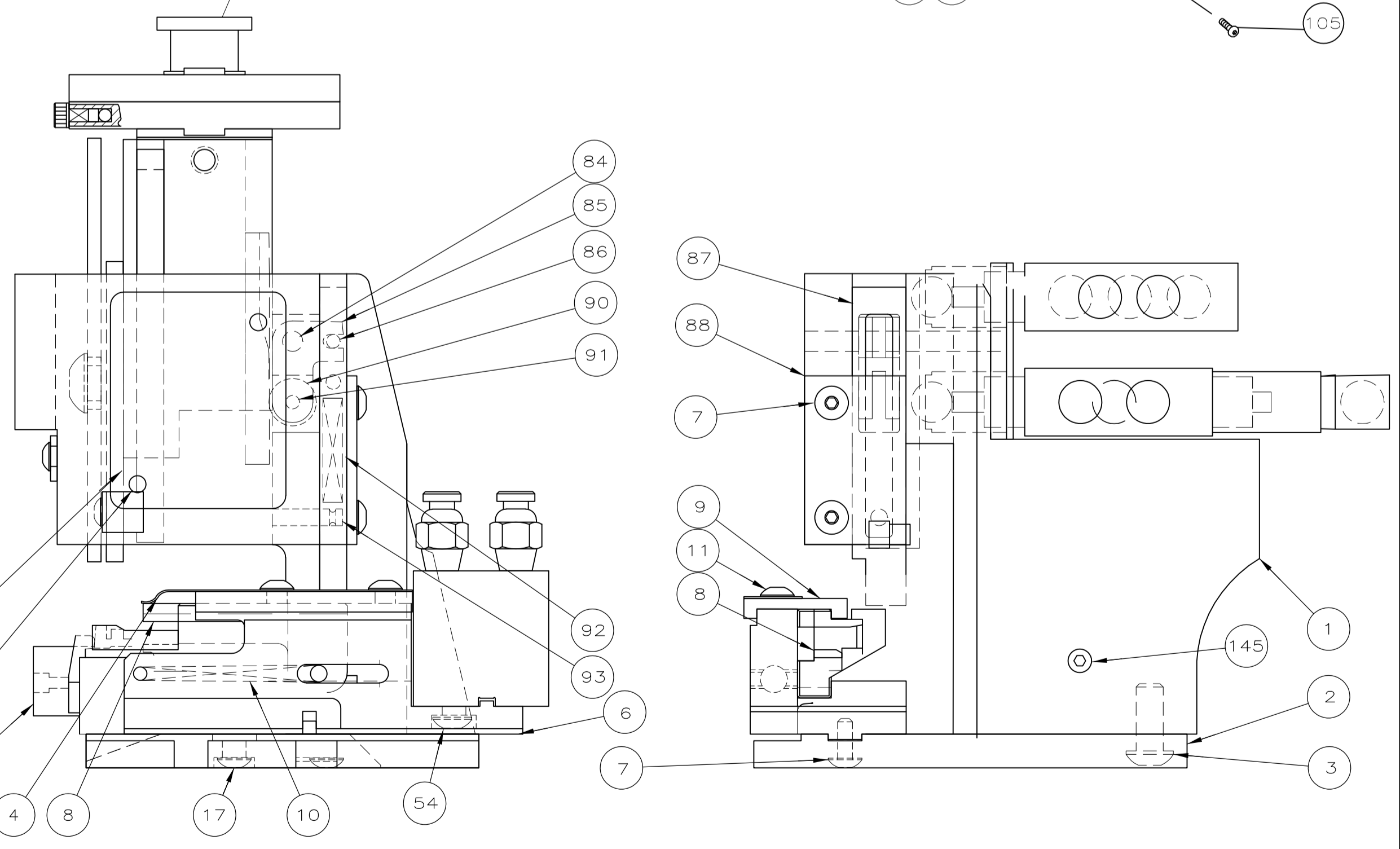

LOC A
DIST 66

REVISION RECORD	DATE	OWN	APVD
SEE SHEET 1			

DIMENSIONS:	TOLERANCES UNLESS OTHERWISE SPECIFIED:
INCHES	0 PLC ± .
	1 PLC ± .02
	2 PLC ± .05
	3 PLC ± .005
	4 PLC ± .0005

DWN	9-27-95	MATERIAL	HEAT TREAT
R O WILSON			
CHK	9-28-95		
C ERISMAN			
APVD	9-28-95		
A BEDDICK			
NAME	ULTRA-POD APPLICATOR .250 STRAIGHT		
SCALE	SIZE	DRAWING NO	SHEET
1:1	A1	1385719	2 of 3
		REV	H

CUSTOMER ACCESSIBLE PRODUCTION DRAWING

