

PROPERTY OF DEUTSCH E.C.D.

This drawing contains proprietary information that shall not be disclosed, duplicated, nor used in whole or in part for any purpose other than to evaluate this drawing.

DGA00*B**-EL***

REVISIONS			
REV	DESCRIPTION	DATE	APPROVED
-	NEW RELEASE DRAWING PER E.O. C7505	090115	M.A.

DG123		AF123		DG123A		DG123A	
CABLE CODE	INSERT ARR	CABLE CODE	INSERT ARR	CABLE CODE	INSERT ARR	CABLE CODE	INSERT ARR
10	08-04	72	10-03	38	09-35	59	21-35
11	10-03	73	10-05	39	09-98	60	21-41
12	10-05	74	14-04	40	11-05	61	23-21
13	10-12	75	14-09	41	11-35	62	23-35
14	14-04	76	14-19	42	11-99	63	23-53
15	14-09	77	16-07	43	13-04	64	23-55
16	14-19	78	16-14	44	13-35	65	25-04
17	14-37	79	16-27	45	13-98	66	25-19
18	16-07	80	18-09	46	15-05	67	25-20
19	16-14	81	18-21	47	15-18	68	25-24
20	16-27	82	18-38	48	15-35	69	25-29
21	16-55	83	20-11	49	15-97	70	25-35
22	18-09	84	20-24	50	17-06	71	25-61
23	18-21	85	20-45	51	17-08	92	11-98
24	18-38	86	22-14	52	17-26	93	15-19
25	18-85	87	22-32	53	17-35	94	13-08
26	20-11	88	22-61	54	19-11	95	17-99
27	20-24	89	24-19	55	19-32	96	21-39
28	20-45	90	24-41	56	19-35	97	25-43
29	20-92	91	24-74	57	21-11	101	17-04
30	22-14			58	21-16		
31	22-32						
32	22-61						
33	22-121						
34	24-19						
35	24-41						
36	24-74						
37	24-155						

△ DGA00 A B ** - EL ** *

INSERT TYPE: P = PIN
S = SOCKET
N = NO INSERT

CABLE INSERT ARRANGEMENT
SEE TABLE FOR COMPLETE LIST
00 = NO INSERT

TYPE: EL = ENVIRONMENTAL STRAIGHT

SHELL SIZE (SEE TABLE)

CONFIGURATION

FINISH: A = BLACK COMPOSITE UNPLATED
R = METALLIZED ADAPTER BODY

BASIC IDENTIFIER: DGA00 - DEUTSCH DG123 REAR ACCESSORIES

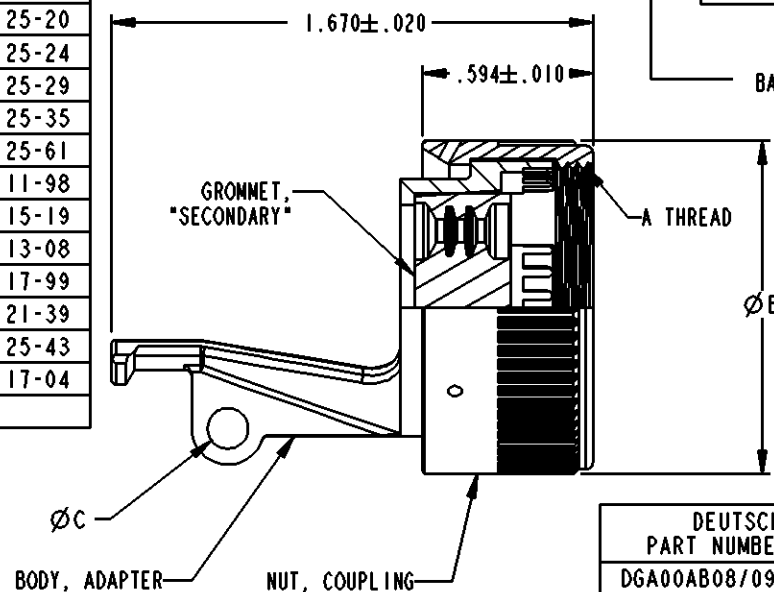

DEUTSCH PART NUMBER **	SHELL SIZE	A THREAD	B Ø ± .015	C Ø ± .010
DGA00AB08/09-EL***	08/09	.500-28UNEF-2B MOD	.650	.120
DGA00AB10/11-EL***	10/11	.625-28UN-2B MOD	.775	.120
DGA00AB13-EL***	13	.750-28UN-2B MOD	.905	.120
DGA00AB14/15-EL***	14/15	.875-28UN-2B MOD	1.030	.120
DGA00AB16/17-EL***	16/17	1.000-28UN-2B MOD	1.160	.140
DGA00AB18/19-EL***	18/19	1.125-28UN-2B MOD	1.270	.140
DGA00AB20/21-EL***	20/21	1.250-28UN-2B MOD	1.400	.140
DGA00AB22/23-EL***	22/23	1.375-28UN-2B MOD	1.525	.140
DGA00AB24/25-EL***	24/25	1.500-28UN-2B MOD	1.655	.140

△ FOR PART NUMBER BREAKDOWN, SEE TABLE.

- RECOMMENDED TORQUE: SHELL SIZES 08-16: 20-30 IN./LBS.
SHELL SIZES 18-24: 35-45 IN./LBS.
- MATERIAL: COUPLING NUT: COMPOSITE
ADAPTER BODY: COMPOSITE
SECONDARY GRONMET: SILICONE ELASTOMER
- CONSULT FACTORY FOR AVAILABILITY.
- ALL DIMENSIONS ARE IN INCHES UNLESS OTHERWISE SPECIFIED.

SIGNATURE & DATE	
DR	E. ALAWNEH 081222
CHK	M.A. 090114
PE	E. ALAWNEH 081222
APPD	A. RENGIFO 090115
SCALE	NONE WT

STRAIN RELIEF
STRAIGHT ONE ARM STYLE
LIGHT DUTY
DGA SERIES

ENVELOPE

CP

DEUTSCH
ENGINEERED CONNECTING DEVICES
5733 W. Whittier Ave.
Hemet, California

DGA00*B**-EL***

CODE 11139 SHEET | OF |