

- NOTES:
1. MATERIAL:
HOUSING: THERMAL PLASTIC, GLASS FILLED, UL94V-0, COLOR: BLACK.
TERMINAL: COPPER ALLOY, THICKNESS=0.25MM.
 2. TERMINAL PLATING:
CONTACT AREA: GOLD PLATED, SEE TABLE.
SOLDER AREA: PURE TIN, THICKNESS=1.27 MICRONS MINIMUM.
UNDER PLATE: NICKLE, THICKNESS=1.27 MICRONS MINIMUM.
 3. PRODUCT SPECIFICATION: REFER TO PS-47362-001.
 4. PACKAGING METHOD: REFER TO PK-47362-001.
 5. PRODUCT COMPLIANT TO RoHS DIRECTIVE 2002/95/EC AND ELV DIRECTIVE 2000/53/EC

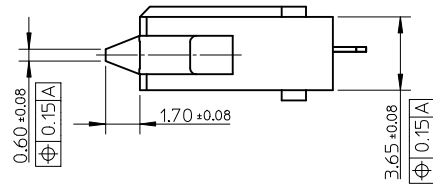
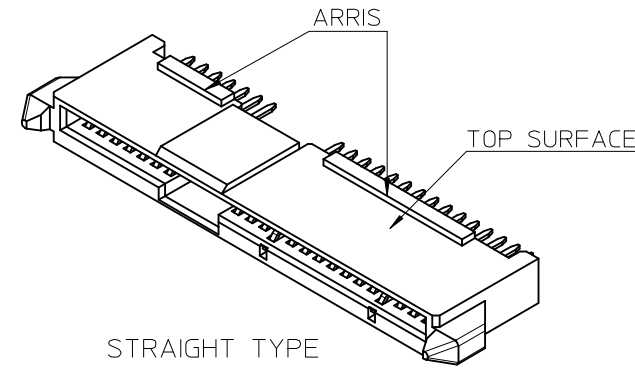

REVISED EC NO: S2017-0394 DRW: DBFAN 2017/01/09 CHKD: IKACHLIC 2017/01/09 APPR: IKACHLIC 2017/01/17	QUALITY SYMBOLS F=0 F=0 F=0	GENERAL TOLERANCES (UNLESS SPECIFIED)		DIMENSION STYLE MM ONLY		SCALE 4:1	DESIGN UNITS METRIC	THIRD ANGLE PROJECTION																				
		<table border="1"> <thead> <tr> <th></th> <th>mm</th> <th>INCH</th> </tr> </thead> <tbody> <tr> <td>4 PLACES</td> <td>± ---</td> <td>± ---</td> </tr> <tr> <td>3 PLACES</td> <td>± ---</td> <td>± ---</td> </tr> <tr> <td>2 PLACES</td> <td>± ---</td> <td>± ---</td> </tr> <tr> <td>1 PLACE</td> <td>± ---</td> <td>± ---</td> </tr> <tr> <td>0 PLACE</td> <td>± ---</td> <td>± ---</td> </tr> </tbody> </table>			mm	INCH	4 PLACES	± ---	± ---	3 PLACES	± ---	± ---	2 PLACES	± ---	± ---	1 PLACE	± ---	± ---	0 PLACE	± ---	± ---	DRAWN BY GLL I		DATE 2014/12/04	TITLE COMBO OF SATA & SAS RECEPTACLE CABLE END			
			mm	INCH																								
		4 PLACES	± ---	± ---																								
3 PLACES	± ---	± ---																										
2 PLACES	± ---	± ---																										
1 PLACE	± ---	± ---																										
0 PLACE	± ---	± ---																										
DRAFT WHERE APPLICABLE MUST REMAIN WITHIN DIMENSIONS		MATERIAL NO. SEE CHART IN SHEET 5		APPROVED BY DATE		DOCUMENT NO. SD-47363-100																						
REV K		DESCRIPTION REV		SIZE A3		SHEET NO. 1 OF 5																						

10 9 8 7 6 5 4 3 2 1

F

E

D

C

B

A

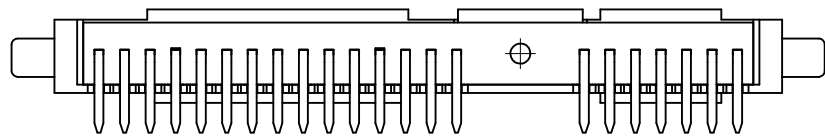

COVER

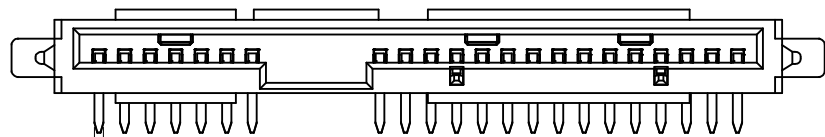
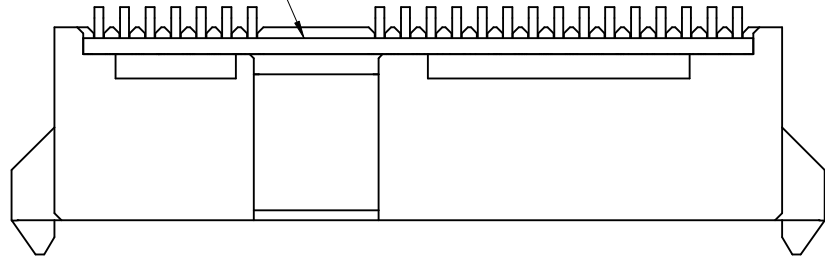

0.45 ± 0.05 (22X)
 \varnothing 0.15 B

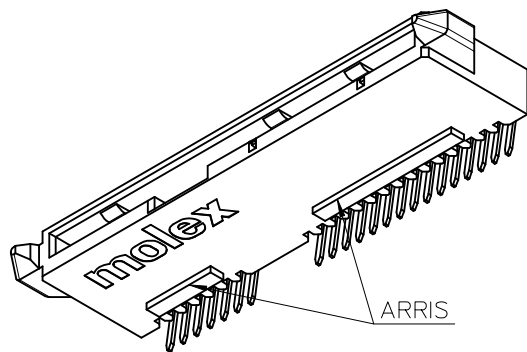

RIGHT ANGLE 90 DEGREE TYPE
 OTHER DIMENSIONS REFER TO STRAIGHT TYPE

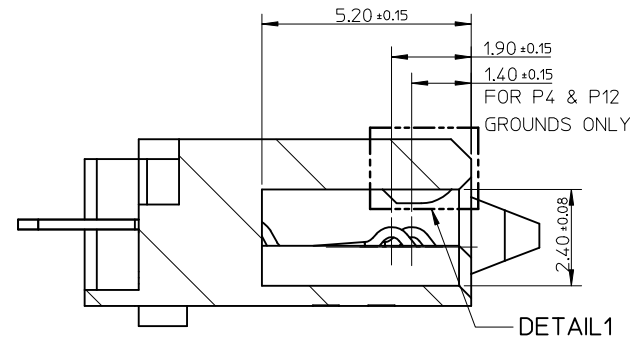

SECTION Z-Z

5.20 ± 0.15
 1.90 ± 0.15
 1.40 ± 0.15
 FOR P4 & P12
 GROUNDS ONLY

DETAIL1

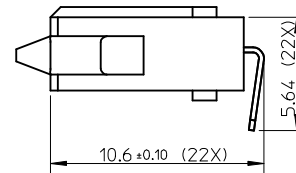

10.6 ± 0.10 (22X)

5.64 (22X)

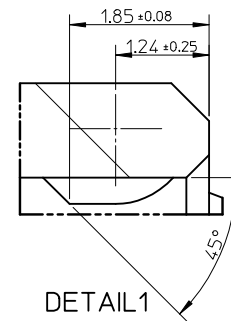

DETAIL1

SEE SHEET 1 EC NO: S2017-0394 DRWN:DBFAN 2017/01/09 CHKD:JKACHLIC 2017/01/09 APPR:JKACHLIC 2017/01/17	REV	QUALITY SYMBOLS	GENERAL TOLERANCES (UNLESS SPECIFIED)		DIMENSION STYLE	SCALE	DESIGN UNITS	THIRD ANGLE PROJECTION		
			mm	INCH	MM ONLY	4:1	METRIC			
		$\nabla_{\sqrt{3}}=0$	4 PLACES	± ---	± ---	DRAWN BY	DATE	TITLE		
		$\nabla_{\sqrt{6}}=0$	3 PLACES	± ---	± ---	CHECKED BY	DATE	COMBO OF SATA & SAS RECEPTACLE CABLE END		
$\nabla_{\sqrt{9}}=0$	2 PLACES	± ---	± ---	GLL I	2014/12/04	molex				
	1 PLACE	± ---	± ---	APPROVED BY	DATE				DOCUMENT NO.	
	0 PLACE	± ---	± ---	MATERIAL NO.		SD-47363-100		2 OF 5		
DRAFT WHERE APPLICABLE MUST REMAIN WITHIN DIMENSIONS			ANGULAR ± 3 °		SEE CHART IN SHEET 5					
					SIZE	THIS DRAWING CONTAINS INFORMATION THAT IS PROPRIETARY TO MOLEX INCORPORATED AND SHOULD NOT BE USED WITHOUT WRITTEN PERMISSION				
					A3					

9 8 7 6 5 4 3 2 1

10 9 8 7 6 5 4 3 2 1

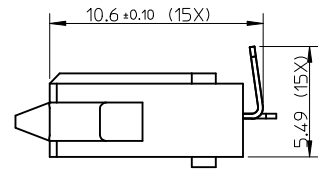
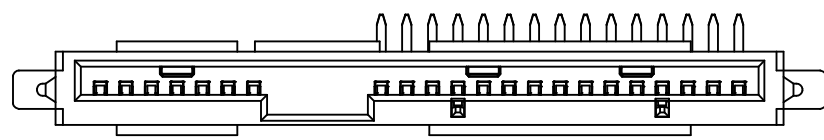
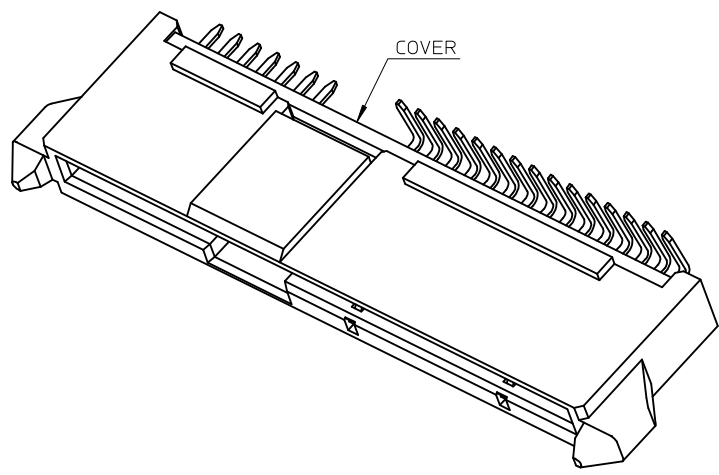
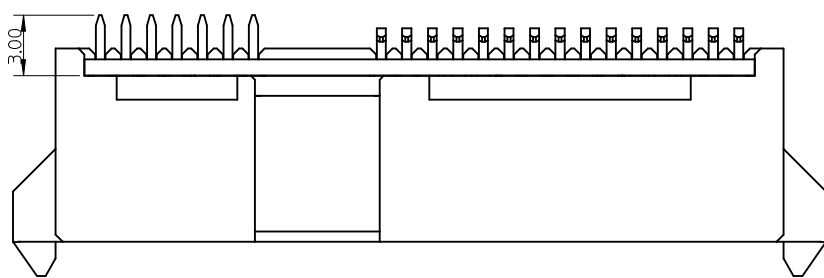

COMPOSITE TYPE
OTHER DIMENSIONS REFER TO STRAIGHT TYPE OR RIGHT ANGLE 90 DEGREE TYPE.

SEE SHEET 1 IEC NO: S2017-0394 DRW:DBFAN CHKD:JKACHLIC 2017/01/09 APPR:JKACHLIC 2017/01/17	DESCRIPTION REV	QUALITY SYMBOLS	GENERAL TOLERANCES (UNLESS SPECIFIED)	DIMENSION STYLE	SCALE	DESIGN UNITS	THIRD ANGLE PROJECTION	
		$\nabla_F = 0$ $\nabla_E = 0$ $\nabla_B = 0$	mm INCH 4 PLACES ± --- ± --- 3 PLACES ± --- ± --- 2 PLACES ± --- ± --- 1 PLACE ± --- ± --- 0 PLACE ± --- ± ---	MM ONLY	4:1	METRIC	DRAWN BY: GLL I DATE: 2014/12/04 CHECKED BY: GLL I DATE: 2014/12/04 APPROVED BY: DATE:	TITLE
		ANGULAR ± 3 ° DRAFT WHERE APPLICABLE MUST REMAIN WITHIN DIMENSIONS	MATERIAL NO. SEE CHART IN SHEET 5	DOCUMENT NO. SD-47363-100	SHEET NO. 3 OF 5			
		THIS DRAWING CONTAINS INFORMATION THAT IS PROPRIETARY TO MOLEX INCORPORATED AND SHOULD NOT BE USED WITHOUT WRITTEN PERMISSION						

COMBO OF
SATA & SAS RECEPTACLE
CABLE END

molex

9 8 7 6 5 4 3 2 1

10 9 8 7 6 5 4 3 2 1

F

E

D

C

B

A

F

E

D

C

B

A

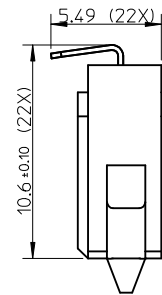
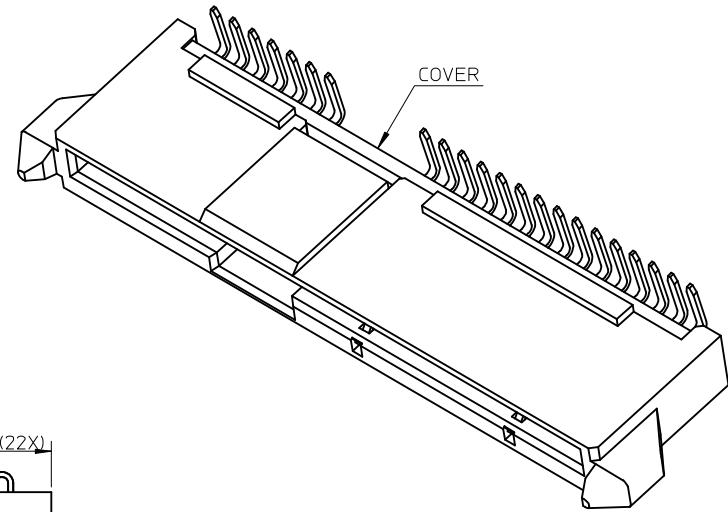
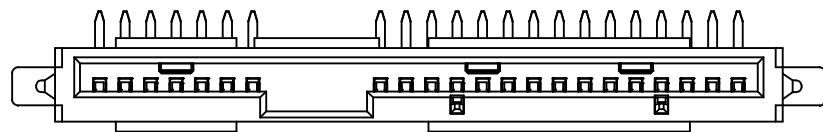
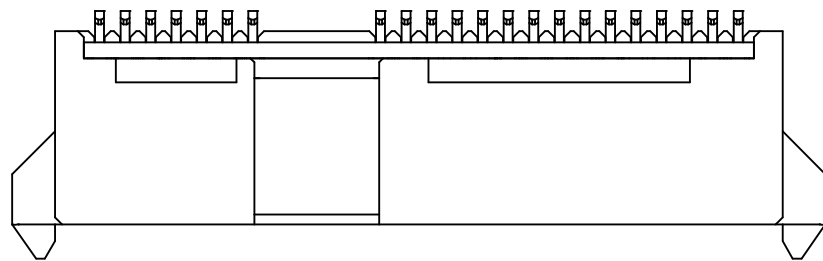
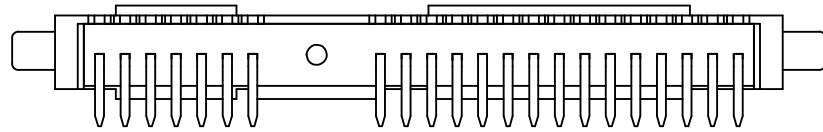

RIGHT ANGLE 270 DEGREE TYPE
OTHER DIMENSIONS REFER TO RIGHT ANGLE 90 DEGREE TYPE.

SEE SHEET 1 EC NO: S2017-0394 DRWN: DBFAN 2017/01/09 CHKD: JKACHLIC 2017/01/09 APPR: JKACHLIC 2017/01/17 K	DESCRIPTION REV	QUALITY SYMBOLS	GENERAL TOLERANCES (UNLESS SPECIFIED)	DIMENSION STYLE MM ONLY	SCALE 4:1	DESIGN UNITS METRIC	THIRD ANGLE PROJECTION																															
		$\nabla_{\text{A}} = 0$ $\nabla_{\text{C}} = 0$ $\nabla_{\text{P}} = 0$	<table border="1"> <thead> <tr> <th></th> <th>mm</th> <th>INCH</th> </tr> </thead> <tbody> <tr> <td>4 PLACES</td> <td>± ---</td> <td>± ---</td> </tr> <tr> <td>3 PLACES</td> <td>± ---</td> <td>± ---</td> </tr> <tr> <td>2 PLACES</td> <td>± ---</td> <td>± ---</td> </tr> <tr> <td>1 PLACE</td> <td>± ---</td> <td>± ---</td> </tr> <tr> <td>0 PLACE</td> <td>± ---</td> <td>± ---</td> </tr> </tbody> </table>		mm	INCH	4 PLACES	± ---	± ---	3 PLACES	± ---	± ---	2 PLACES	± ---	± ---	1 PLACE	± ---	± ---	0 PLACE	± ---	± ---	<table border="1"> <thead> <tr> <th>DRAWN BY</th> <th>DATE</th> <th>TITLE</th> </tr> </thead> <tbody> <tr> <td>GLL I</td> <td>2014/12/04</td> <td rowspan="3">COMBO OF SATA & SAS RECEPTACLE CABLE END</td> </tr> <tr> <td>CHECKED BY</td> <td>DATE</td> </tr> <tr> <td>GLL I</td> <td>2014/12/04</td> </tr> <tr> <td>APPROVED BY</td> <td>DATE</td> <td></td> </tr> </tbody> </table>	DRAWN BY	DATE	TITLE	GLL I	2014/12/04	COMBO OF SATA & SAS RECEPTACLE CABLE END	CHECKED BY	DATE	GLL I	2014/12/04	APPROVED BY	DATE				
			mm	INCH																																		
		4 PLACES	± ---	± ---																																		
3 PLACES	± ---	± ---																																				
2 PLACES	± ---	± ---																																				
1 PLACE	± ---	± ---																																				
0 PLACE	± ---	± ---																																				
DRAWN BY	DATE	TITLE																																				
GLL I	2014/12/04	COMBO OF SATA & SAS RECEPTACLE CABLE END																																				
CHECKED BY	DATE																																					
GLL I	2014/12/04																																					
APPROVED BY	DATE																																					
		ANGULAR ± 3 °	MATERIAL NO.	DOCUMENT NO.			SHEET NO.																															
		DRAFT WHERE APPLICABLE MUST REMAIN WITHIN DIMENSIONS	SEE CHART IN SHEET 5	SD-47363-100			4 OF 5																															

9 8 7 6 5 4 3 2 1

	10	9	8	7	6	5	4	3	2	1
F	47363-4032	0.38 MICRONS MIN. GOLD PLATING	WITHOUT ARRIS	RIGHT ANGLE TYPE 270 DEGREE	WITH HALOGEN					
	47363-4031	0.76 MICRONS MIN. GOLD PLATING	WITH COVER							
	47363-4030	GOLD FLASH								
	47363-4022	0.38 MICRONS MIN. GOLD PLATING	WITH ARRIS ON BOTTOM SURFACE							
	47363-4021	0.76 MICRONS MIN. GOLD PLATING	WITH COVER							
	47363-4020	GOLD FLASH								
	47363-4012	0.38 MICRONS MIN. GOLD PLATING	WITH ARRIS ON TOP SURFACE							
	47363-4011	0.76 MICRONS MIN. GOLD PLATING	WITH COVER							
	47363-4010	GOLD FLASH								
	47363-4042	0.76 MICRONS MIN. GOLD PLATING	WITH ARRIS ON BOTH SURFACE							
E	47363-4001	0.76 MICRONS MIN. GOLD PLATING	WITH COVER	COMPOSITE TYPE						
	47363-4000	GOLD FLASH								
	47363-3032	0.38 MICRONS MIN. GOLD PLATING	WITHOUT ARRIS							
	47363-3031	0.76 MICRONS MIN. GOLD PLATING	WITH COVER							
	47363-3030	GOLD FLASH								
	47363-3022	0.38 MICRONS MIN. GOLD PLATING	WITH ARRIS ON BOTTOM SURFACE							
	47363-3021	0.76 MICRONS MIN. GOLD PLATING	WITH COVER							
	47363-3020	GOLD FLASH								
	47363-3012	0.38 MICRONS MIN. GOLD PLATING	WITH ARRIS ON TOP SURFACE							
	47363-3011	0.76 MICRONS MIN. GOLD PLATING	WITH COVER							
D	47363-3010	GOLD FLASH		RIGHT ANGLE TYPE 90 DEGREE						
	47363-3001	0.76 MICRONS MIN. GOLD PLATING	WITH ARRIS ON BOTH SURFACE							
	47363-3000	GOLD FLASH	WITH COVER							
	47363-2032	0.38 MICRONS MIN. GOLD PLATING	WITHOUT ARRIS							
	47363-2031	0.76 MICRONS MIN. GOLD PLATING	WITH COVER							
	47363-2030	GOLD FLASH								
	47363-2022	0.38 MICRONS MIN. GOLD PLATING	WITH ARRIS ON BOTTOM SURFACE							
	47363-2021	0.76 MICRONS MIN. GOLD PLATING	WITH COVER							
	47363-2020	GOLD FLASH								
	47363-2012	0.38 MICRONS MIN. GOLD PLATING	WITH ARRIS ON TOP SURFACE							
C	47363-2011	0.76 MICRONS MIN. GOLD PLATING	WITH COVER	STRAIGHT TYPE						
	47363-2010	GOLD FLASH								
	47363-2001	0.76 MICRONS MIN. GOLD PLATING	WITH ARRIS ON BOTH SURFACE							
	47363-2000	GOLD FLASH	WITH COVER							
	47363-1031	0.76 MICRONS MIN. GOLD PLATING	WITHOUT ARRIS							
	47363-1030	GOLD FLASH								
	47363-1022	0.38 MICRONS MIN. GOLD PLATING								
	47363-1021	0.76 MICRONS MIN. GOLD PLATING	WITH ARRIS ON BOTTOM SURFACE							
	47363-1020	GOLD FLASH								
	47363-1012	0.38 MICRONS MIN. GOLD PLATING								
B	47363-1011	0.76 MICRONS MIN. GOLD PLATING	WITH ARRIS ON TOP SURFACE							
	47363-1010	GOLD FLASH								
	47363-1041	0.76 MICRONS MIN. GOLD PLATING	WITH ARRIS ON BOTH SURFACE							
	47363-1000	GOLD FLASH								

47363-3101	0.76 MICRONS MIN. GOLD PLATING	WITH ARRIS ON BOTH SURFACE	COMPOSITE TYPE	HALOGEN FREE
47363-3100	GOLD FLASH	WITH COVER		
P/N	CONTACT AREA PLATING	REMARK	TYPE	DESCRIPTION

A	SEE SHEET 1 EC NO: S2017-0394 DRW:DBFAN CHKD:JKACHLIC APPR:JKACHLIC 2017/01/09 2017/01/17	QUALITY SYMBOLS ▽F=0 ▽E=0 ▽D=0	DESCRIPTION REV	GENERAL TOLERANCES (UNLESS SPECIFIED)		DIMENSION STYLE MM ONLY		SCALE 4:1	DESIGN UNITS METRIC	THIRD ANGLE PROJECTION	
					mm	INCH	DRAWN BY GLL I		DATE 2014/12/04	TITLE COMBO OF SATA & SAS RECEPTACLE CABLE END	
				4 PLACES	± ---	± ---	CHECKED BY GLL I		DATE 2014/12/04	molex	
				3 PLACES	± ---	± ---	APPROVED BY		DATE		
2 PLACES	± ---	± ---	MATERIAL NO.		DOCUMENT NO.	SHEET NO.					
1 PLACE	± ---	± ---	DRAFT WHERE APPLICABLE MUST REMAIN WITHIN DIMENSIONS		SEE CHART		SD-47363-100		5 OF 5		
0 PLACE	± ---	± ---	ANGULAR ± 3 °		THIS DRAWING CONTAINS INFORMATION THAT IS PROPRIETARY TO MOLEX INCORPORATED AND SHOULD NOT BE USED WITHOUT WRITTEN PERMISSION						