

## Specification

**Small Form Factor Pluggable**

Duplex LC Receptacle – SFP+

**Optical Transceivers**

10 Gigabit Ethernet

10GBASE-LR



## Ordering Information

# TAS-A5NB1-FAH

Model Name	Voltage	Category	Device type	Interface	LOS	Temperature	Distance	Latch Color
TAS-A5NB1-FAH	3.3V	With DDMI	1310 nm DFB	AC / AC Coupling	LVTTL	-5°C~+70°C	10km	Blue 

## Features

- Optical Interface compliant to IEEE 802.3ae 10GBASE-LR/LW
- Compliant with SFP+ MSA
- Data Rate 10.3125Gbps
- 1310nm DFB TOSA and PIN ROSA
- Applicable for 10 km SMF connection
- LC duplex receptacle
- Low power dissipation (< 1W)
- Hot Pluggable
- All-metal housing for superior EMI performance
- Built in digital diagnostic Functions
- ROHS Compliant

## Applications

- 10GBASE-LR 10Gigabit Ethernet
- High-speed storage area networks
- Computer cluster cross-connect
- Custom high-speed data pipes

## Transceiver Block Diagram

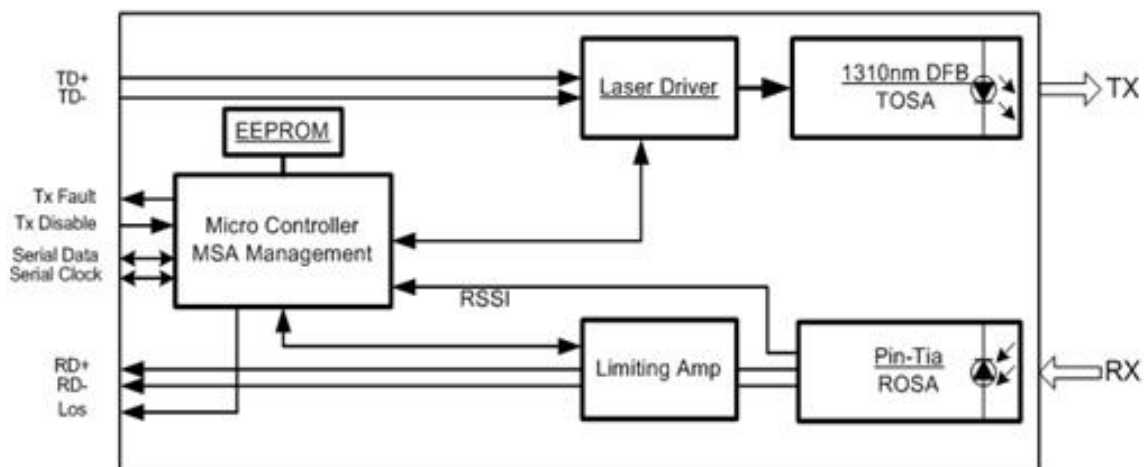

Proposed Applications Schematics

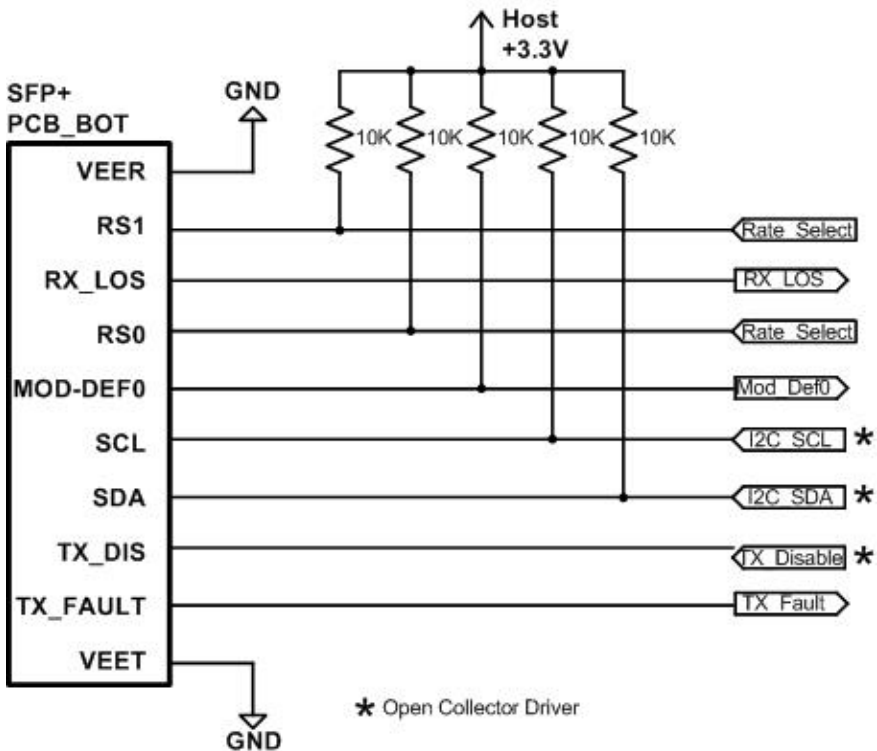
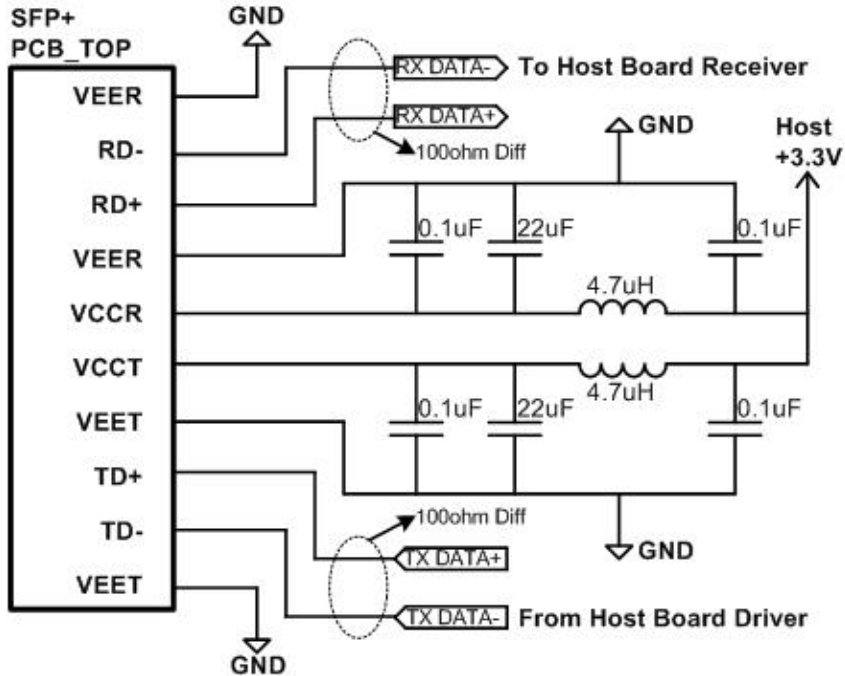

### Pin Definition and Descriptions

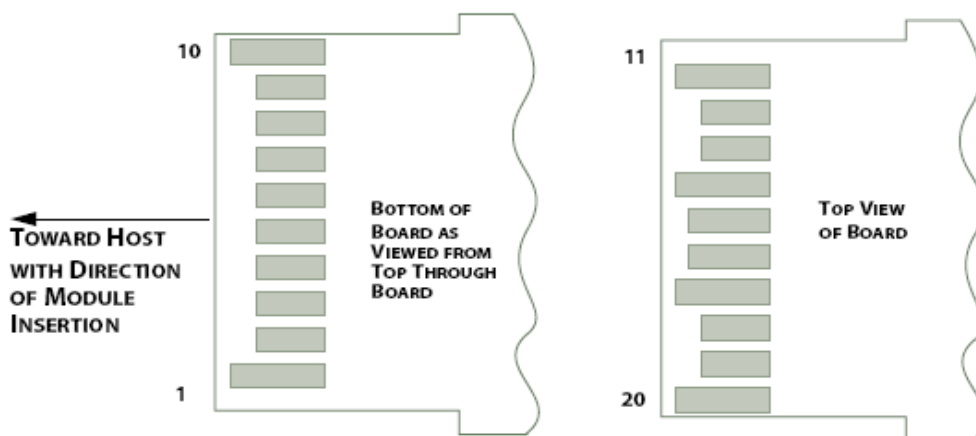
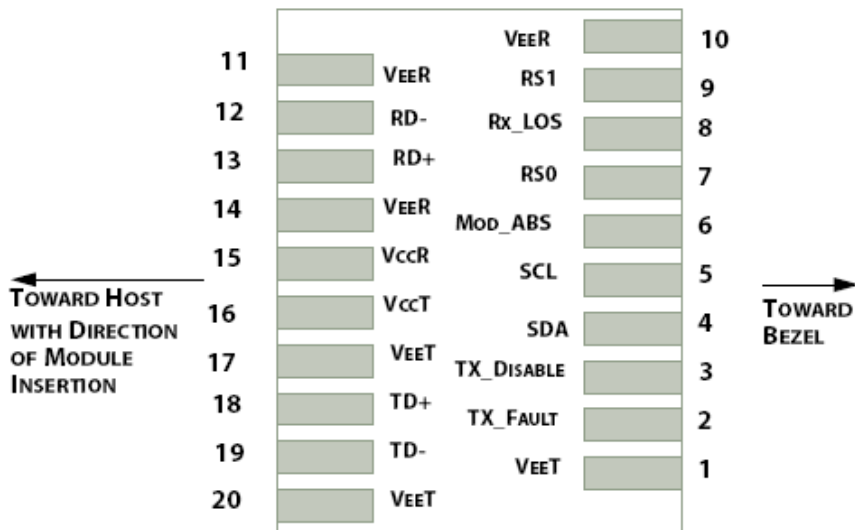

PIN	Logic	Symbol	Name / Description	Note
1		VeeT	Module Transmitter Ground	1
2	LVTTL-O	TX_Fault	Module Transmitter Fault	2
3	LVTTL-I	TX_Dis	Transmitter Disable; Turns off transmitter laser output	3
4	LVTTL-I/O	SDA	2-Wire Serial Interface Data Line	
5	LVTTL-I	SCL	2-Wire Serial Interface Clock	
6		Mod_ABS	Module Absent, connected to VeeT or VeeR in the module	
7	LVTTL-I	RS0	Rate Select 0, optionally controls SFP+ module receiver. When high input signaling rate > 4.25 GBd and when low input signal rate $\leq$ 4.25 GBd.	
8	LVTTL-O	RX_LOS	Receiver Loss of Signal Indication	
9	LVTTL-I	RS1	Rate Select 1, optionally controls SFP+ module transmitter. When high input signaling rate > 4.25 GBd and when low input signal rate $\leq$ 4.25 GBd.	
10		VeeR	Module Receiver Ground	1
11		VeeR	Module Receiver Ground	1
12	CML-O	RD-	Receiver Inverted Data Output	
13	CML-O	RD+	Receiver Data Output	
14		VeeR	Module Receiver Ground	1
15		VccR	Module Receiver 3.3 V Supply	
16		VccT	Module Transmitter 3.3 V Supply	
17		VeeT	Module Transmitter Ground	1
18	CML-I	TD+	Transmitter Non-Inverted Data Input	
19	CML-I	TD-	Transmitter Inverted Data Input	
20		VeeT	Module Transmitter Ground	1

**Note:**

1. Module ground pins are isolated from the module case and chassis ground within the module.
2. Shall be pulled up with 4.7k to 10k ohm to a voltage between 3.15V and 3.45V on the host board.
3. Shall be pulled up with 4.7k to 10k ohm to VccT in the module.

### Absolute Maximum Ratings

Parameters	Symbol	Min.	Max.	Unit
Power Supply Voltage	V <sub>CC</sub>	0	3.6	V
Storage Temperature	T <sub>c</sub>	-40	85	°C
Relative Humidity	RH	5	95	%
Optical Receiver Power (Damage)	P <sub>max</sub>		1.5	dBm

### Recommended Operating Environment

Parameters	Symbol	Min.	Typical	Max	Unit
Power Supply Voltage	V <sub>CC</sub>	3.135	3.3	3.465	V
Operating Case Temperature	T <sub>c</sub>	-5		70	°C
Power Supply Current	I <sub>CC</sub>			300	mA
Power Consumption			800	1000	mW
Data rate			10.3125		Gbps

### Optical Characteristics

Parameter	Symbol	Min.	Typ.	Max	Unit	Notes
<b>Transmitter</b>						
Average Launch Power	P <sub>o</sub>	-8.2	---	0.5	dBm	
Center wavelength	λ <sub>c</sub>	1260	---	1355	nm	
Side Mode Suppression Ratio	SMSR	30	---	---	nm	
Extinction ratio	E <sub>R</sub>	3.5	---	---	dB	
Transmitter and dispersion penalty(max)	TDP	---	---	3.2	dB	
Optical power OMA	P <sub>OMA</sub>	-5.2	---	---	dBm	
OMA-TDP	P <sub>OMA-TDP</sub>	-6.2	---	---	dBm	
Average launch power of OFF transmitted	P <sub>off</sub>	---	---	-30	dBm	
RIN <sub>1/2</sub> OMA	RIN	---	---	-128	dB/Hz	
Optical Return Loss Tolerance		12	---	---	dB	
Output eye	Compliant with IEEE802.3ae eye mask					
<b>Receiver</b>						
Center wavelength	λ <sub>c</sub>	1260		1355	nm	
Average receiver power(max)	P <sub>max</sub>			0.5	dBm	
Average receiver power(min)	P <sub>min</sub>	-14.4			dBm	
Receiver Reflectance	R <sub>rx</sub>			-12	dB	
Receiver Sensitivity in OMA				-12.6	dBm	
Stressed Sensitivity in OMA				-10.3	dBm	1
Vertical eye closure penalty		2.2			dB	2
Stressed eye jitter		0.3			Ulp-p	1
LOS	Assert	LOS <sub>A</sub>	-30		dBm	
	Deassert	LOS <sub>D</sub>		-12	dBm	
LOS Hysteresis	LOS <sub>H</sub>	0.5			dB	

**Note:**

1. Receiver sensitivity is informative. Stressed receiver sensitivity shall be measured with conformance test signal for BER =  $1 \times 10^{-12}$ .
2. Vertical eye closure penalty and stressed eye jitter are the test conditions for measuring stressed receiver sensitivity. They are not the required characteristic of the receiver.

### Electrical Characteristics

Parameter	Symbol	Min.	Typical	Max	Unit	Notes
Data Rate		-	10.3125	-	Gbps	
<b>Transmitter</b>						
Transmitter Differential Input Voltage	$V_{IN}$	180	-	700	mV	
Transmitter Disable (TX-Disable)	$V_{IH}$	2		$V_{CC}$	V	
	$V_{IL}$	$V_{EE}$		$V_{EE}+0.8$		
<b>Receiver</b>						
Receiver Differential Output Voltage	$V_O$	300	-	850	mV	
Loss of Signal (LOS)	$V_{OH}$	2		$V_{CC}$	V	
	$V_{OL}$	$V_{EE}$		$V_{EE}+0.8$		
Rx Output Rise and Fall Time	$T_r/T_f$	30			ps	20% to 80%

### Control And Status I/O Timing Characteristics

Parameter	Symbol	Min	Max	Unit	Condition
TX Disable Assert Time	$t_{off}$		10	$\mu s$	Time from rising edge of TX Disable to when the optical output falls below 10% of nominal
TX Disable Negate Time	$t_{on}$		1	ms	Time from falling edge of TX Disable to when the modulated optical output rises above 90% of nominal
Time to initialize, including reset of TX_Fault	$t_{init}$		300	ms	From power on or negation of TX Fault using TX Disable
TX Fault Assert Time	$t_{fault}$		100	$\mu s$	Time from fault to TX fault on.
TX Disable to reset	$t_{reset}$	10		$\mu s$	Time TX Disable must be held high to reset TX_fault
LOS Assert Time	$t_{loss\_on}$		100	$\mu s$	Time from LOS state to RX LOS assert
LOS Deassert Time	$t_{loss\_off}$		100	$\mu s$	Time from non-LOS state to RX LOS deassert
Rate-Select Change Time	$t_{ratesel}$		10	$\mu s$	Time from rising or falling edge of Rate Select input until receiver bandwidth is in conformance with appropriate specification.
Serial ID Clock Rate	$f_{serial\_clock}$		100	kHz	



### Digital Diagnostic Functions

Parameter	Symbol	Min.	Max	Unit	Notes
Temperature monitor absolute error	DMI_Temp	-3	3	degC	Over operating temp
Laser power monitor absolute error	DMI_TX	-3	3	dB	
RX power monitor absolute error	DMI_RX	-3	3	dB	-1dBm to -12dBm range
Supply voltage monitor absolute error	DMI_VCC	-0.08	0.08	V	Full operating range
Bias current monitor	DMI_Ibias	-10%	10%	mA	

### Digital Diagnostic Memory Map

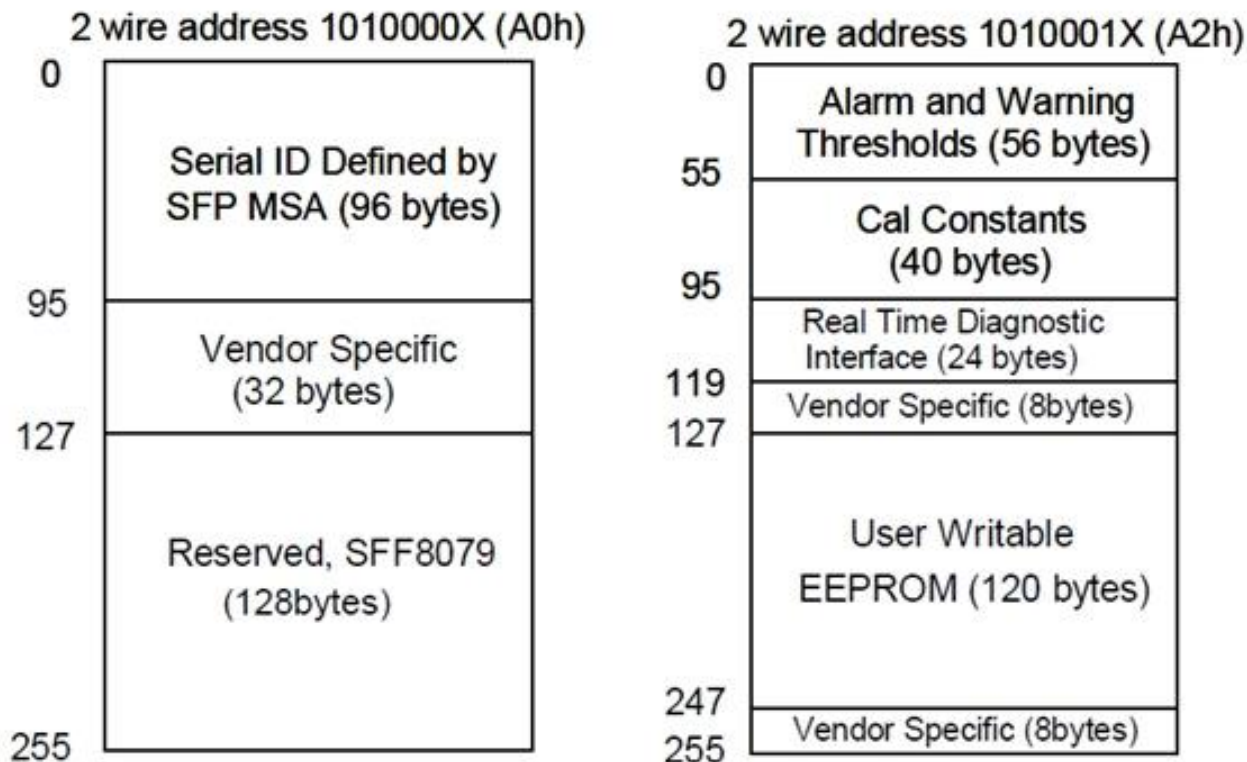



**Content in 2-Wire Address A0H**

Address	HEX	Name of Field	Description
00	03	Identifier	SFP
01	04	Extended Identifier	SFP
02	07	Connector type	LC
03	20	10G Ethernet Compliance Codes	10G Base LR
04	00	SONET Compliance Codes	Not compliant
05	00	SONET Compliance Codes	Not compliant
06	00	Ethernet Compliance Codes	Not compliant
07	00	Fiber Channel link length	Not compliant
08	00	Fiber Channel transmitter technology	Not compliant
09	00	Fiber Channel transmission media	Not compliant
10	00	Fiber Channel speed	Not compliant
11	06	Encoding codes:	64B/66B
12	67	Nominal Bit Rate (units of 100Mbps)	10.3Gbps
13	00	Rate identifier	Unspecified
14	0A	Link length supported for 9um fiber	10km (units of km)
15	64	Link length supported for 9um fiber	10km (units of 100m)
16	00	Link length supported for 50um,OM2	N/A (units of 10m)
17	00	Link length supported for 62.5um,OM1	N/A (units of 10m)
18	00	Link length supported for copper	N/A (units of 1m)
19	00	Link length supported for 50um,OM3	N/A (units of 10m)
20 ~ 35	46,4F,52,4D,45,52,49,43,41,4F,45,20,20,20,20,20	Vendor Name	FORMERICA OE
36	00	Unallocated	
37 ~ 39	00,00,00	Vendor OUI	Unspecified
40 ~ 55	54,41,53,2D,41,35,4E,42,31,2D,46,41,48,20,20,20	Part Number	TAS-A5NB1-FAH
56 ~ 59	00,00,00,00	Vendor Revision number	Unspecified
60 ~ 61	05,1E	Laser Wavelength	1310nm
62	00	Unallocated	
63		CC_BASE:	Check sum of byte 0 ~ 62
64	00	Options	
65	1A	Options	TX-DIS, TX_FAULT, RX-LOS
66	00	Bit Rate, max.	Unspecified
67	00	Bit Rate, min.	Unspecified
68 ~ 83	Serial Number	Serial Number	
84 ~ 89	yy/mm/dd	Date Code	
90 ~ 91	20,20	Vendor specific lot code	Unspecified
92	68	Diagnostic Monitoring Type	Internal calibration
93	F0	Enhanced Options (soft)	Alarm/Warning flags, Soft TxDisable, Soft TxFault, Soft RxLOS implemented
94	03	SFF-8472 Compliance	Rev10.2
95		CC_EXT	Check sum of byte 64 ~ 94
96~127		Vendor specific	



Content in 2-Wire Address A2H

Add	Bytes	Name	Hex	Real Value
00-01	2	Temp High Alarm	5500	85°C
02-03	2	Temp Low Alarm	F100	-15°C
04-05	2	Temp High Warning	5000	80°C
06-07	2	Temp Low Warning	F600	-10°C
08-09	2	Voltage High Alarm	9470	3.8V
10-11	2	Voltage Low Alarm	6D60	2.8V
12-13	2	Voltage High Warning	9088	3.7V
14-15	2	Voltage Low Warning	7148	2.9V
16-17	2	Bias High Alarm	AFC8	90mA
18-19	2	Bias Low Alarm	03E8	2mA
20-21	2	Bias High Warning	9C40	80mA
22-23	2	Bias Low Warning	05DC	3mA
24-25	2	TX Power High Alarm	576C	3.5dBm
26-27	2	TX Power Low Alarm	02F8	-11.2dBm
28-29	2	TX Power High Warning	4574	2.5dBm
30-31	2	TX Power Low Warning	03B6	-10.2dBm
32-33	2	RX Power High Alarm	576C	3.5dBm
34-35	2	RX Power Low Alarm	00E6	-16.4dBm
36-37	2	RX Power High Warning	4574	2.5dBm
38-39	2	RX Power Low Warning	016B	-14.4dBm
40-55	16	Reserved	FF	-
56-59	4	RX_PWR(4)	00000000	0
60-63	4	RX_PWR(3)	00000000	0
64-67	4	RX_PWR(2)	00000000	0
68-71	4	RX_PWR(1)	3F800000	1
72-75	4	RX_PWR(0)	00000000	0
76-77	2	TX_I(Slope)	0100	1
78-79	2	TX_I(Offset)	0000	0
80-81	2	TX_PWR(Slope)	0100	1
82-83	2	TX_PWR(Offset)	0000	0
84-85	2	T(Slope)	0100	1
86-87	2	T(Offset)	0000	0
88-89	2	V(Slope)	0100	1
90-91	2	V(Offset)	0000	0
92-94	3	Reserved	00	-
95	1	Checksum		-

### Mechanical (mm)

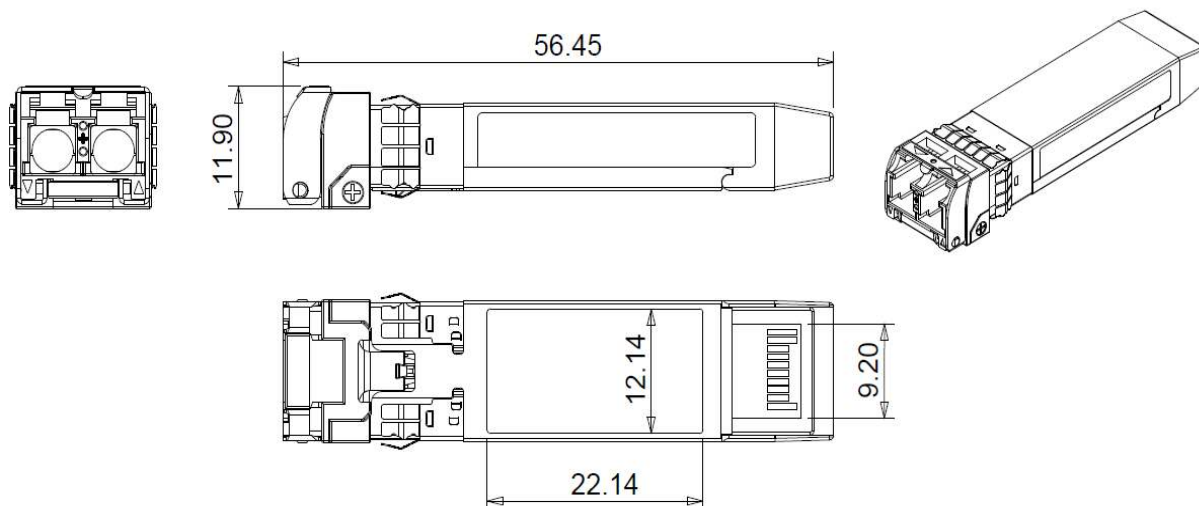

### ESD

This transceiver is specified as ESD threshold 2kV for all electrical input pins, tested per MIL-STD-883, Method 3015.4 /JESD22-A114-A (HBM). However, normal ESD precautions are still required during the handling of this module. This transceiver is shipped in ESD protective packaging. It should be removed from the packaging and handled only in an ESD protected environment.

### LASER Safety

This is a Class 1 Laser Product according to IEC 60825-1:1993:+A1:1997+A2:2001. This product complies with 21 CFR 1040.10 and 1040.11 except for deviations pursuant to Laser Notice No. 50, dated (July 26, 2001)