

10	9	8	7
MATERIAL	ENG-NUMBER	LENGTH	LENGTH TOL.
1300290003	405006D12M010	1M (3'-4")	+58.7MM -0(+2.31" -0")

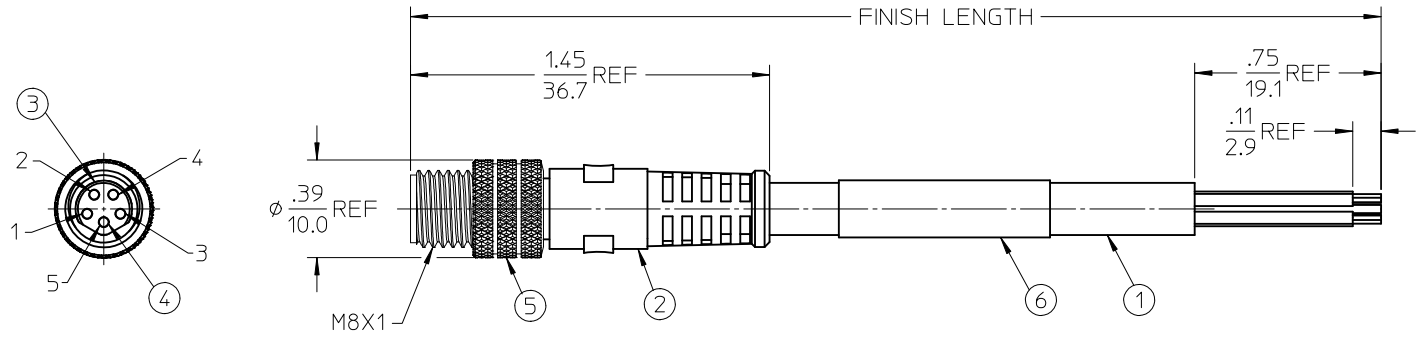
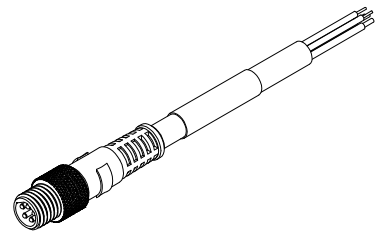

NOTES:

- 1.) MATERIAL: SEE TABLE
- 2.) FINISHES: SEE TABLE
- 3.) ELECTRICAL: 60VAC 75VDC, 1.68 AMPS
- 4.) CABLE:
TWO SHIELDED PAIRS
26AWG/ 4C 300VDC
-20 TO +70°C @ 1.68 AMPS
- 5.) IP67
- 6.) ASSEMBLY IS RoHS COMPLIANT

WIRING CONNECTION

1	BARE	DRAIN
2	RED	V+
3	WHITE	CAN_H
4	BLACK	V-
5	BLUE	CAN_L

6	1	MFG LABEL	PLASTIC FILM	BLACK/YELLOW
5	1	MALE COUPLING NUT	BRASS	NICKEL PLATED
4	5	MALE CONTACT	Cu ALLOY	GOLD PLATED
3	1	NC 5 POLE MALE INSERT	PUR	BLACK
2	1	OVERMOLD BODY	TPE	GRAY
1	1	CABLE, 4P, 26 AWG	PVC JACKET	GRAY
ITEM	QTY	DESCRIPTION	MATERIAL	FINISH

CREATE DOC.
EC NO: WNA2010-0452
DRAWN: BRUPERT 2010/01/25
CHKD: B. WOODMAN 2010/01/29
APPR: JFMURPHY 2010/01/29

QUALITY SYMBOLS
▽=0
▽=0

DESCRIPTION
REV A

GENERAL TOLERANCES (UNLESS SPECIFIED)

	mm	INCH
4 PLACES	± .005	± .0004
3 PLACES	± .003	± .0002
2 PLACES	± .002	± .0001
1 PLACE	± .001	± .00005

ANGULAR ±1/2°

DRAFT WHERE APPLICABLE
MUST REMAIN WITHIN DIMENSIONS

DIMENSION STYLE
IN/MM

SCALE
2:1

DESIGN UNITS
INCH

THIRD ANGLE PROJECTION

TITLE
NC 5P STR MALE DEVICENET

DRAWN BY
B. RUPERT

DATE
01/15/2010

CHECKED BY
B. WOODMAN

DATE
01/15/2010

APPROVED BY
JFMURPHY

DATE
2010/01/29

MATERIAL NO.
SEE CHART

DOCUMENT NO.
SD-130029-003

SHEET NO.
1 OF 1

THIS DRAWING CONTAINS INFORMATION THAT IS PROPRIETARY TO MOLEX INCORPORATED AND SHOULD NOT BE USED WITHOUT WRITTEN PERMISSION