



# **Future Technology Devices International Ltd**

## **USB TO RS422 UART SERIAL CONVERTER PCB**

### **Datasheet**

**Document Reference No.: FT\_000119**

**Version 1.02**

**Issue Date: 13-04-09**

#### **Future Technology Devices International Limited (FTDI)**

Unit1, 2 Seaward Place, Centurion Business Park,, Glasgow G41 1HH United Kingdom

Tel.: +44 (0) 141 429 2777 Fax: + 44 (0) 141 429 2758

E-Mail (Support): [support1@ftdichip.com](mailto:support1@ftdichip.com) Web: <http://www.ftdichip.com>

Copyright © 2008 Future Technology Devices International Limited

Neither the whole nor any part of the information contained in, or the product described in this manual, may be adapted or reproduced in any material or electronic form without the prior written consent of the copyright holder. This product and its documentation are supplied on an as-is basis and no warranty as to their suitability for any particular purpose is either made or implied. Future Technology Devices International Ltd will not accept any claim for damages howsoever arising as a result of use or failure of this product. Your statutory rights are not affected. This product or any variant of it is not intended for use in any medical appliance, device or system in which the failure of the product might reasonably be expected to result in personal injury. This document provides preliminary information that may be subject to change without notice. No freedom to use patents or other intellectual property rights is implied by the publication of this document. Future Technology Devices International Ltd, Unit1, 2 Seaward Place, Centurion Business Park, Glasgow, G41 1HH, United Kingdom. Scotland Registered Number: SC136640

## 1 Description

The **USB-RS422-PCB** is a USB to RS422 level serial UART converter PCB incorporating FTDI's FT232RQ USB to Serial UART interface IC device which handles all the USB signalling and protocols. The PCB provides a fast, simple way to connect devices with a RS422 interface to USB.

Each USB-RS422-PCB contains a small internal electronic circuit board, utilising the FT232R plus a USB type-A connector. The FT232R datasheet, DS\_FT232R, is available at <http://www.ftdichip.com>. The integrated electronics also include an RS422 transceiver plus Tx and Rx LEDs which give a visual indication of UART traffic.

The PCB is USB powered and USB 2.0 full speed compatible. Each PCB supports a data transfer rate up to 3 Mbaud and supports the FTDIChip-ID™, with a unique USB serial number programmed into the FT232R. This feature can be used to create a security or password protected file transfer access using the PCB. Further information and examples on this feature are available at <http://www.ftdichip.com> under FTDIChip-ID Projects.

The USB-RS422-PCB requires USB drivers, available free from <http://www.ftdichip.com>, which are used to make the FT232R on the PCB appear as a virtual COM port (VCP). This then allows the user to communicate with the USB interface via a standard PC serial emulation port (for example TTY). Another FTDI USB driver, the D2XX driver, can also be used with application software to directly access the FT232R on the PCB through a DLL. This is illustrated in the Figure 1.1.

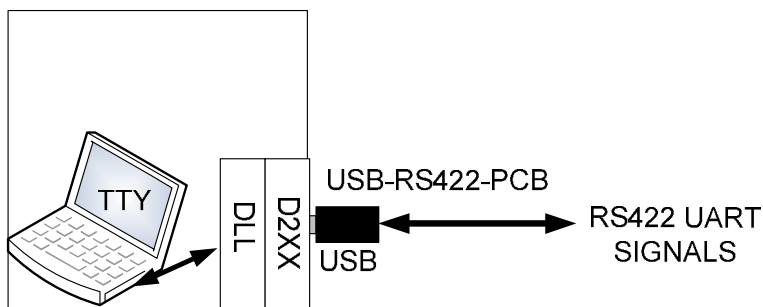
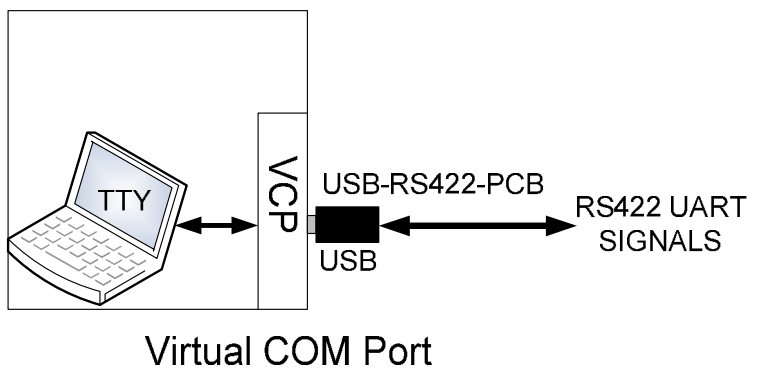

### Software application access to USB via D2XX

**Figure 1.1 Using the USB-RS422-PCB**

#### 1.1 Part Number

The following Table 1.1 gives details of the available USB-RS422-PCB.

Part Number	Description
USB-RS422-PCB	USB to RS422 level UART PCB

**Table 1.1 USB-RS422-PCB Part Number**

---

## Table of Contents

<b>1</b>	<b>Description .....</b>	<b>1</b>
1.1	Part Number.....	1
<b>2</b>	<b>Typical Applications.....</b>	<b>3</b>
2.1	Driver Support .....	3
2.2	Features.....	4
<b>3</b>	<b>Features of FT232R applicable to USB-RS422-PCB .....</b>	<b>5</b>
<b>4</b>	<b>USB-RS422-PCB Connector Pin Out and Mechanical details .....</b>	<b>6</b>
4.1	USB-RS422-PCB Signal Descriptions .....	8
4.2	USB-RS422-PCB Electrical Parameters .....	8
<b>5</b>	<b>USB-RS422-PCB Circuit Schematic .....</b>	<b>10</b>
<b>6</b>	<b>Contact Information .....</b>	<b>11</b>
	<b>Appendix A - PCB EEPROM Configuration .....</b>	<b>13</b>
	<b>Appendix B - List of Figures and Tables.....</b>	<b>14</b>
	<b>Appendix C - Revision History .....</b>	<b>15</b>

## 2 Typical Applications

- USB to Serial RS422 Level Converter.
- Upgrading Legacy Peripherals to USB.
- Interface Microcontroller UART or I/O to USB.
- Interface FPGA / PLD to USB.
- USB Instrumentation PC interface.
- USB Industrial Control.
- USB password protected file transfers.

### 2.1 Driver Support

#### **Royalty free VIRTUAL COM PORT (VCP) DRIVERS for...**

- Windows 98, 98SE, ME, 2000, Server 2003 and Server 2008
- Windows XP and XP 64-bit
- Windows Vista and Vista 64-bit
- Windows XP Embedded
- Windows CE 4.2, 5.0 and 6.0
- Mac OS 8/9, OS-X
- Linux 2.4 and greater

#### **Royalty free D2XX Direct Drivers (USB Drivers + DLL S/W Interface)**

- Windows 98, 98SE, ME, 2000, Server 2003 and Server 2008
- Windows XP and XP 64-bit
- Windows Vista and Vista 64-bit
- Windows XP Embedded
- Windows CE 4.2, 5.0 and 6.0
- Linux 2.4 and greater
- Mac OS-X

The drivers listed above are all available to download for free from **www.ftdichip.com**. Various 3rd Party Drivers are also available for various other operating systems - see **www.ftdichip.com** for details.

---

## 2.2 Features

- USB-RS422-PCB provides a USB to RS422 Serial UART interface.
- Entire USB protocol handled by the electronics on the PCB.
- EIA/TIA-422 interface with low power requirements.
- UART interface support for 7 or 8 data bits, 1 or 2 stop bits and odd / even / mark / space / no parity.
- Data transfer rates from 300 baud up to 3 Mbaud.
- Internal EEPROM with user writeable area.
- FTDI's royalty-free VCP allow for communication as a standard emulated COM port and D2XX 'direct' drivers provide DLL application programming interface.
- Support for FT232R FTDIChip-ID™ feature for improved security.
- PCB is USB Powered - no external supply required.
- Low USB bandwidth consumption.
- UHCI / OHCI / EHCI host controller compatible.
- USB 2.0 Full Speed compatible.
- -40°C to +85°C operating temperature range.
- RoHS compliant
- ESD Protection for RS-422 I/O's
  - ±15kV Human Body Model (HBM)
  - ±15kV EN61000-4-2 Air Gap Discharge
  - ±8kV EN61000-4-2 Contact Discharge

---

### 3 Features of FT232R applicable to USB-RS422-PCB

The USB-RS422-PCB uses FTDI's FT232RQ USB to serial IC device. This section summarises the key features of the FT232RQ which apply to the USB-RS422-PCB. For further details, and a full features and enhancements description consult the FT232R datasheet, this is available from [www.ftdichip.com](http://www.ftdichip.com).

**Internal EEPROM.** The internal EEPROM is used to store USB Vendor ID (VID), Product ID (PID), device serial number, product description string and various other USB configuration descriptors. Each FT232RQ is supplied with the internal EEPROM pre-programmed as described in **Appendix A - PCB EEPROM Configuration**. The internal EEPROM descriptors can be programmed in circuit, over USB without any additional voltage requirement. It can be programmed using the FTDI utility software called MPROG, which can be downloaded from FTDI Utilities on the FTDI website ([www.ftdichip.com](http://www.ftdichip.com)). Additionally, there is a user area of the internal EEPROM available to system designers to allow storing of data (note that this is not modified by MPROG).

**Lower Operating and Suspend Current.** The FT232R has a low 15mA operating supply current and a very low USB suspend current of approximately 70µA.

**Low USB Bandwidth Consumption.** The USB interface of the FT232R, and therefore the USB-RS422-PCB has been designed to use as little as possible of the total USB bandwidth available from the USB host controller.

**FTDICHIP-ID™.** The FT232R includes the new FTDICHIP-ID™ security dongle feature. This FTDICHIP-ID™ feature allows a unique number to be burnt into each FT\_232RQ during manufacture. This number cannot be reprogrammed. This number is only readable over USB can be used to form the basis of a security dongle which can be used to protect any customer application software being copied. This allows the possibility of using the USB-RS422-PCB as a dongle for software licensing. Further to this, a renewable license scheme can be implemented based on the FTDICHIP-ID™ number when encrypted with other information. This encrypted number can be stored in the user area of the FT232R internal EEPROM, and can be decrypted, then compared with the protected FTDICHIP-ID™ to verify that a license is valid. Web based applications can be used to maintain product licensing this way. An application note, AN232R-02, available from FTDI website ([www.ftdichip.com](http://www.ftdichip.com)) describes this feature.

**Extended Operating Temperature Range -** The USB-RS422-PCB is capable of operating over an extended temperature range of -40° to +85°C thus allowing it to be used in automotive or industrial applications.

#### 4 USB-RS422-PCB Connector Pin Out and Mechanical details

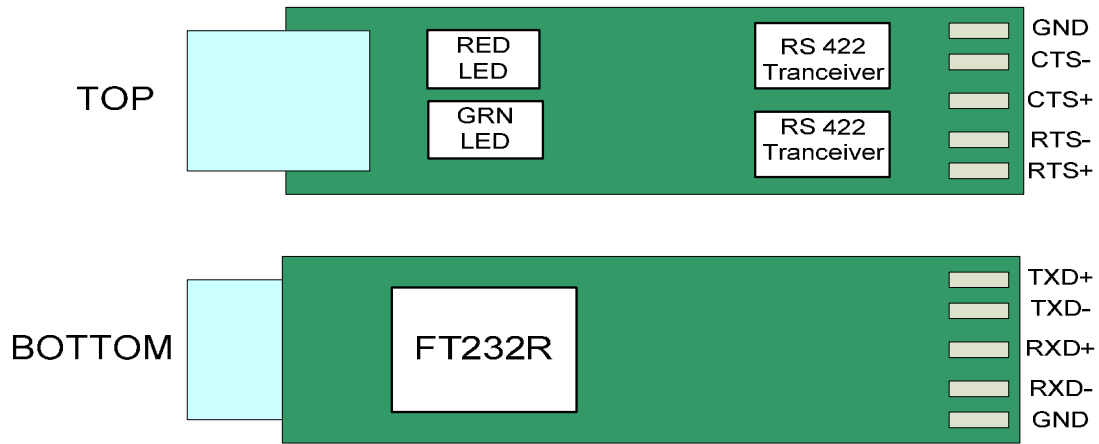

USB-RS422-PCB REV 1

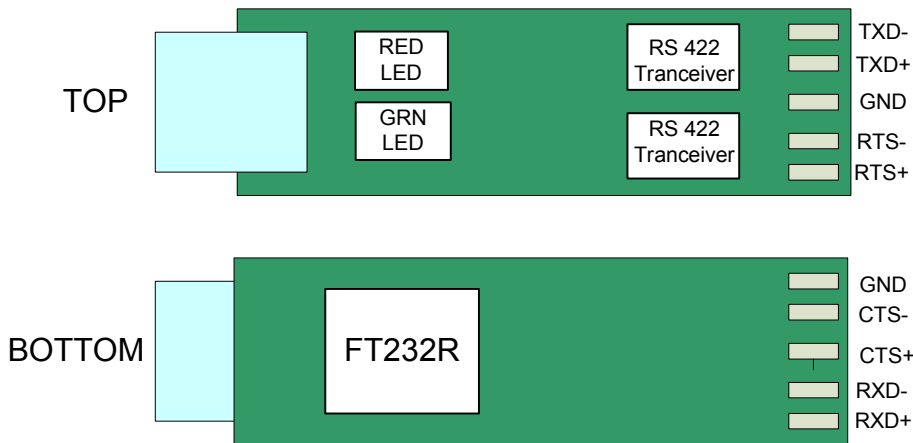

USB-RS422-PCB REV 2

**Figure 4.1 USB-RS422-PCB Pin Out (Top is TOP View, Bottom is BOTTOM View)**

The mechanical details of the PCB are shown in the following diagram Figure 4.2

The pads were re-arranged on the PCB to allow for easier wiring which resulted in a Rev 2 PCB. There were no other changes between Rev 1 and Rev 2.

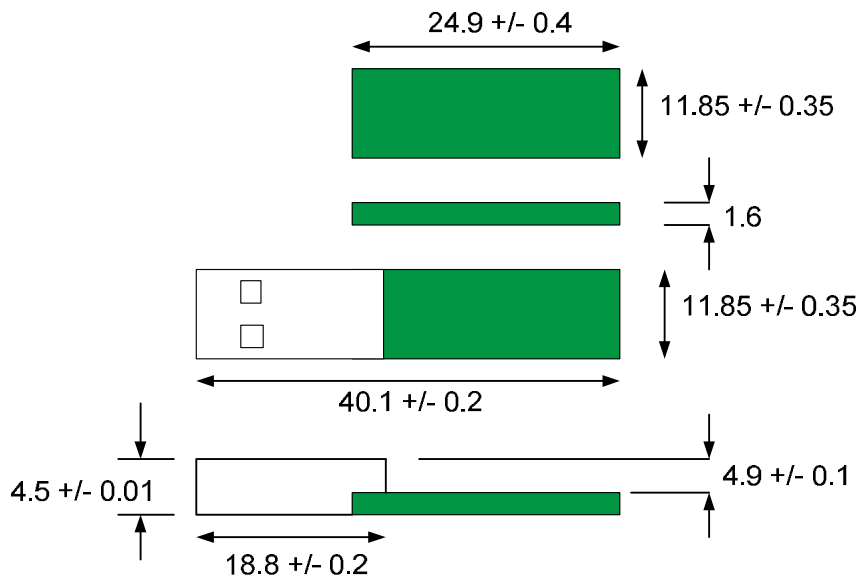

Dimensions in mm

**Figure 4.2 USB-RS422-PCB, Mechanical Details**



## 4.1 USB-RS422-PCB Signal Descriptions

Name	Type	Description
GND	GND	Device ground supply pin.
CTS+	Input	Clear to Send Control + (B), Input
TXD-	Output	Data - (A) Output
TXD+	Output	Data + (B) Output
RXD+	Input	Data + (B) Input
RTS+	Output	Request To Send Control + (B), Output
RTS-	Output	Request To Send Control - (A), Output
RXD-	Input	Data - (A) Input
CTS-	Input	Clear to Send Control input - (A), Input

**Table 4.1 USB-RS422-PCB Signal Descriptions**

## 4.2 USB-RS422-PCB Electrical Parameters

Parameter	Description	Minimum	Typical	Maximum	Units	Conditions
<b>Receiver Input</b>						
VCM	Common-mode input voltage range	-7		+12	V	
IN	Input Current			1.0	mA	VIN = +12V
				-0.8		VIN = -7V
VTH	Differential Threshold Voltage, VTH	-0.2		+0.2	V	
VIHYST	Input Hysteresis		20		mV	
RIN	Input Resistance, RIN	12	15		kΩ	
<b>Transmitter Output</b>						
VOD	Differential Output Voltage, dVOD	1.5		5	V	With RL = 54Ω. CL = 50pF *

**Table 4.2 USB-RS422-PCB I/O Characteristics**

\* - The 54 ohms is the equivalent of two 120 ohm termination resistors placed on each side of the transmission line and the input impedance of 32 receivers on the line.

Description	Conditions	Minimum	Typical	Maximum
ESD HBM	RS-422 Inputs and Outputs		±15 kV	
EN61000-4-2ContactDischarge	RS-422 Inputs and Outputs		±8 kV	
EN61000-4-2AirGapDischarge	RS-422 Inputs and Outputs		±15 kV	

**Table 4.3 USB-RS422-PCB ESD Tolerance**



---

## 6 Contact Information

### Head Office – Glasgow, UK

Future Technology Devices International Limited  
Unit 1, 2 Seaward Place, Centurion Business Park  
Glasgow G41 1HH  
United Kingdom

Tel: +44 (0) 141 429 2777  
Fax: +44 (0) 141 429 2758

E-mail (Sales) [sales1@ftdichip.com](mailto:sales1@ftdichip.com)  
E-mail (Support) [support1@ftdichip.com](mailto:support1@ftdichip.com)  
E-mail (General Enquiries) [admin1@ftdichip.com](mailto:admin1@ftdichip.com)  
Web Site URL <http://www.ftdichip.com>  
Web Shop URL <http://www.ftdichip.com>

### Branch Office – Shanghai, China

Future Technology Devices International Limited (China)  
Room 408, 317 Xianxia Road,  
ChangNing District,  
ShangHai, China

Tel: +86 (21) 62351596  
Fax: +86(21) 62351595

E-Mail (Sales): [cn.sales@ftdichip.com](mailto:cn.sales@ftdichip.com)  
E-Mail (Support): [cn.support@ftdichip.com](mailto:cn.support@ftdichip.com)  
E-Mail (General Enquiries): [cn.admin1@ftdichip.com](mailto:cn.admin1@ftdichip.com)  
Web Site URL: <http://www.ftdichip.com>

### Branch Office – Taipei, Taiwan

Future Technology Devices International Limited (Taiwan)  
2F, No. 516, Sec. 1, NeiHu Road  
Taipei 114  
Taiwan , R.O.C.  
Tel: +886 (0) 2 8797 1330  
Fax: +886 (0) 2 8751 9737

E-mail (Sales) [tw.sales1@ftdichip.com](mailto:tw.sales1@ftdichip.com)  
E-mail (Support) [tw.support1@ftdichip.com](mailto:tw.support1@ftdichip.com)  
E-mail (General Enquiries) [tw.admin1@ftdichip.com](mailto:tw.admin1@ftdichip.com)  
Web Site URL <http://www.ftdichip.com>

### Branch Office – Hillsboro, Oregon, USA

Future Technology Devices International Limited (USA)  
7235 NW Evergreen Parkway, Suite 600  
Hillsboro, OR 97123-5803  
USA  
Tel: +1 (503) 547 0988  
Fax: +1 (503) 547 0987

E-Mail (Sales) [us.sales@ftdichip.com](mailto:us.sales@ftdichip.com)  
E-Mail (Support) [us.admin@ftdichip.com](mailto:us.admin@ftdichip.com)  
Web Site URL <http://www.ftdichip.com>

**Distributor and Sales Representatives**

Please visit the Sales Network page of the FTDI Web site for the contact details of our distributor(s) and sales representative(s) in your country.

## Appendix A - PCB EEPROM Configuration

Each USB-RS422-PCB is controlled by the FTDI FT232R IC. This FT232R device contains an EEPROM which contains the USB configuration descriptors for that device. When the PCB is plugged into a PC or a USB reset is performed, the PC will read these descriptors. The default values stored into the internal EEPROM are defined in Table 0.1 Default Internal EEPROM Configuration

Parameter	Value	Notes
USB Vendor ID (VID)	0403h	FTDI default VID (hex)
USB Product UD (PID)	6001h	FTDI default PID (hex)
Serial Number Enabled?	Yes	
Serial Number	See Note	A unique serial number is generated and programmed into the EEPROM during device final test.
Pull down I/O Pins in USB Suspend	Disabled	Enabling this option will make the device pull down on the UART interface lines when the power is shut off (PWREN# is high).
Manufacturer Name	FTDI	
Product Description	See note	USB-RS422-PCB
Max Bus Power Current	90mA	
Power Source	Bus Powered	
Device Type	FT232R	
USB Version	0200	Returns USB 2.0 device description to the host. Note: The device is be a USB 2.0 Full Speed device (12Mb/s) as opposed to a USB 2.0 High Speed device (480Mb/s).
Remote Wake Up	Disabled	
High Current I/Os	Enabled	Enables the high drive level on the UART and CBUS I/O pins.
Load VCP Driver	Enabled	Makes the device load the VCP driver interface for the device.
Invert TXD	Disabled	Signal on this pin becomes TXD# if enable.
Invert RXD	Disabled	Signal on this pin becomes RXD# if enable.
Invert RTS#	Disabled	Signal on this pin becomes RTS if enable.
Invert CTS#	Disabled	Signal on this pin becomes CTS if enable.

**Table 0.1 Default Internal EEPROM Configuration**

The internal EEPROM on the PCB can be re-programmed over USB using the utility program MPROG. MPROG can be downloaded from the [www.ftdichip.com](http://www.ftdichip.com). Version 2.8a or later is required for the FT232R chip. Users who do not have their own USB Vendor ID but who would like to use a unique Product ID in their design can apply to FTDI for a free block of unique PIDs. Contact FTDI support for this service.

---

## Appendix B - List of Figures and Tables

### List of Figures

Figure 1.1 Using the USB-RS422-PCB.....	1
Figure 4.1 USB-RS422-PCB Pin Out (Top is TOP View, Bottom is BOTTOM View).....	6
Figure 4.2 USB-RS422-PCB, Mechanical Details.....	7
Figure 5.1 Circuit Schematic of USB-RS422-PCB. ....	10

### List of Tables

Table 1.1 USB-RS422-PCB Part Number .....	1
Table 4.1 USB-RS422-PCB Signal Descriptions .....	8
Table 4.2 USB-RS422-PCB I/O Characteristics.....	8
Table 4.3 USB-RS422-PCB ESD Tolerance .....	9
Table 0.1 Default Internal EEPROM Configuration.....	13

## Appendix C - Revision History

Version Draft	First Draft	January 2009
Version 1.0	First Release	21 <sup>st</sup> January 2009
Version 1.01	Corrected the PCB drawing and TW address	09 <sup>th</sup> February 2009
Version 1.02	Added rev1 and rev2 PCB drawings	13 <sup>th</sup> April 2009