

LE-50W-01-EVAL

Evaluation Kit

Perfect for Crystal IS UVC LED evaluation and germicidal testing and verification.



UVC Evaluation KIT Includes:

- 80mW UVC LED
- Heatsink
- LEDiL Violetta (2x)
- Driver and Power Cord

[Click for product info](#)

UV Type	Wavelength (nm)	#LEDs	Forward Current (mA)	Rad. Power (mW)	Forward Voltage (V)	Power (W)	Ts (°C)	EFF (%)
UVC	260-270nm	1	300	56.0	7.5	2.6	40	2.0
			500	70.0	8.0	4.0	40	1.8
			600	74.0	9.0	5.4	40	1.4

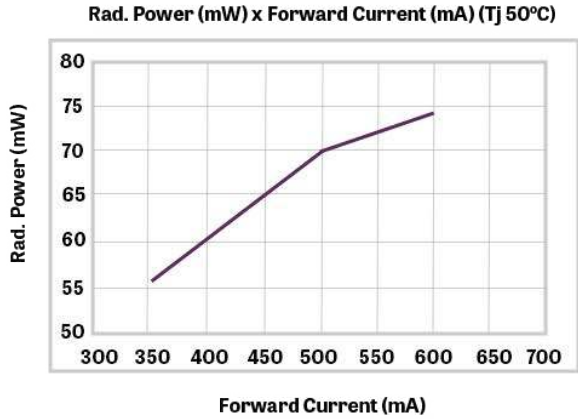
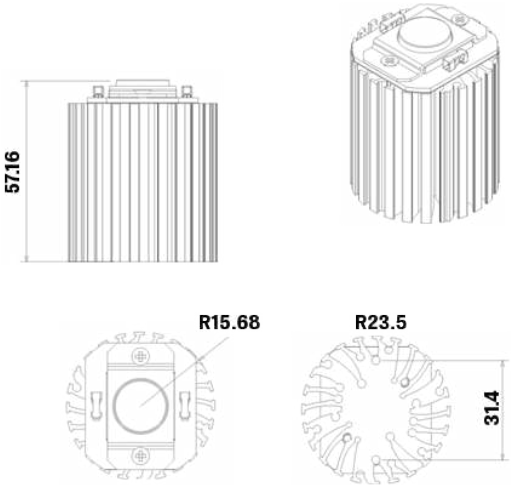

Manufacturer	Part Number	Color	Beam
LEDiL	FN17822_VIOLETTA-S	Clear	~15°
LEDiL	FN17826_VIOLETTA-W	Clear	~60°

