



SPX1585

5A Low Dropout Voltage Regulator Adjustable & Fixed Output, Fast Response

FEATURES

- Adjustable Output Down To 1.2V
- Fixed Output Voltages 1.5V, 2.5V, 3.3V
- Output Current Of 5A
- Low Dropout Voltage 1.1V Typ @ 5A.
- Extremely Tight Load And Line Regulation
- Current & Thermal Limiting
- Standard 3-Terminal Low Cost TO-220 & TO-263
- Similar To Industry Standard LT1085/LT1585

APPLICATIONS

- Powering VGA & Sound Card
- Power PC™ Supplies
- SMPS Post-Regulator
- High Efficiency “Green” Computer Systems
- High Efficiency Linear Power Supplies
- Portable Instrumentation
- Constant Current Regulators
- Adjustable Power Supplies
- Battery charger

Now Available in Lead Free Packaging

PRODUCT DESCRIPTION

The SPX1585 is a low power 5A adjustable and fixed voltage regulator that is very easy to use. It requires only 2 external resistors to set the output voltage for the adjustable version. The SPX1585 devices are designed for low voltage applications that offer lower dropout voltage and faster transient response. This device is an excellent choice for use in powering low voltage microprocessors that require a lower dropout, faster transient response to regulate from +2.5V to 3.8V supplies, and as a post regulator for switching supplies applications. The SPX1585 features low dropout of a maximum 1.2 volts.

The SPX1585 offers full protection against over-current faults, reversed input polarity, reversed load insertion, and positive and negative transient voltage. On-Chip trimming adjusts the reference voltage to 1%. The I_Q of this device flows into the load, which increases efficiency.

The SPX1585 devices are offered in a 3-pin TO-220 and TO-263 package compatible with other 3 terminal regulators. For an 8A low dropout regulator, refer to the SPX158 data sheet.

PIN CONNECTIONS

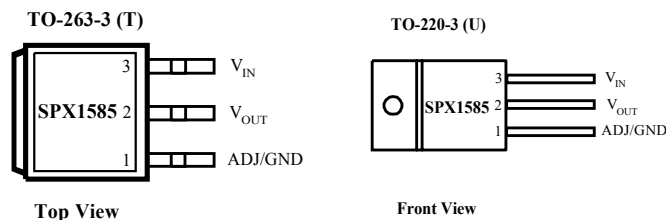

Note that TAB is connected to VOUT for both package types.

ABSOLUTE MAXIMUM RATINGS

Lead Temp. (Soldering, 10 Seconds)	300°C
Storage Temperature Range	-65° to +150°C
Operating Junction Temperature Range	
SPX1585 Control Section.....	-45°C +125°C
SPX1585 Power Transistor.....	-45°C +150°C

Input Voltage.....	10V
Input to Output Voltage Differential	10V

ELECTRICAL CHARACTERISTICS (NOTE 1) at I_{OUT} = 10mA, T_A=25°C, unless otherwise specified.

PARAMETER	CONDITIONS	Typ	SPX1585A		SPX1585		UNITS
			Min	Max	Min	Max	
1.5V Version							
Output Voltage (Note 2)	SPX1585-1.5V, 0 < I _{OUT} < 5A, 3.3V < V _{IN} < 10V	1.5	1.485	1.515	1.47	1.53	V
			1.47	1.53	1.455	1.545	
2.5V Version							
Output Voltage (Note 2)	SPX1585-2.5V, 0 < I _{OUT} < 5A, 4.0V < V _{IN} < 10V	2.5	2.475	2.525	2.45	2.55	V
			2.45	2.55	2.425	2.575	
3.3V Version							
Output Voltage (Note 2)	SPX1585-3.3V, 0 < I _{OUT} < 5A, 4.8V < V _{IN} < 10V	3.3	3.267	3.333	3.234	3.366	V
			3.234	3.366	3.069	3.399	
All Voltage Options							
Reference Voltage (V _{ref})	V _{IN} ≤ 7V, P ≤ P _{MAX} 1.5V ≤ (V _{IN} - V _{OUT}) ≤ 5.75V, 10mA ≤ I _{OUT} ≤ 5A	1.250	1.225	1.270	1.225	1.270	V
Min. Load Current (Note 3)	1.5V ≤ (V _{IN} - V _{OUT}) ≤ 5.75V	5		10		10	V
Line Regulation (ΔV _{ref} (V _{in}))	2.75V ≤ V _{IN} ≤ 7V, I _{out} = 10mA, T _J = 25°C (Note 3)	0.005		0.2		0.2	%
	V _{IN} ≤ 7V, I _{OUT} = 0mA, T _J = 25°C (Note 2)	0.005		0.2		0.2	
Load Regulation (ΔV _{ref} (I _{out}))	10mA ≤ I _{OUT} ≤ 5A, (V _{IN} - V _{OUT}) = 3V, T _J = 25°C (Note 3)	0.05		0.3		0.3	%
	0 ≤ I _{OUT} ≤ 5A, V _{IN} = 7V, T _J = 25°C (Note 2)	0.05		0.3		0.3	
Dropout Voltage	ΔV _{REF} = 1% I _{OUT} = 5A (Note 3) I _{OUT} < 5A (Note 2)	1.1		1.2		1.2	
Current Limit I _{out} (MAX)	V _{IN} = 7V	6	5.2		5.2		A
	1.4V ≤ (V _{IN} - V _{OUT}) (Note 3)						
Long Term Stability	T _A = 125°C, 1000 Hrs.	0.3 (Note 2)		1		1	%
Thermal Regulation (ΔV _{out} (P _{wr}))	T _A = 25°C, 20 ms pulse	0.01		0.020		0.020	%/W
Temperature Stability (ΔV _{out} (T))		0.25					%
Output Noise, RMS	10Hz to 10kHz T _A = 25°C	0.003					% V _O
Thermal Resistance	TO-220	Junction to Tab		3.0		3.0	°C/W
		Junction to Ambient		60		60	
	DD Package	Junction to Tab		3.0		3.0	
		Junction to Ambient		60		60	

The Bold specifications apply to the full operating temperature range.

Note 1: Changes in output voltage due to heating effects are covered under the specification for thermal regulation.

Note 2: Fixed Version Only

Note 3: Adjustable Version Only

APPLICATION HINTS

The SPX1585 incorporates protection against over-current faults, reversed load insertion, over temperature operation, and positive and negative transient voltages. However, the use of an output capacitor is required in order to insure the stability and the performance of the device.

Stability

The output capacitor is part of the regulator's frequency compensation system. Either a 22 μ F aluminum electrolytic capacitor or a 10 μ F solid tantalum capacitor between the output terminal and ground guarantees stable operation for all operating conditions. The recommended value for ESR is 0.5Ohms or less.

However, in order to minimize overshoot and undershoot, and therefore optimize the design, please refer to the section 'Ripple Rejection'.

Ripple Rejection

Ripple rejection can be improved by adding a capacitor between the ADJ pin and ground. When ADJ pin bypassing is used, the value of the output capacitor required increases to its maximum (220 μ F for an aluminum electrolytic capacitor, or 47 μ F for a solid tantalum capacitor). If the ADJ pin is not bypassed, the value of the output capacitor can be lowered to 10 μ F for an electrolytic aluminum capacitor or 4.7 μ F for a solid tantalum capacitor.

However the value of the ADJ-bypass capacitor should be chosen with respect to the following equation:

$$C = 1 / (6.28 * F_R * R_1)$$

Where C = value of the capacitor in Farads
(select an equal or larger standard value),
F_R = ripple frequency in Hz,
R₁ = value of resistor R₁ in Ohms.

If an ADJ-bypass capacitor is used, the amplitude of the output ripple will be independent of the output voltage. If an ADJ-bypass capacitor is not used, the output ripple will be proportional to the ratio of the output voltage to the reference voltage:

$$M = V_{OUT} / V_{REF}$$

Where M = multiplier for the ripple seen when the ADJ pin is optimally bypassed.

V_{REF} = Reference Voltage

Reducing parasitic resistance and inductance

One solution to minimize parasitic resistance and inductance is to connect in parallel capacitors. This arrangement will improve the transient response of the power supply if your system requires rapidly changing current load condition.

Thermal Consideration

Although the SPX1585 offers some limiting circuitry for overload conditions, it is necessary not to exceed the maximum junction temperature, and therefore to be careful about thermal resistance. The heat flow will follow the lowest resistance path, which is the Junction-to-case thermal resistance. In order to insure the best thermal flow of the component, a proper mounting is required. Note that the case of the device is electrically connected to the output. If the case must be electrically isolated, a thermally conductive spacer can be used. However do not forget to consider its contribution to thermal resistance.

Assuming:

$$V_{IN} = 10V, V_{OUT} = 5V, I_{OUT} = 1.5A, T_A = 50^{\circ}C/W,$$

$$\theta_{Heatsink Case} = 6^{\circ}C/W, \theta_{Heatsink Case} = 0.5^{\circ}C/W, \theta_{JC} = 3^{\circ}C/W$$

Power dissipation under this condition

$$P_D = (V_{IN} - V_{OUT}) * I_{OUT} = 7.5W$$

Junction Temperature

$$T_J = T_A + P_D * (\theta_{Case-HS} + \theta_{HS} \theta_{JC})$$

For the Control Section

$$T_J = 50 + 7.5*(0.5 + 6=3) = 121.25^{\circ}C$$

121.25 $^{\circ}$ C < T_{J(max)} for the Control & Power Sections.

In both conditions, reliable operation is insured by adequate junction temperature.

Basic Adjustable Regulator

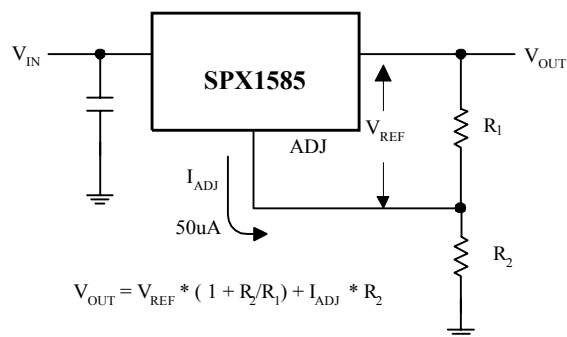

Fig.2 Basic Adjustable Regulator

Output Voltage

Consider Figure 2. The resistance R_1 generates a constant current flow, normally the specified load current of 10mA. This current will go through the resistance R_2 to set the overall output voltage. The current I_{ADJ} is very small and constant. Therefore its contribution to the overall output voltage is very small and can generally be ignored.

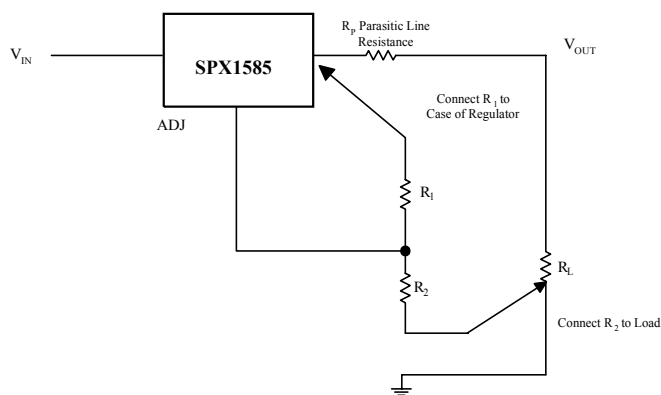
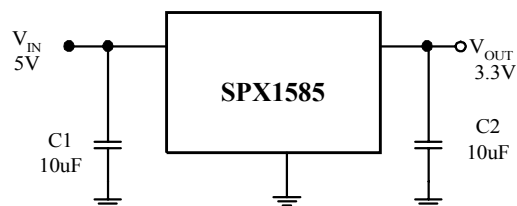

Fig.3 Basic Adjustable Regulator

Load Regulation

Parasitic line resistance can degrade load regulation. In order not to affect the behavior of the regulator, it is best to connect directly the R_1 resistance from the resistor divider to the case, and not to the load. For the same reason, it is best to connect the resistor R_2 to the Negative side of the load.



Basic Fixed Regulator

Output Voltage

The fixed voltage LDO voltage regulators are simple to use regulators since the V_{OUT} is preset to the specifications. It is important, however, to provide the proper output capacitance for stability and improvement. For most operating conditions a capacitance of 22uF tantalum or 100uF electrolytic will ensure stability and prevent oscillation.

TYPICAL APPLICATIONS

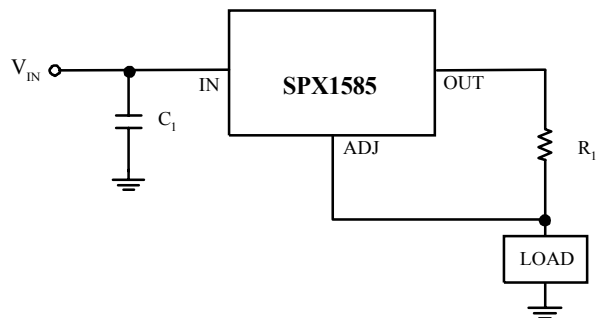
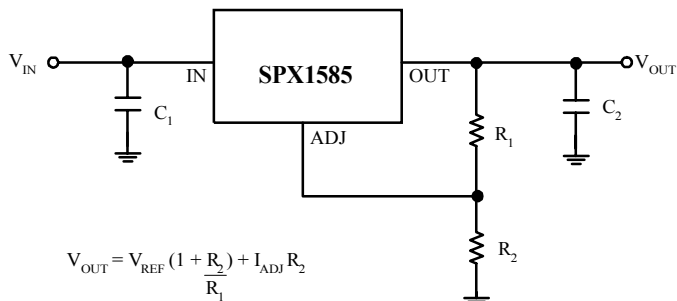

Fig. 4 5A Current output Regulator



$$V_{OUT} = V_{REF} \left(1 + \frac{R_2}{R_1}\right) + I_{ADJ} R_2$$

Fig. 5 Typical Adjustable Regulator

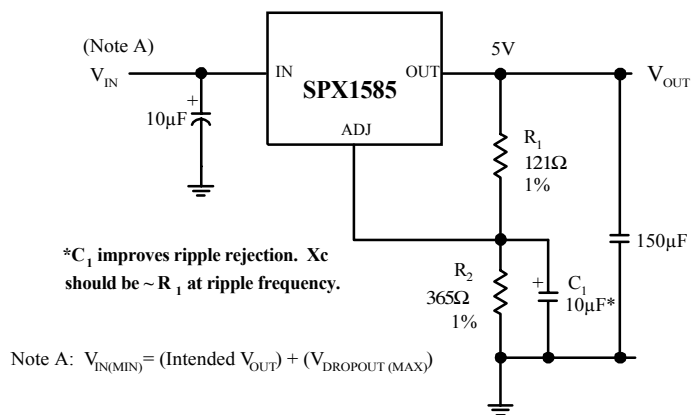

Fig. 6 Improving Ripple Rejection

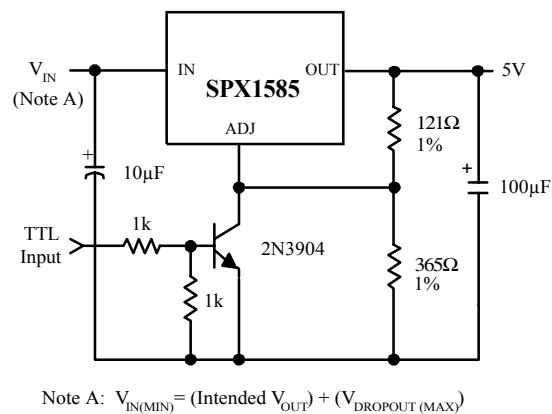
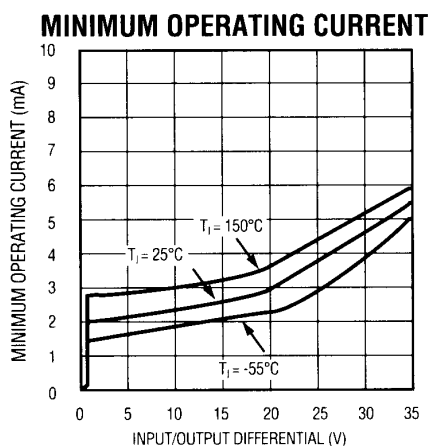
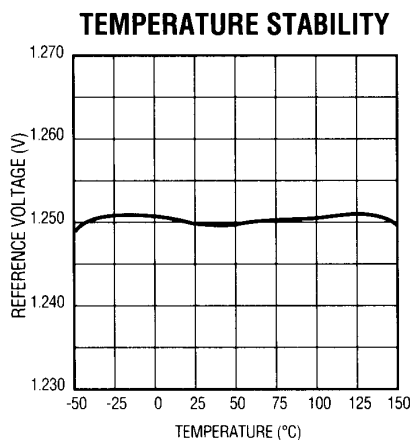
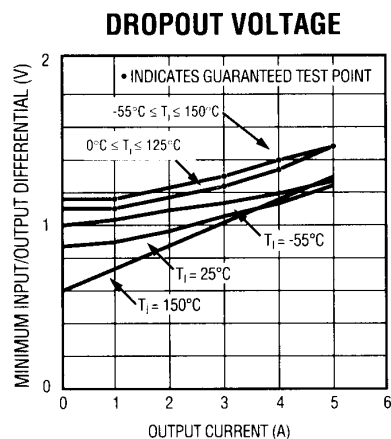
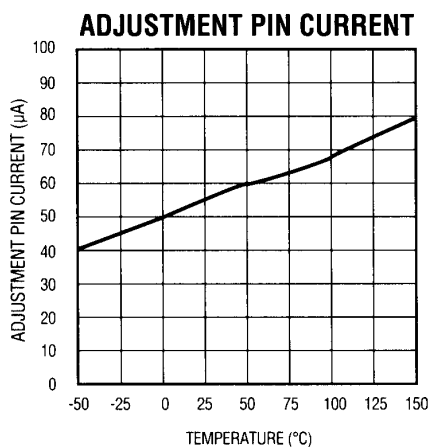
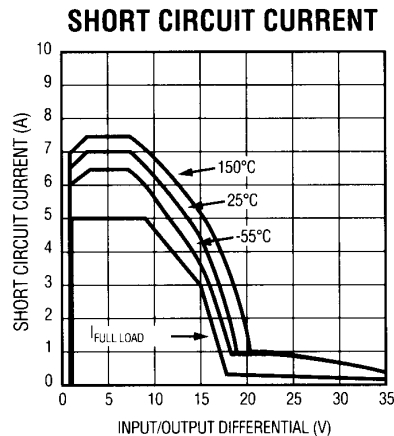
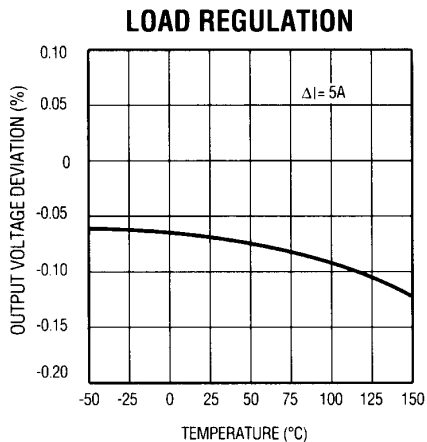

Fig.7 5V Regulator with Shutdown

TYPICAL CHARACTERISTICS

TYPICAL PERFORMANCE CHARACTERISTICS



ORDERING INFORMATION

Ordering No.	Precision	Output Voltage	Packages
SPX1585U	2%	Adj	3 Lead TO-220
SPX1585U-1.5	2%	1.5V	3 Lead TO-220
SPX1585U-2.5	2%	2.5V	3 Lead TO-220
SPX1585U-3.3	2%	3.3V	3 Lead TO-220
SPX1585AU	1%	Adj	3 Lead TO-220
SPX1585AU-1.5	1%	1.5V	3 Lead TO-220
SPX1585AU-2.5	1%	2.5V	3 Lead TO-220
SPX1585AU-3.3	1%	3.3V	3 Lead TO-220
SPX1585T	2%	Adj	3 Lead TO-263
SPX1585T-1.5	2%	1.5V	3 Lead TO-263
SPX1585T-2.5	2%	2.5V	3 Lead TO-263
SPX1585T-3.3	2%	3.3V	3 Lead TO-263
SPX1585AT	1%	Adj	3 Lead TO-263
SPX1585AT-1.5	1%	1.5V	3 Lead TO-263
SPX1585AT-2.5	1%	2.5V	3 Lead TO-263
SPX1585AT-3.3	1%	3.3V	3 Lead TO-263

Available in Lead free packaging.
To order add "-L" suffix to the part number.
EXAMPLE: SPX1585U /ER = standard,
SPX1585U /ER-L = lead free.



SIGNAL PROCESSING EXCELLENCE

Sipex Corporation

Headquarters and Main Offices:
22 Linnell Circle
Billerica, MA 01821
TEL: (978) 667-8700
FAX: (978) 670-9001
e-mail: sales@sipex.com

233 South Hillview Drive
Milpitas, CA 95035
TEL: (408) 935-7600
FAX: (408) 934-7500

Sipex Corporation reserves the right to make changes to any products described herein. Sipex does not assume any liability arising out of the application or use of any product or circuit described herein; neither does it convey any license under its patent rights nor the rights of others.

Date: 05/14/04