

- 1 POSITION TOLERANCE APPLIES AT CONTACT TIP.
- 2 POSITION NUMBERS SHOWN FOR REFERENCE ONLY.
- 3 MATERIAL:
HOUSING - POLYPHTHALAMIDE, BLACK, UL 94-VO RATED.
SHELL - CARBON STEEL PER ASTM A109.
CONTACTS - PHOSPHOR BRONZE PER QQ-B-750.
BRACKETS - ZINC
- 4 FINISH:
SHELL - 5.08µm [.000200] MIN NICKEL OVER 1.27µm [.000050] MIN COPPER.
BRACKET - 3.81µm [.000150] MIN NICKEL OVER 5.08µm [.000200] MIN COPPER.
CONTACTS - EITHER 0.76µm [.000030] MIN GOLD PLATE OR GOLD FLASH OVER PALLADIUM NICKEL PLATE, 0.76µm [.000030] MIN TOTAL, FOR A LENGTH OF 0.64 [.025] MIN, 0.13 [.005] MAX FROM MATING END, 1.27µm [.000050] MIN TIN-LEAD ON OPPOSITE END FOR A LENGTH OF 4.78 [.188] MIN, ALL OVER 1.27µm [.000050] MIN NICKEL UNDERPLATE.
- 5 PC BOARD HOLE RECOMMENDATIONS:
A. HOLES SHOULD BE DRILLED WITH A 0.701 [.0276] DRILL.
B. PC BOARD PLATING TO BE 7.62µm [.000300] MIN TIN-LEAD OVER 0.025-0.038 [.0010-.0015] COPPER.
C. RECOMMENDED HOLE SIZE AFTER TIN-LEAD PLATING IS 0.56-0.66 [.022-.026].

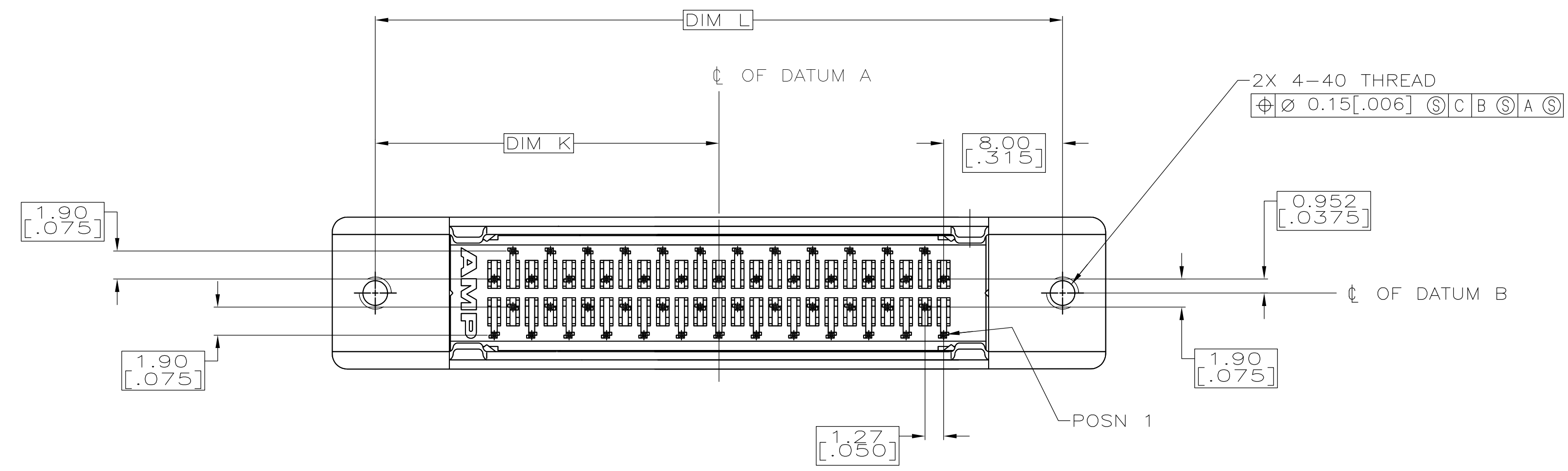

PER DETAIL Y	52.45 [2.065]	30.48 [1.200]	34.70 [1.366]	42.29 [1.665]	46.48 [1.830]	23.24 [.915]	50	1761055-1
RECOMMENDED PCB MTG DIMENSIONS	R	P	N	M	L	K	NO OF POSN	PART NUMBER

THIS DRAWING IS A CONTROLLED DOCUMENT.

DWNS: B. MCMASTER 25FEB04	Tyco Electronics Corporation Harrisburg, PA 17105-3608
CHK: J. GERACE 25FEB04	
APRD: M. WALMSLEY 25FEB04	NAME: RECEPTACLE ASSEMBLY, SHIELDED, VERTICAL, RAILED, ACTION PIN, 108-1228
TOLERANCES UNLESS OTHERWISE SPECIFIED:	PRODUCT SPEC: 108-1228
0 PLC ± -	APPLICATION SPEC: 114-40029
1 PLC ± -	SIZE: A1
2 PLC ± 0.13 [.005]	CAGE CODE: 00779
3 PLC ± -	DRAWING NO: 1761055
4 PLC ± -	RESTRICTED TO: -
ANGLES ± -	WEIGHT: -
FINISH 4	CUSTOMER DRAWING

SCALE: 4:1 SHEET 1 OF 1 REV B