

FEATURES

- 12-bit temperature-to-digital converter
- ±2°C accuracy
- Operation from –20°C to +125°C
- Operation from 3 V to 3.6 V
- 240 µA typical average supply current
- Selectable 1.5°C, 3°C, 6°C hysteresis
- SMBus-/I²C®-compatible interface
- Dual-purpose event pin: comparator or interrupt
- 8-lead LFCSP, 3 mm × 3 mm (JEDEC MO-229 WEED-4) package
- Complies with JEDEC standard JC-42.4 memory module
- Thermal sensor component specification

APPLICATIONS

- Memory module temperature monitoring
- Isolated sensors
- Environmental control systems
- Computer thermal monitoring
- Thermal protection
- Industrial process control
- Power system monitors

GENERAL DESCRIPTION

The [ADT7408](#) is the first digital temperature sensor that complies with JEDEC standard JC-42.4 for the mobile platform memory module. The [ADT7408](#) contains a band gap temperature sensor and a 12-bit ADC to monitor and digitize the temperature to a resolution of 0.0625°C.

There is an open-drain EVENT# output that is active when the monitoring temperature exceeds a critical programmable limit or when the temperature falls above or below an alarm window. This pin can operate in either comparator or interrupt mode. There are three slave device address pins that allow up to eight [ADT7408s](#) to be used in a system that monitors temperature of various components and subsystems.

FUNCTIONAL BLOCK DIAGRAM

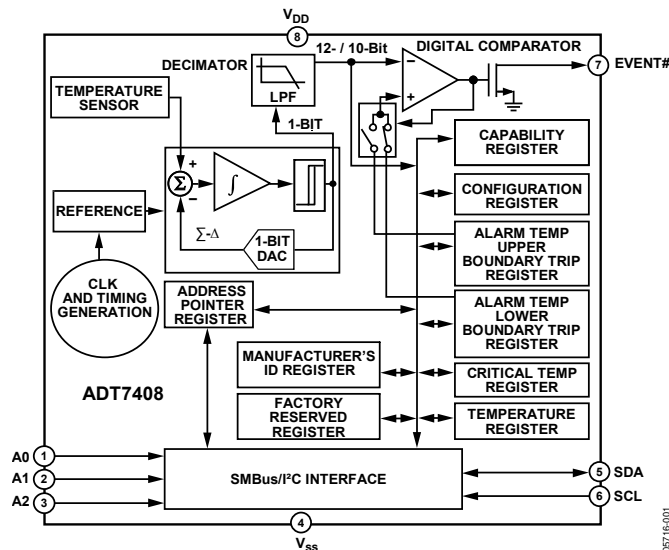

Figure 1.

The [ADT7408](#) is specified for operation at supply voltages from 3.0 V to 3.6 V. Operating at 3.3 V, the average supply current is less than 240 µA typical. The [ADT7408](#) offers a shutdown mode that powers down the device and gives a shutdown current of 3 µA typical. The [ADT7408](#) is rated for operation over the –20°C to +125°C temperature range. The [ADT7408](#) is available in a lead-free, 8-lead LFCSP, 3 mm × 3 mm (JEDEC MO-229 WEED-4) package.

TABLE OF CONTENTS

Features	1	Address Pointer Register (Write Only).....	10
Applications.....	1	Capability Register (Read Only)	10
Functional Block Diagram	1	Configuration Register (Read/Write)	11
General Description	1	Temperature Trip Point Registers	13
Revision History	2	ID Registers	14
Specifications.....	3	Temperature Data Format.....	15
Timing Characteristics	4	Event Pin Functionality	16
Timing Diagram	4	Serial Interface	17
Absolute Maximum Ratings.....	5	SMBus/I ² C Communications	18
ESD Caution.....	5	Applications information	21
Pin Configuration and Function Descriptions.....	6	Thermal Response Time	21
Typical Performance Characteristics	7	Self-Heating Effects.....	21
Theory of Operation	8	Supply Decoupling	21
Circuit Information.....	8	Temperature Monitoring.....	21
Converter Details.....	8	Outline Dimensions	22
Modes of Operation	8	Ordering Guide	22
Registers	10		

REVISION HISTORY

6/2016—Rev. 0 to Rev. A

Changed CP-8-2 to CP-8-13	Throughout
Changes to Figure 4.....	6
Updated Outline Dimensions	22
Changes to Ordering Guide	22

3/2006—Revision 0: Initial Version

SPECIFICATIONS

All specifications $T_A = -20^{\circ}\text{C}$ to $+125^{\circ}\text{C}$, $V_{DD} = 3.0\text{ V}$ to 3.6 V , unless otherwise noted.

Table 1.

Parameter	Symbol	Min	Typ	Max	Unit	Test Conditions/Comments
TEMPERATURE SENSOR AND ADC						
Local Sensor Accuracy (C Grade)			± 0.5	± 2.0	$^{\circ}\text{C}$	$75^{\circ}\text{C} \leq T_A \leq 95^{\circ}\text{C}$, $3.0\text{ V} \leq V_{DD} \leq 3.6\text{ V}$ active range
			± 1	± 3.0	$^{\circ}\text{C}$	$40^{\circ}\text{C} \leq T_A \leq 125^{\circ}\text{C}$, $3.0\text{ V} \leq V_{DD} \leq 3.6\text{ V}$ monitor range
			± 1	± 4.0	$^{\circ}\text{C}$	$-20^{\circ}\text{C} \leq T_A \leq 125^{\circ}\text{C}$, $3.0\text{ V} \leq V_{DD} \leq 3.6\text{ V}$
ADC Resolution			12		Bits	
Temperature Resolution			0.0625		$^{\circ}\text{C}$	
Temperature Conversion Time			60	125	ms	
Long Term Drift			0.081		$^{\circ}\text{C}$	Drift over 10 years, if part is operated at 55°C
EVENT# OUTPUT (OPEN DRAIN)						
Output Low Voltage, V_{OL}				0.4	V	$I_{OL} = 3\text{ mA}$
Pin Capacitance			10		pF	
High Output Leakage Current	I_{OH}		0.1	1	μA	EVENT# = 3.6 V
Rise Time ¹	t_{LH}		30		ns	
Fall Time ¹	t_{HL}		30		ns	
R_{ON} Resistance (Low Output) ¹			15		Ω	Supply and temperature dependent
DIGITAL INPUTS						
Input Current	I_{IH}, I_{IL}	-1		+1	μA	$V_{IN} = 0\text{ V}$ to V_{DD}
Input Low Voltage	V_{IL}			0.8	V	$3.0\text{ V} \leq V_{DD} \leq 3.6\text{ V}$
Input High Voltage	V_{IH}	2.1			V	$3.0\text{ V} \leq V_{DD} \leq 3.6\text{ V}$
SCL, SDA Glitch Rejection ¹				50	ns	Input filtering suppresses noise spikes of less than 50 ns
Pin Capacitance ¹				10	pF	
DIGITAL OUTPUT (OPEN DRAIN)						
Output Low Current	I_{OL}	6			mA	SDA forced to 0.6 V
Output Low Voltage	V_{OL}			0.4	V	$3.0\text{ V} \leq V_{DD} \leq 3.6\text{ V}$ at $I_{OPULL_UP} = 350\text{ }\mu\text{A}$
Output High Voltage	V_{OH}	2.1			V	
Output Capacitance ¹	C_{OUT}			10	pF	
POWER REQUIREMENTS						
Supply Voltage	V_{DD}	3.0	3.3	3.6	V	
Average Supply Current	I_{DD}		240	500	μA	
Supply Current	I_{DD_CONV}		360	550	μA	Device current while converting
Shutdown Mode at 3.3 V			3	20	μA	
Average Power Dissipation	P_D		790		μW	$V_{DD} = 3.3\text{ V}$, normal mode at 25°C

¹ Guaranteed by design and characterization, not production tested.

TIMING CHARACTERISTICS

T_A = -20°C to +125°C, V_{DD} = 3.0 V to 3.6 V, unless otherwise noted.

Table 2.

Parameter ¹	Symbol	Min	Typ	Max	Unit	Test Conditions/Comments
SCL Clock Frequency	f _{SCL}	10		100	kHz	
Bus Free Time Between a Stop (P) and Start (S) Condition	t _{BUF}	4.7			μs	
Hold Time After (Repeated) Start Condition	t _{HD:STA}	4.0			μs	After this period, the first clock is generated.
Repeated Start Condition Setup Time	t _{SU:STA}	4.7			μs	
High Period of the SCL Clock	t _{HIGH}	4.0	50		μs	
Low Period of the SCL Clock	t _{LOW}	4.7			μs	
Fall Time of Both SDA and SCL Signals	t _F			300	ns	
Rise Time of Both SDA and SCL Signals	t _R			1000	ns	
Data Setup Time	t _{SU:DAT}	250			ns	
Data Hold Time	t _{HD:DAT}	300			ns	
Setup Time for Stop Condition	t _{SU:STO}	4.0			μs	
Capacitive Load for Each Bus Line, C _B				400	pF	

¹ Guaranteed by design and characterization, not production tested.

TIMING DIAGRAM

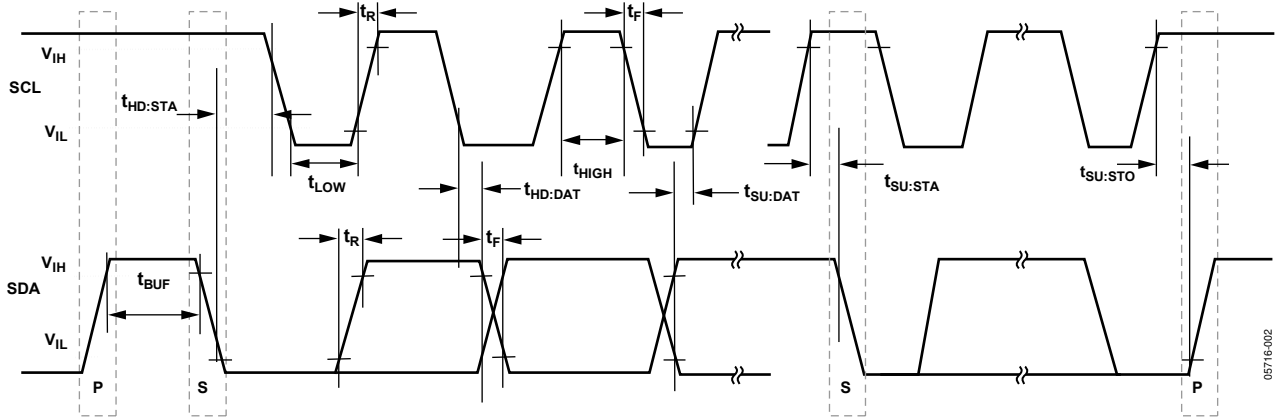

Figure 2. SMBus/I²C Timing Diagram

05716-002

ABSOLUTE MAXIMUM RATINGS

Table 3.

Parameter	Rating
V _{DD} to V _{SS}	-0.3 V to +7 V
SDA Input Voltage to V _{SS}	-0.3 V to V _{DD} + 0.3 V
SDA Output Voltage to V _{SS}	-0.3 V to V _{DD} + 0.3 V
SCL Input Voltage to V _{SS}	-0.3 V to V _{DD} + 0.3 V
EVENT# Output Voltage to V _{SS}	-0.3 V to V _{DD} + 0.3 V
Operating Temperature Range	-55°C to +150°C
Storage Temperature Range	-65°C to +160°C
Maximum Junction Temperature, T _{JMAX}	150°C
Thermal Resistance ¹	
θ _{JA} , Junction-to-Ambient (Still Air)	85°C/W
IR Reflow Soldering Profile	Refer to Figure 3

¹ Power Dissipation P_{MAX} = (T_{JMAX} - T_A)/θ_{JA}, where T_A is the ambient temperature. Thermal resistance value relates to the package being used on a standard 2-layer PCB, which gives a worst-case θ_{JA}. Some documents may publish junction to case, thermal resistance θ_{JC}, but it refers to a component that is mounted on an ideal heat sink. As a result, junction to ambient, thermal resistance is more practical for air cooled, PCB mounted components.

Stresses at or above those listed under Absolute Maximum Ratings may cause permanent damage to the product. This is a stress rating only; functional operation of the product at these or any other conditions above those indicated in the operational section of this specification is not implied. Operation beyond the maximum operating conditions for extended periods may affect product reliability.

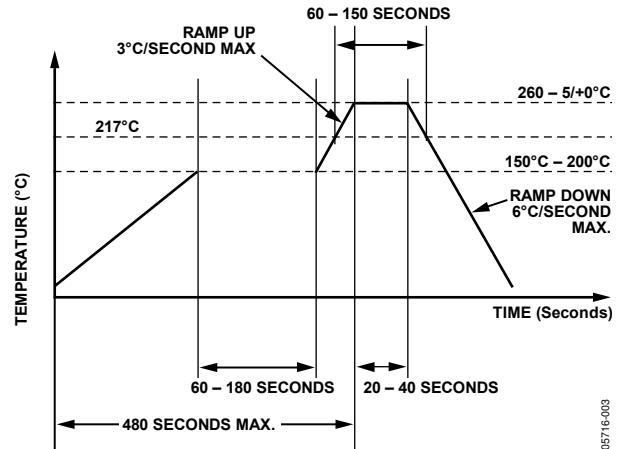

Figure 3. LFCSP Pb-Free Reflow Profile Based on JEDEC J-STD-20C

ESD CAUTION



ESD (electrostatic discharge) sensitive device. Charged devices and circuit boards can discharge without detection. Although this product features patented or proprietary protection circuitry, damage may occur on devices subjected to high energy ESD. Therefore, proper ESD precautions should be taken to avoid performance degradation or loss of functionality.

PIN CONFIGURATION AND FUNCTION DESCRIPTIONS

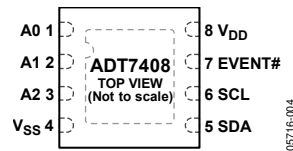

Figure 4. Pin Configuration

Table 4. Pin Function Descriptions

Pin No.	Mnemonic	Description
1	A0	SMBus/I ² C Serial Bus Address Selection Pin. Logic input. Can be set to V_{SS} or V_{DD} .
2	A1	SMBus/I ² C Serial Bus Address Selection Pin. Logic input. Can be set to V_{SS} or V_{DD} .
3	A2	SMBus/I ² C Serial Bus Address Selection Pin. Logic input. Can be set to V_{SS} or V_{DD} .
4	V_{SS}	Negative Supply or Ground.
5	SDA	SMBus/I ² C Serial Data Input/Output. Serial data to be loaded into the registers of this device and read from these registers is provided on this pin. Open-drain configuration; it needs a pull-up resistor.
6	SCL	Serial Clock Input. This is the clock input for the serial port. The serial clock is used to clock data into and clock data out from any register of the ADT7408. Open-drain configuration needs a pull-up resistor.
7	EVENT#	Active Low. Open-drain event output pin. Driven low on comparator level or alert interrupt.
8	V_{DD}	Positive Supply Power. Decouple the supply to ground.

TYPICAL PERFORMANCE CHARACTERISTICS

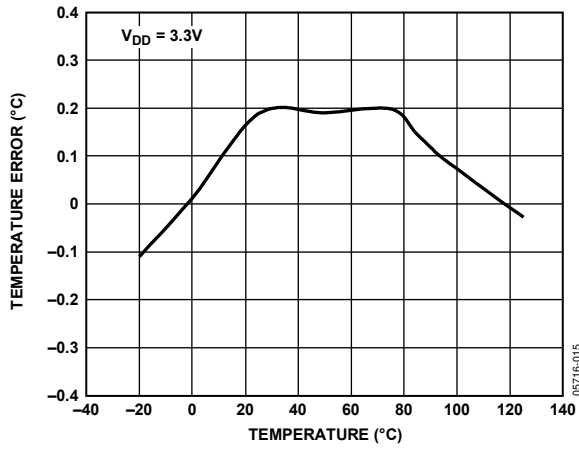

Figure 5. Temperature Accuracy

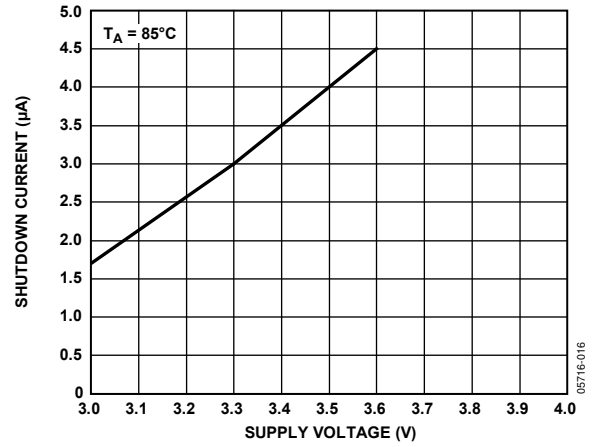

Figure 8. Shutdown Current vs. Supply Voltage

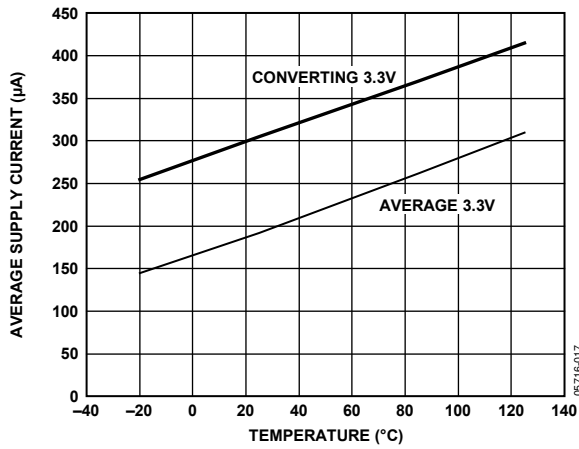

Figure 6. Supply Current vs. Temperature

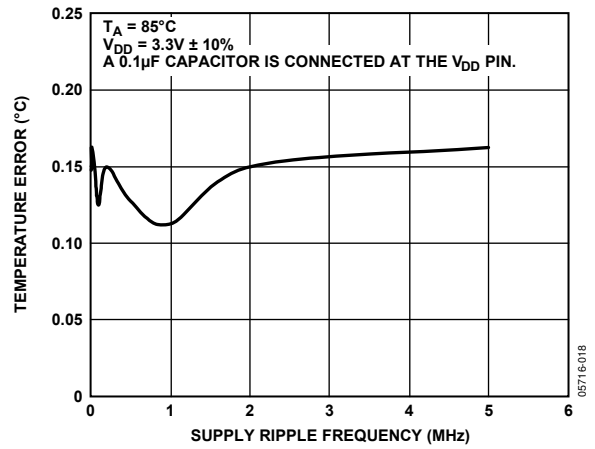

Figure 9. Temperature Accuracy vs. Supply Ripple Frequency

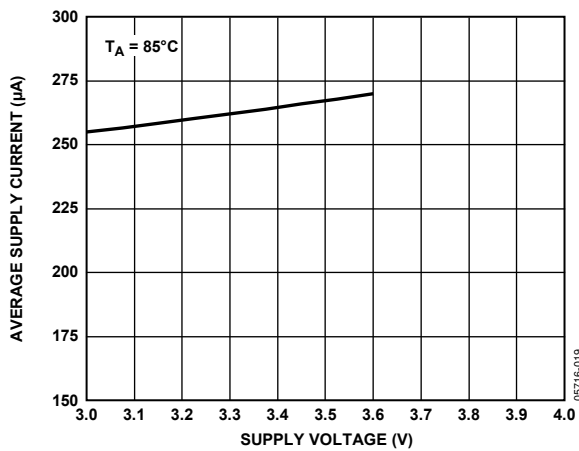

Figure 7. Supply Current vs. Supply Voltage

THEORY OF OPERATION

CIRCUIT INFORMATION

The ADT7408 is a 12-bit digital temperature sensor presented in 13 bits, including the sign bit format (see the bit map in the Temperature Value Register (Read Only) section). Its output is two's complement in that Bit D12 is the sign bit and Bit D0 to Bit D11 are data bits. An on-board sensor generates a voltage precisely proportional to absolute temperature, which is compared to an internal voltage reference and input to a precision digital modulator. Overall accuracy for the ADT7408 is $\pm 2^{\circ}\text{C}$ from $+75^{\circ}\text{C}$ to $+95^{\circ}\text{C}$, $\pm 3^{\circ}\text{C}$ from $+40^{\circ}\text{C}$ to $+125^{\circ}\text{C}$, and $\pm 4^{\circ}\text{C}$ from -20°C to $+125^{\circ}\text{C}$, with excellent transducer linearity. The serial interface is SMBus/I²C-compatible, and the open-drain output of the ADT7408 is capable of sinking 6 mA.

The on-board temperature sensor has excellent accuracy and linearity over the entire rated temperature range without needing correction or calibration by the user.

A first-order, Σ - Δ modulator, also known as the charge balance type analog-to-digital converter (ADC), digitizes the sensor output. This type of converter uses time domain oversampling and a high accuracy comparator to deliver 12 bits of effective accuracy in an extremely compact circuit.

CONVERTER DETAILS

The Σ - Δ modulator consists of an input sampler, a summing network, an integrator, a comparator, and a 1-bit DAC, as shown in Figure 10. This architecture creates a negative feedback loop that minimizes the integrator output by changing the duty cycle of the comparator output in response to input voltage changes. There are two simultaneous but different sampling operations in the device. The comparator samples the output of the integrator at a much higher rate than the input sampling frequency, that is, oversampling. Oversampling spreads the quantization noise over a much wider band than that of the input signal, improving overall noise performance and increasing accuracy.

The modulated output of the comparator is encoded using a circuit technique that results in SMBus/I²C temperature data.

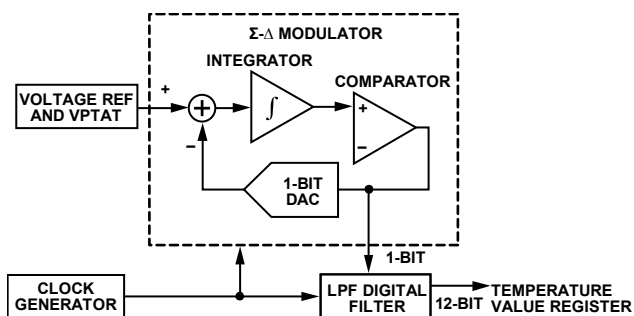

Figure 10. First-Order, Σ - Δ Modulator

05716-005

MODES OF OPERATION

The conversion clock for the part is internally generated. No external clock is required except when reading from and writing to the serial port. In normal mode, the internal clock oscillator runs an automatic conversion sequence that initiates a conversion every 100 ms. At this time, the part powers up its analog circuitry and performs a temperature conversion. This temperature conversion typically takes 60 ms, after which time the analog circuitry of the part automatically shuts down. The analog circuitry powers up again 40 ms later, when the 100 ms timer times out and the next conversion begins. Because the SMBus/I²C circuitry never shuts down, the result of the most recent temperature conversion is always available in the temperature value register.

The ADT7408 can be placed in shutdown mode via the configuration register, in which case the on-chip oscillator is shut down, and no further conversions are initiated until the ADT7408 is taken out of shutdown mode by writing 0 to Bit D8 in the configuration register. The conversion result from the last conversion prior to shutdown can still be read from the ADT7408, even when it is in shutdown mode.

In normal conversion mode, the internal clock oscillator is reset after every read or write operation. This causes the device to start a temperature conversion, the result of which is typically available 60 ms later. Similarly, when the part is taken out of shutdown mode, the internal clock oscillator starts, and a conversion is initiated. The conversion result is typically available 60 ms later. Reading from the device before a conversion is complete does not stop the ADT7408 from converting; the part does not update the temperature value register immediately after the conversion but waits until communication to the part is finished. This read operation provides the previous result. It is possible to miss a conversion result if the SCL frequency is very slow (communication is greater than 40 ms), because the next conversion will have started. There is a 40 ms window between the end of one conversion and the start of the next conversion for the temperature value register to be updated with a new temperature value.

The measured temperature value is compared with the temperature set at the alarm temperature upper boundary trip register, the alarm temperature lower boundary trip register, and the critical temperature trip register. If the measured value exceeds these limits, then the EVENT# pin is activated. This EVENT# output is programmable for interrupt mode, comparator mode, and the output polarity via the configuration register.

The thermal sensor continuously monitors the temperature and updates the temperature data 10 times per second. Temperature data is latched internally by the device and can be read by software from the bus host at any time.

SMBus/I²C slave address selection pins allow up to eight such devices to co-exist on the same bus. This means that up to eight memory modules can be supported, given that each module has one slave device address slot.

After initial power-on, the configuration registers are set to the default values. Software can write to the configuration register to set bits as per the bit definitions in the Registers section.

REGISTERS

The ADT7408 contains 16 accessible registers, shown in Table 5. The address pointer register is the only register that is eight bits; the other registers are 16 bits wide. On power-up, the address pointer register is loaded with 0x00 and points to the capability register.

Table 5. Registers

Pointer Address	Register Name	Power-On Default	Read/Write
Not Applicable	Address pointer	0x00	Write
0x00	Capability	0x001D	Read
0x01	Configuration	0x0000	Read/Write
0x02	Alarm temperature upper boundary trip	0x0000	Read/Write
0x03	Alarm temperature lower boundary trip	0x0000	Read/Write
0x04	Critical temperature trip	0x0000	Read/Write
0x05	Temperature value	Undefined	Read
0x06	Manufacturer ID	0x11D4	Read
0x07	Device ID/revision	0x080X	Read
0x08 to 0x0F	Vendor defined	0x0000	Reserved

ADDRESS POINTER REGISTER (WRITE ONLY)

This 8-bit write only register selects which of the 16-bit registers is accessed in subsequent read/write operations. Address space between 0x08 and 0x0F is reserved for factory usage.

MSB					LSB		
D7	D6	D5	D4	D3	D2	D1	D0
0	0	0	0	Register select	Register select	Register select	Register select

Table 6. Address Pointer Selected Registers

D2	D1	D0	Register Selected
0	0	0	Capability
0	0	1	Configuration
0	1	0	Alarm temperature upper boundary trip
0	1	1	Alarm temperature lower boundary trip
1	0	0	Critical temperature trip
1	0	1	Temperature value
1	1	0	Manufacturer ID
1	1	1	Device ID/revision

CAPABILITY REGISTER (READ ONLY)

This 16-bit, read-only register indicates the capabilities of the thermal sensor, as shown in Table 7 and the following bit map. Note that RFU means reserved for future use.

MSB											LSB				
D15	D14	D13	D12	D11	D10	D9	D8	D7	D6	D5	D4	D3	D2	D1	D0
RFU	RFU	RFU	RFU	RFU	RFU	RFU	RFU	RFU	RFU	RFU	TRES1	TRES0	Wider range	Higher precision	Alarm/critical trips

Table 7. Capability Mode Description

Bit(s)	Function
D0 (Alarm/Critical Trips)	Basic capability.
	D0 Trips Capability 1 Alarm and critical trips capability.
D1 (Higher Precision)	Accuracy.
	D1 Accuracy Capability 0 Default accuracy $\pm 2^{\circ}\text{C}$ over the active range and $\pm 3^{\circ}\text{C}$ over the monitor range.
D2 (Wider Range)	Wider range.
	D2 Temperature Range Capability 1 Can read temperature below 0°C and set sign bit accordingly (default).
[D4:D3] (Temperature Resolution)	Temperature resolution.
	[D4:D3] Temperature Resolution 01 0.25°C LSB. 11 0.0625°C LSB (default).
	[D15:D5] Reserved for future use; must be 0.

CONFIGURATION REGISTER (READ/WRITE)

This 16-bit read/write register stores various configuration modes for the [ADT7408](#), as shown in Table 8 and the following bit map. Note that RFU means reserved for future use.

MSB

LSB

D15	D14	D13	D12	D11	D10	D9	D8	D7	D6	D5	D4	D3	D2	D1	D0
RFU	RFU	RFU	RFU	RFU	Hysteresis		Shut-down mode	Critical lock bit	Alarm lock bit	Clear event	Event output status	Event output control	Critical event only	Event polarity	Event mode

Table 8. Configuration Mode Description

Bit(s)	Description
D0	Event mode. 0: comparator output mode (default). 1: interrupt mode. When either lock bit (D6 and D7) is set, this bit cannot be altered until unlocked.
D1	Event polarity. 0: active low (default). 1: active high. When either lock bit (D6 and D7) is set, this bit cannot be altered until unlocked.
D2	Critical event only. 0: event output on alarm or critical temperature event (default). 1: event only if temperature is above the value in the critical temperature trip register. When either lock bit (D6 and D7) is set, this bit cannot be altered until unlocked.
D3	Event output control. 0: event output disabled (default). 1: event output enabled. When either lock bit (D6 and D7) is set, this bit cannot be altered until unlocked.
D4	Event output status (read only). 0: event output condition is not being asserted by this device. 1: event output pin is being asserted by this device due to alarm window or critical trip condition. The actual cause of an event can be determined from the read of the temperature value register. Interrupt events can be cleared by writing to the clear event bit. Writing to this bit has no effect on the output status because it is a read function only.
D5	Clear event (write only). 0: no effect. 1: clears an active event in interrupt mode. Writing to this register has no effect in comparator mode. When read, this bit always returns 0. Once the DUT temperature is greater than the critical temperature, an event cannot be cleared (see Figure 12).
D6	Alarm window lock bit. 0: alarm trips are not locked and can be altered (default). 1: alarm trip register settings cannot be altered. This bit is initially cleared. When set, this bit returns a 1 and remains locked until cleared by internal power on reset. These bits can be written with a single write and do not require double writes.
D7	Critical trip lock bit. 0: critical trip is not locked and can be altered (default). 1: critical trip register settings cannot be altered. This bit is initially cleared. When set, this bit returns a 1 and remains locked until cleared by internal power on reset. These bits can be written with a single write and do not require double writes.
D8	Shutdown mode. 0: TS enabled (default). 1: TS shut down. When shut down, the thermal sensing device and ADC are disabled to save power. No events are generated. When either lock bit is set, this bit cannot be set until unlocked. However, it can be cleared at any time.

Bit(s)	Description
D10:D9	Hysteresis enable. 00: disable hysteresis. 01: enable hysteresis at 1.5°C. 10: enable hysteresis at 3°C. 11: enable hysteresis at 6°C.

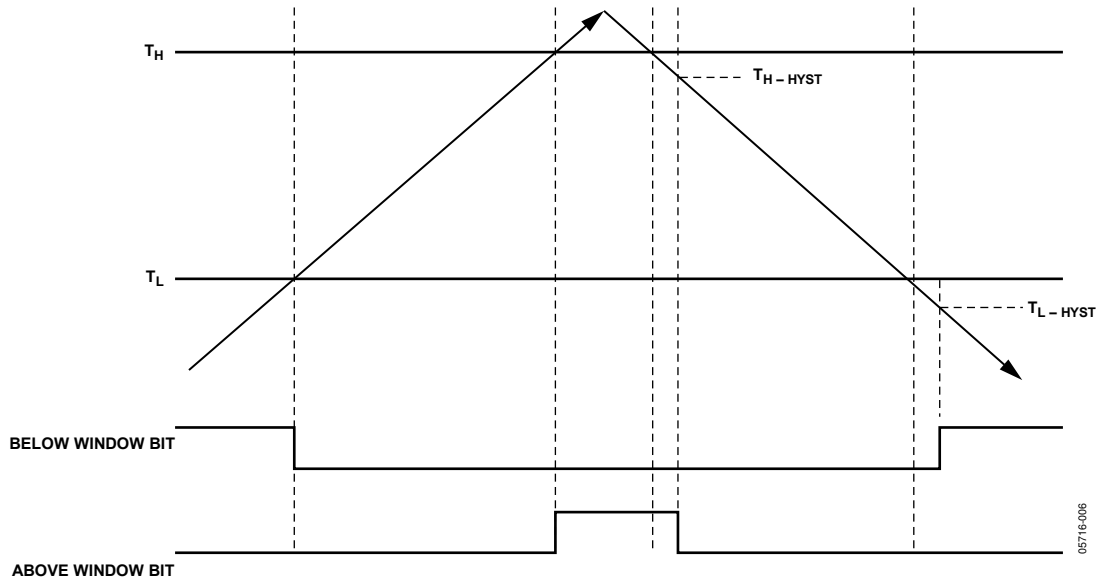

Figure 11. Hysteresis

05716-006

TEMPERATURE TRIP POINT REGISTERS

There are three temperature trip point registers. They are the alarm temperature upper boundary trip register, the alarm temperature lower boundary trip register, and the critical temperature trip register.

Alarm Temperature Upper Boundary Trip Register (Read/Write)

The value is the upper threshold temperature value for alarm mode. The data format is twos complement with one LSB = 0.25°C. RFU (reserved for future use) bits are not supported and always report 0. Interrupts respond to the programmed boundary values. If boundary values are being altered in-system, the user should turn off interrupts until a known state can be obtained to avoid superfluous interrupt activity. The format of this register is shown in the following bit map:

Sign MSB			LSB												
D15	D14	D13	D12	D11	D10	D9	D8	D7	D6	D5	D4	D3	D2	D1	D0
0	0	0	Alarm window upper boundary temperature											RFU	RFU

Alarm Temperature Lower Boundary Trip Register (Read/Write)

The value is the lower threshold temperature value for alarm mode. The data format is twos complement with one LSB = 0.25°C. RFU bits are not supported and always report 0. Interrupts respond to the programmed boundary values. If boundary values are being altered in-system, the user should turn off interrupts until a known state can be obtained to avoid superfluous interrupt activity. The format of this register is shown in the following bit map:

Sign MSB			LSB												
D15	D14	D13	D12	D11	D10	D9	D8	D7	D6	D5	D4	D3	D2	D1	D0
0	0	0	Alarm window upper boundary temperature											RFU	RFU

Critical Temperature Trip Register (Read/Write)

The value is the critical temperature. The data format is twos complement with one LSB = 0.25°C. RFU bits are not supported and always report 0. The format of this register is shown in the following bit map:

Sign MSB			LSB												
D15	D14	D13	D12	D11	D10	D9	D8	D7	D6	D5	D4	D3	D2	D1	D0
0	0	0	Critical temperature trip point											RFU	RFU

Temperature Value Register (Read Only)

This 16-bit, read-only register stores the trip status and the temperature measured by the internal temperature sensor, as shown in Table 9. The temperature is stored in 13-bit, twos complement format with the MSB being the temperature sign bit and the 12 LSBs representing temperature. One LSB = 0.0625°C. The most significant bit has a resolution of 128°C.

When reading from this register, the eight MSBs (Bit D15 to Bit D8) are read first, and then the eight LSBs (Bit D7 to Bit D0) are read.

The trip status bits represent the internal temperature trip detection and are not affected by the status of the event or configuration bits, for example, event output control, clear event. If both above and below are 0, then the current temperature is exactly within the alarm window boundaries, as defined in the configuration register. The format and descriptions are shown in Table 9 and the following bit map:

Sign MSB			LSB												
D15	D14	D13	D12	D11	D10	D9	D8	D7	D6	D5	D4	D3	D2	D1	D0
Above critical trip	Above alarm window	Below alarm window	Temperature												

Table 9. Temperature Register Trip Status Description

Bit	Definition	
D13 (Below Alarm Window)	Below alarm window.	
	D13	Temperature Alarm Status
	0	Temperature is equal to or above the alarm window lower boundary temperature.
	1	Temperature is below the alarm window lower boundary temperature.
D14 (Above Alarm Window)	Above alarm window	
	D14	Temperature Alarm Status
	0	Temperature is equal to or below the alarm window upper boundary temperature.
	1	Temperature is above the alarm window upper boundary temperature.
D15 (Above Critical Trip)	Above critical trip	
	D15	Critical Trip Status
	0	Temperature is below the critical temperature setting.
	1	Temperature is equal to or above the critical temperature setting.

ID REGISTERS

Manufacturer ID Register (Read Only)

This manufacturer ID matches that assigned to a vendor within the PCI SIG. This register can be used to identify the manufacturer of the device in order to perform manufacturer-specific operations. Manufacturer IDs can be found at www.pcisig.com. The format of this register is shown in the following bit map:

D15	D14	D13	D12	D11	D10	D9	D8	D7	D16	D5	D4	D3	D2	D1	D0
0	0	0	1	0	0	0	1	1	1	0	1	0	1	0	0

Device ID and Revision Register (Read Only)

This device ID and device revision are assigned by the device manufacturer. The device revision starts at 0 and is incremented by 1 whenever an update to the device is issued by the manufacturer. The format of this register is shown in the following bit map:

D15	D14	D13	D12	D11	D10	D9	D8	D7	D6	D5	D4	D3	D2	D1	D0
0	0	0	0	1	0	0	0	0	0	0	0	0	0	0	1

TEMPERATURE DATA FORMAT

The values used in the temperature register and three temperature trip point registers are in twos complement format. The temperature register has a 12-bit resolution with 256°C range with 1 LSB = 0.0625°C ($256^{\circ}\text{C}/2^{12}$); see Table 10. The temperature data in the three temperature trip point registers (alarm upper, alarm lower, and critical) is a 10-bit format with 256°C range with 1 LSB = 0.25°C (see the bit maps in the Alarm Temperature Lower Boundary Trip Register (Read/Write) section, the Critical Temperature Trip Register (Read/Write) section, and the Temperature Value Register (Read Only) section.) Bit D12 in all these registers represents the sign bit such that 0 = positive temperature and 1 = negative temperature. In twos complement format, the data bits are inverted and add 1 if Bit D12 (the sign bit) is negative.

Temperature Conversion Formulas

12-Bit Temperature Data Format

$$\text{Positive Temperature} = \text{ADC Code}(d)/16 \quad (1)$$

$$\text{Negative Temperature} = (\text{ADC Code}(d) - 4096)/16 \quad (2)$$

where d is the 12-bit digital output in decimal.

Note that Bit D12 (the sign bit) is not included in the ADC code, but the sign is inserted in the final result.

Table 10 tabulates some temperature results vs. digital outputs.

10-Bit Temperature Data Format

$$\text{Positive Temperature} = \text{ADC Code}(d)/4 \quad (3)$$

$$\text{Negative Temperature} = (\text{ADC Code}(d) - 1024)/4 \quad (4)$$

Similarly, Bit D12 (the sign bit) is not included in the ADC code, but the sign is inserted in the final result. This ADC code contains DB2 to DB11. DB0 to DB1 are not in this calculation.

Although one LSB of the ADC corresponds to 0.0625°C, the ADC can theoretically measure a temperature range of 255°C (−128°C to +127°C). The ADT7408 is guaranteed to measure a low value temperature limit of −55°C to a high value temperature limit of +125°C.

Reading back the temperature from the temperature value register requires a 2-byte read.

Designers accustomed to using a 9-bit temperature data format can still use the ADT7408 by ignoring the last three LSBs of the 12-bit temperature value.

Table 10. 12-Bit Temperature Data Format

Digital Output (Binary), D12 to D0	Digital Output (Hex)	Temperature
1 1100 1001 0000	C90	−55°C
1 1100 1110 0000	CE0	−50°C
1 1110 0110 1111	E6F	−25°C
1 1111 1111 1111	FFF	−0.0625°C
0 0000 0000 0000	000	0°C
0 0000 0000 0001	0x001	+0.0625°C
0 0000 1010 0000	0x0A0	+10°C
0 0001 1001 0000	0x190	+25°C
0 0011 0010 0000	0x320	+50°C
0 0100 1011 0000	0x4B0	+75°C
0 0110 0100 0000	0x640	+100°C
0 0111 1101 0000	0x7D0	+125°C

EVENT PIN FUNCTIONALITY

Figure 12 shows the three differently defined outputs of EVENT# corresponding to the temperature change. EVENT# can be programmed to be one of the three output modes in the configuration register.

If while in interrupt mode the temperature reaches the critical temperature, the device switches to the comparator mode automatically and asserts the EVENT# output. When the temperature drops below the critical temperature, the part switches back to either interrupt mode or comparator mode, as programmed in the configuration register.

Note that Figure 12 is drawn with no hysteresis, but the values programmed into Configuration Register 0x01, Bits[10:9] affect the operation of the event trigger points. See Figure 11 for the explanation of hysteresis functionality.

Event Thresholds

All event thresholds use hysteresis as programmed in the Configuration Register 0x01, Bits[10:9] to set when they deassert.

Alarm Window Trip

The device provides a comparison window with an upper temperature trip point in the alarm upper boundary register and a lower trip point in the alarm lower boundary register. When enabled, the EVENT# output is triggered whenever entering or exiting (crossing above or below) the alarm window.

Critical Trip

The device can be programmed in such a way that the EVENT# output is triggered only when the temperature exceeds critical trip point. The critical temperature setting is programmed in the critical temperature register. When the temperature sensor reaches the critical temperature value in this register, the device is automatically placed in comparator mode, meaning that the critical event output cannot be cleared through software by setting the clear event bit.

Interrupt Mode

After an event occurs, software can write a 1 to the clear event bit in the configuration register to de-assert the EVENT# interrupt output, until the next trigger condition occurs.

Comparator Mode

Reads/writes on the device registers do not affect the EVENT# output in comparator mode. The EVENT# signal remains asserted until the temperature drops outside the range or until the range is reprogrammed such that the current temperature is outside the range.

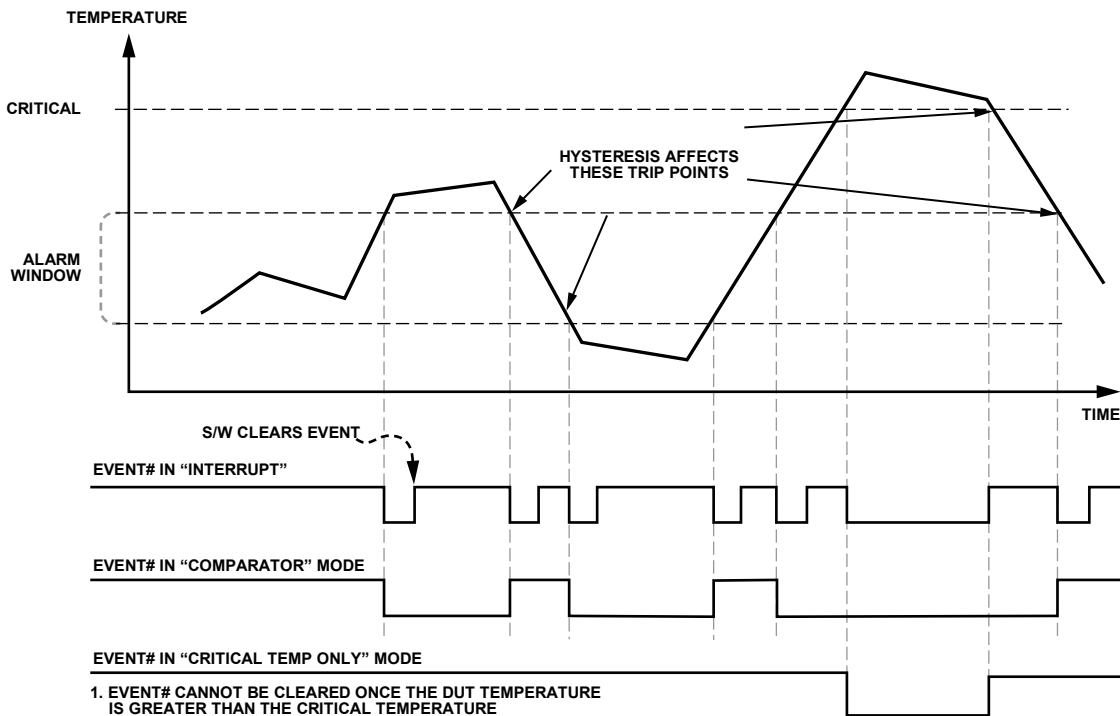

Figure 12. Temperature, Trip, and Events

SERIAL INTERFACE

Control of the ADT7408 is carried out via the SMBus-/I²C-compatible serial interface. The ADT7408 is connected to this bus as a slave and is under the control of a master device.

Figure 13 shows a typical SMBus/I²C interface connection.

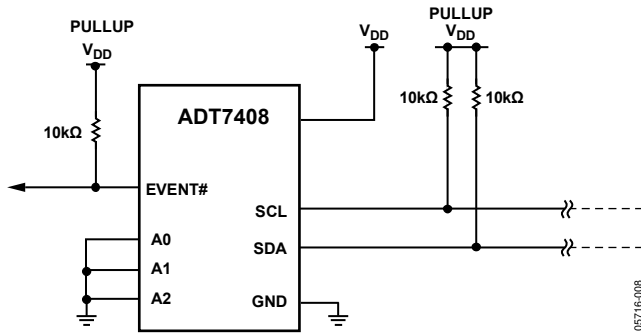

Figure 13. Typical SMBus/I²C Interface Connection

Serial Bus Address

Like all SMBus-/I²C-compatible devices, the ADT7408 has a 7-bit serial address. The four MSBs of this address for the ADT7408 are set to 0011. Pin 1, Pin 2, and Pin 3 (A0, A1, and A2) set the three LSBs. These pins can be configured either low or high, permanently or dynamically, to give eight different address options. Table 11 shows the different bus address options available. Recommended pull-up resistor value on the SDA and SCL lines is 2.2 kΩ to 10 kΩ.

Table 11. SMBus/I²C Bus Address Options

Binary, A6 to A0	Hex Address
0011 0 0 0	0x18
0011 0 0 1	0x19
0011 0 1 0	0x1A
0011 0 1 1	0x1B
0011 1 0 0	0x1C
0011 1 0 1	0x1D
0011 1 1 0	0x1E
0011 1 1 1	0x1F

The ADT7408 has been designed with a SMBus/I²C timeout. The SMBus/I²C interface times out after 75 ms to 100 ms of no activity on the SDA line. After this timeout the ADT7408 resets the SDA line back to its idle state (SDA set to high impedance) and waits for the next start condition.

The serial bus protocol operates as follows:

1. The master initiates data transfer by establishing a start condition, defined as a high-to-low transition on the serial data line SDA, while the serial clock line, SCL, remains high. This indicates that an address/data stream follows. All slave peripherals connected to the serial bus respond to the start condition and shift in the next eight bits, consisting of a 7-bit address (MSB first) plus a R/W bit. The R/W bit determines whether data is written to, or read from, the slave device.
2. The peripheral with the address corresponding to the transmitted address responds by pulling the data line low during the low period before the ninth clock pulse, known as the acknowledge bit. All other devices on the bus now remain idle while the selected device waits for data to be read from or written to it. If the R/W bit is a 0, then the master writes to the slave device. If the R/W bit is a 1, the master reads from the slave device.
3. Data is sent over the serial bus in sequences of nine clock pulses: eight bits of data followed by an acknowledge bit from the receiver of data. Transitions on the data line must occur during the low period of the clock signal and remain stable during the high period, because a low to high transition when the clock is high can be interpreted as a stop signal.
4. When all data bytes have been read or written, stop conditions are established. In write mode, the master pulls the data line high during the 10th clock pulse to assert a stop condition. In read mode, the master device pulls the data line high during the low period before the ninth clock pulse. This is known as no acknowledge. The master then takes the data line low during the low period before the 10th clock pulse, then high during the 10th clock pulse to assert a stop condition.

Any number of bytes of data can be transferred over the serial bus in one operation. However, it is not possible to mix read and write in one operation because the type of operation is determined at the beginning and cannot subsequently be changed without starting a new operation.

The I²C address set up by the three address pins is not latched by the device until after this address has been sent twice. On the eighth SCL cycle of the second valid communication, the serial bus address is latched in. This is the SCL cycle directly after the device has seen its own I²C serial bus address. Any subsequent changes on this pin have no effect on the I²C serial bus address.

SMBUS/I²C COMMUNICATIONS

The pointer register selects the data registers in the ADT7408. At power-up, the pointer register is set to 0x00, the location for the capability register. The pointer register latches the last location to which it was set. Each data register falls into one of the following three types of user accessibility:

- Read only
- Write only
- Write/read same address

A write to the ADT7408 always includes the address byte and the pointer byte. A write to any register other than the pointer register requires two data bytes.

Reading data from the ADT7408 occurs in one of the following two ways:

- If the location latched in the pointer register is correct, then the read simply consists of an address byte, followed by retrieving the two data bytes.
- If the pointer register needs to be set, then an address byte, pointer byte, repeat start, and another address byte accomplish a read.

The data byte has the most significant bit first. At the end of a read, the ADT7408 accepts either acknowledge (ACK) or no acknowledge (NO ACK) from the master. No acknowledge is typically used as a signal for the slave that the master has read its last byte. It typically takes the ADT7408 100 ms to measure the temperature.

Writing Data to a Register

With the exception of the pointer register, all other registers are 16 bits wide, so two bytes of data are written to these registers. Writing two bytes of data to these registers consists of the serial bus address, the data register address written to the pointer register, followed by the two data bytes written to the selected data register (see Figure 14). If more than the required number of data bytes is written to a register, then the register ignores these extra data bytes. To write to a different register, another start or repeated start is required.

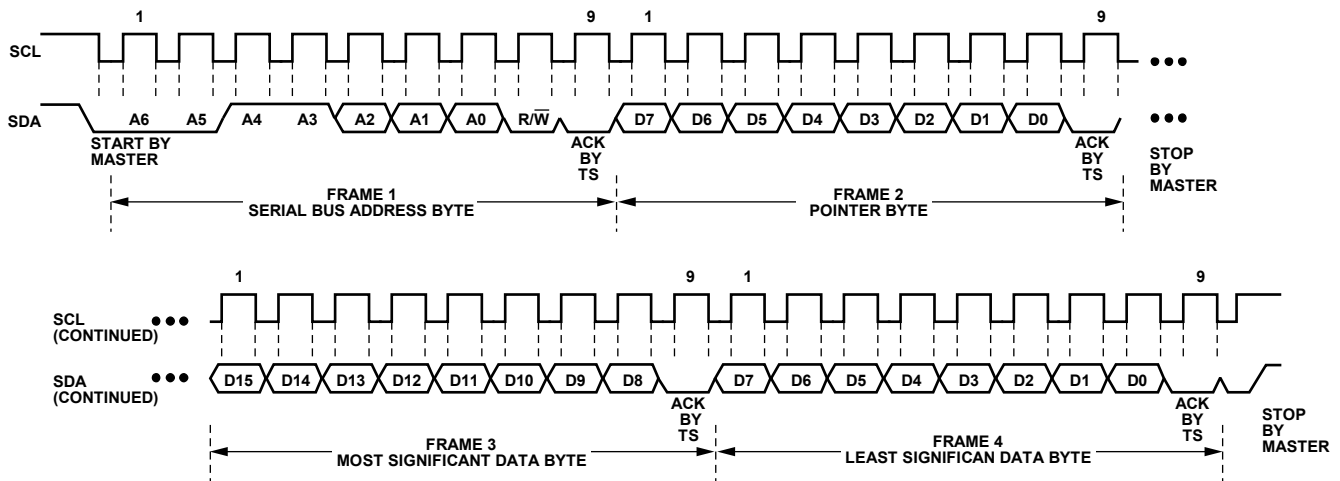

Figure 14. Writing to the Address Pointer Register, Followed by Two Bytes of Data

05716-009

Reading Data From the ADT7408

Reading data from the ADT7408 can take place in one of the following two ways:

Writing to the Pointer Register for a Subsequent Read

To read data from a particular register, the pointer register must contain the address of the data register. If it does not, the correct address must be written to the address pointer register by performing a single-byte write operation (see Figure 15).

The write operation consists of the serial bus address followed by the pointer byte. No data is written to any of the data registers. Because the location latched in the pointer register is correct, then the read consists of an address byte, followed by retrieving the two data bytes (see Figure 16).

Reading from Any Pointer Register

On the other hand, if the pointer register needs to be set, then an address byte, pointer byte, repeat start, and another address byte accomplish a read (see Figure 17).

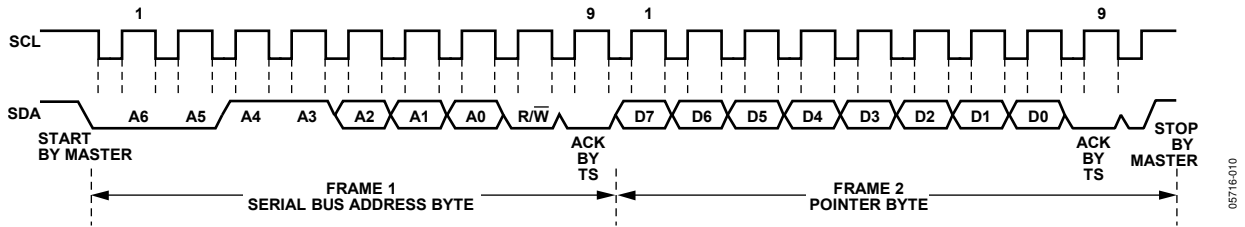

Figure 15. Writing to the Address Pointer Register to Select a Register for a Subsequent Read Operation

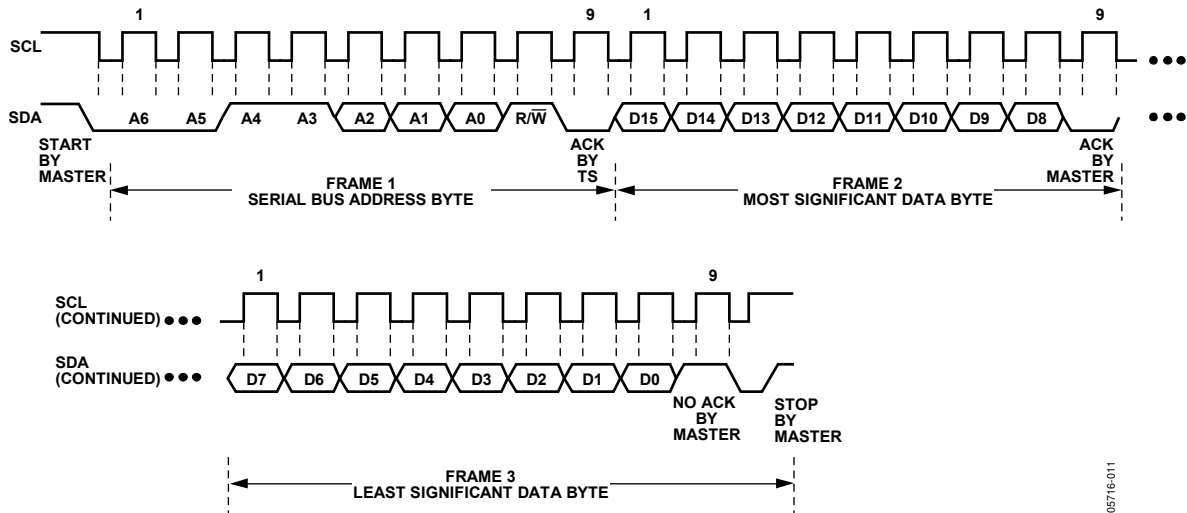

Figure 16. Reading Back Data from the Register with the Preset Pointer

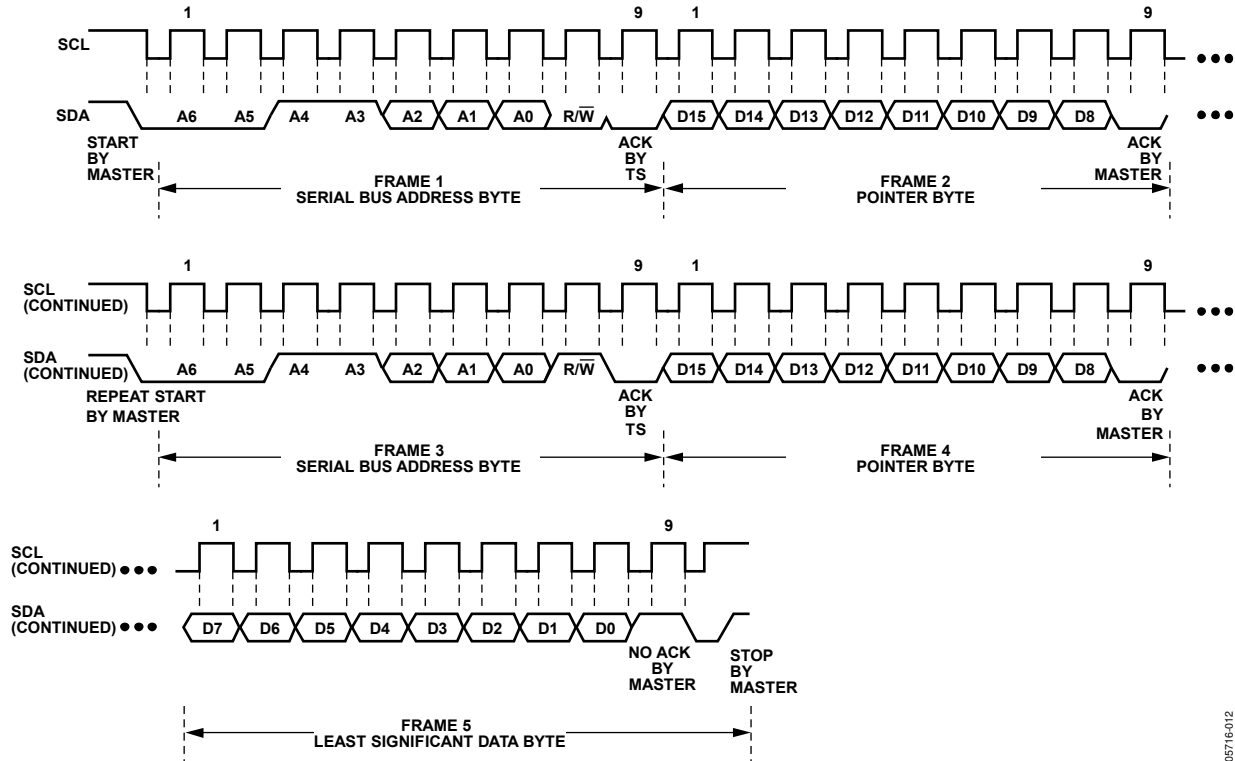

Figure 17. A Write to the Pointer Register Followed by a Repeat Start and an Immediate Data-Word Read

05716-012

APPLICATIONS INFORMATION

THERMAL RESPONSE TIME

The time required for a temperature sensor to settle to a specified accuracy is a function of the thermal mass of the sensor and the thermal conductivity between the sensor and the object being sensed. Thermal mass is often considered equivalent to capacitance. Thermal conductivity is commonly specified using the symbol Q and can be thought of as thermal resistance. It is commonly specified in units of degrees per watt of power transferred across the thermal joint. Thus, the time required for the ADT7408 to settle to the desired accuracy is dependent on the package selected, the thermal contact established in that particular application, and the equivalent power of the heat source. In most applications, the settling time is best determined empirically.

SELF-HEATING EFFECTS

The temperature measurement accuracy of the ADT7408 may be degraded in some applications due to self-heating. Errors can be introduced from the quiescent dissipation and power dissipated when converting. The magnitude of these temperature errors is dependent on the thermal conductivity of the ADT7408 package, the mounting technique, and the effects of airflow. At 25°C, static dissipation in the ADT7408 is typically 778 μ W operating at 3.3 V. In the 8-lead LFCSP package mounted in free air, this accounts for a temperature increase due to self-heating of

$$\Delta T = P_{DISS} \times \theta_{JA} = 778 \mu\text{W} \times 85^\circ\text{C}/\text{W} = 0.066^\circ\text{C}$$

Current dissipated through the device must be kept to a minimum by applying shutdown when the device can be put in the idle state, because it has a proportional effect on the temperature error.

SUPPLY DECOUPLING

Decouple the ADT7408 with a 0.1 μ F ceramic capacitor between V_{DD} and GND. This is particularly important when the ADT7408 is mounted remotely from the power supply. Precision analog products, such as the ADT7408, require a well-filtered power source. Because the ADT7408 operates from a single supply, it might seem convenient to tap into the digital logic power supply.

Unfortunately, the logic supply is often a switch-mode design, which generates noise in the 20 kHz to 1 MHz range. In addition, fast logic gates can generate glitches hundreds of mV in amplitude due to wiring resistance and inductance.

If possible, power the ADT7408 directly from the system power supply. This arrangement, shown in Figure 18, isolates the analog section from the logic switching transients. Even if a separate power supply trace is not available, however, generous supply bypassing reduces supply line, induced errors.

To achieve the temperature accuracy specifications, local supply bypassing consisting of a 0.1 μ F ceramic capacitor is critical.

Place this decoupling capacitor as close as possible to the ADT7408 V_{DD} pin.

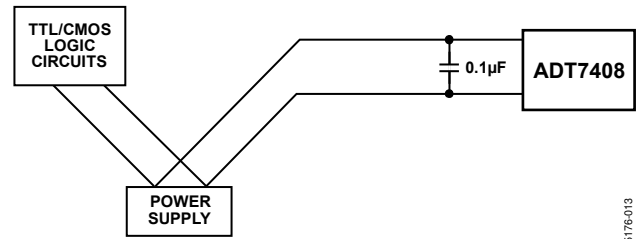

Figure 18. Using Separate Traces to Reduce Power Supply Noise

TEMPERATURE MONITORING

The ADT7408 is ideal for monitoring the thermal environment within electronic equipment. For example, the surface-mounted package accurately reflects the exact thermal conditions that affect nearby integrated circuits.

The ADT7408 measures and converts the temperature at the surface of its own semiconductor chip. When the ADT7408 is used to measure the temperature of a nearby heat source, the thermal impedance between the heat source and the ADT7408 must be considered. Often, a thermocouple or other temperature sensor is used to measure the temperature of the source, while the temperature is monitored by reading back from the ADT7408 temperature value register.

Once the thermal impedance is determined, the heat source temperature can be inferred from the ADT7408 output. As much as 60% of the heat transferred from the heat source to the thermal sensor on the ADT7408 die is discharged via the copper tracks, the package pins, and the bond pads. Of the pins on the ADT7408, the GND pin (V_{SS} pin) transfers most of the heat. Therefore, when the temperature of a heat source is being measured, thermal resistance between the ADT7408 V_{SS} pin and the heat source should be reduced as much as possible.

An example of the unique properties of the ADT7408 are shown in monitoring a high power dissipation DIMM module. Ideally, the ADT7408 device must be mounted in the middle between the major heat sources of the two memory chips (see Figure 19). The ADT7408 produces a linear temperature output, while needing only two input/output pins and requiring no external characterization.

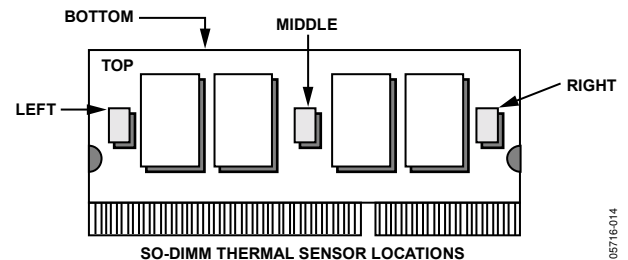
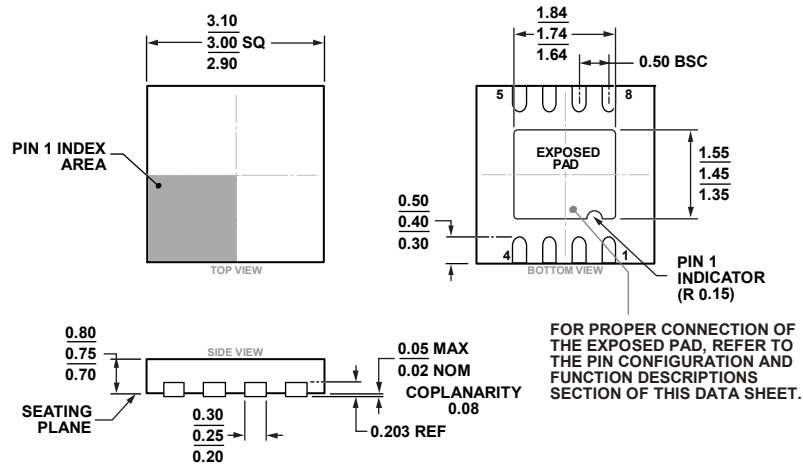

Figure 19. Locations of ADT7408 on DIMM Module

OUTLINE DIMENSIONS



COMPLIANT TO JEDEC STANDARDS MO-229-WEED-4

Figure 20. 8-Lead Frame Chip Scale Package [LFCSP]
3 mm x 3 mm Body and 0.75 mm Package Height
(CP-8-13)

Dimensions shown in millimeters

05-11-2016-A

ORDERING GUIDE

Model ¹	Temperature Range	Temperature Accuracy ²	Package Description	Package Option	Ordering Quantity	Branding
ADT7408CCPZ-REEL7	-20°C to +125°C	±2°C	8-Lead LFCSP	CP-8-13	1500	T1M

¹ Z = RoHS Compliant Part.

² Temperature accuracy is over the 75°C to 95°C temperature range.

²C refers to a communications protocol originally developed by Philips Semiconductors (now NXP Semiconductors).