

DO NOT SCALE FROM THIS PRINT

HTS-1XX-X-X-X-X-X

NO OF POSITIONS
-01 THRU -36

OPTION
-N: NON-FLUSH
(USE SSB-32-U BODY)
(LEAVE BLANK FOR STANDARD)

PLATING SPECIFICATION
-G: 20µ" SELECTIVE GOLD
(USE HTS-36-G)
-T: MATTE TIN
(USE HTS-36-L)
(USE HSS-36-L FOR
STYLES -J, -L-X, -M)

TERMINAL STYLE
(SEE TABLE 1)

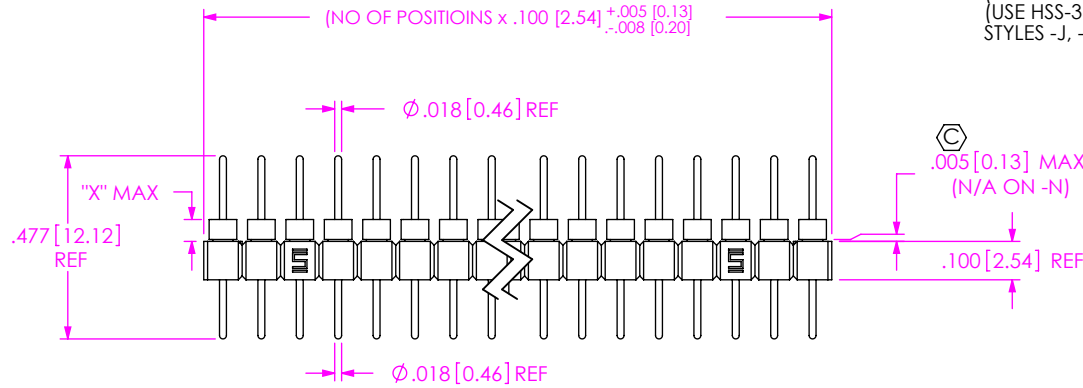

FIG 1
HTS-120-X-AA SHOWN

TABLE 1

TERMINAL STYLE	TERMINAL	SEE FIG NO -XX	SHEET	BODY	"X" (-N OPTION ONLY)	PACKAGING TUBE	PLUG
-AA	T-1R5-X	1	1	HTS-36-X	0.028 [0.71]	PT-1-24-01-24	TP-24
-A	T-1R0-X	2	2	HTS-36-X	0.028 [0.71]	PT-1-24-01-24	TP-24
-A-1	T-1R7-1-X	3	2	HTS-36-X	0.028 [0.71]	PT-1-24-01-24	TP-24
-A-2	T-1R7-2-X	4	2	HTS-36-X	0.028 [0.71]	PT-1-24-01-24	TP-24
-B	T-1R1-X	5	2	HTS-36-X	0.210 [5.33]	PT-1-24-01-24	TP-24
-B-2	T-1R8-2-X	6	2	HTS-36-X	0.210 [5.33]	N/A	N/A
-C	T-1R2-X	7	2	HTS-36-X	0.035 [0.89]	PT-1-24-01-24	TP-24
-C-1	T-1R9-1-X	8	2	HTS-36-X	0.035 [0.89]	PT-FTSH001-DH	TP-24
-C-2	T-1R9-2-X	9	3	HTS-36-X	0.035 [0.89]	N/A	N/A
-E	T-1R12-X	12	3	HTS-36-X	N/A	N/A	N/A
-G-1	T-1R5-1-X	14	3	HTS-36-X	N/A	PT-1-24-01-24	TP-24
-J	S-1P1-X	15	4	HSS-36-L	0.038 [0.97]	PT-1-24-01-23	TP-12
-K	T-1R12-X	16	4	HTS-36-X	0.030 [0.76]	N/A	N/A
-L-1	S-1W1-1-X	17	4	HSS-36-L	0.038 [0.97]	N/A	N/A
-L-2	S-1W1-2-X	18	4	HSS-36-L	0.038 [0.97]	N/A	N/A
-L-3	S-1W1-3-X	19	4	HSS-36-L	0.038 [0.97]	N/A	N/A
-N	T-1R5-1-X	20	4	HTS-36-X	N/A	N/A	N/A

NOTES:

1. © REPRESENTS A CRITICAL DIMENSION.
2. MAXIMUM ALLOWABLE BOW: .004[0.10] IN/IN TOP TO BOTTOM
.008[0.20] IN/IN SIDE TO SIDE.
3. MINIMUM PUSHOUT FORCE: 5 LBS.
4. MAXIMUM ALLOWABLE TOE IN/OUT OF TERMINALS: 2°.
5. MAXIMUM ALLOWABLE FLASH AFTER REMOVAL OF CROSS BARS: .005[0.13].
6. FOR LEAD STYLES PACKAGED IN TUBES: PACKAGE -05 THRU -36 POSITIONS IN TUBES;
LAYER PACKAGE POSITIONS -01 THRU -04 (SEE TABLE 1).
7. MAXIMUM ALLOWABLE FLASH: .010[0.25].

UNLESS OTHERWISE SPECIFIED, DIMENSIONS ARE IN INCHES.
TOLERANCES ARE:
DECIMALS ANGLES
.XX: ±.01 [.3] 2°
.XXX: ±.005 [.13]
.XXXX: ±.0020 [.051]

PROPRIETARY NOTE
THIS DOCUMENT CONTAINS CONFIDENTIAL AND PROPRIETARY INFORMATION AND ALL DESIGN, MANUFACTURING, REPRODUCTION, USE, PATENT RIGHTS AND SALES RIGHTS ARE EXPRESSLY RESERVED BY SAMTEC, INC. THIS DOCUMENT SHALL NOT BE DISCLOSED, IN WHOLE OR PART, TO ANY UNAUTHORIZED PERSON OR ENTITY NOR REPRODUCED, TRANSFERRED OR INCORPORATED IN ANY OTHER PROJECT IN ANY MANNER WITHOUT THE EXPRESS WRITTEN CONSENT OF SAMTEC, INC.



520 PARK EAST BLVD., NEW ALBANY, IN 47150
PHONE: 812-944-6733 FAX: 812-948-5047
e-Mail: info@SAMTEC.com code 55322

MATERIAL: DO NOT SCALE DRAWING SHEET SCALE: 2:1
INSULATOR: LCP, UL 94 V0, COLOR: BLACK
TERMINAL: BRASS, 1/2 HARD

DESCRIPTION:
HIGH TEMP, TERMINAL STRIP ASSEMBLY

DWG. NO. HTS-1XX-X-X-X-X-X

BY: L.W. 01/05/1984 SHEET 1 OF 3

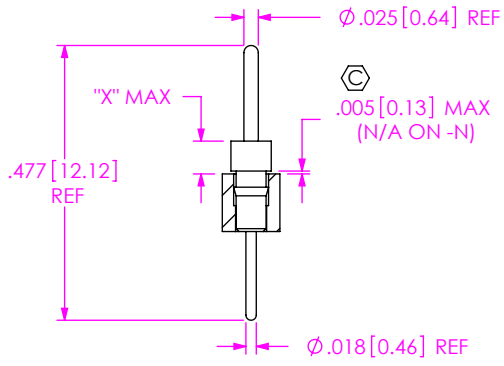

FIG 2
TERMINAL STYLE -A

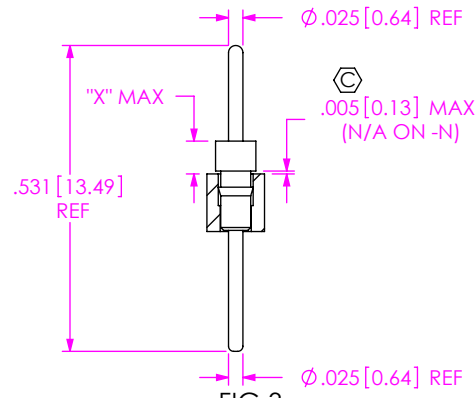

FIG 3
TERMINAL STYLE -A-1

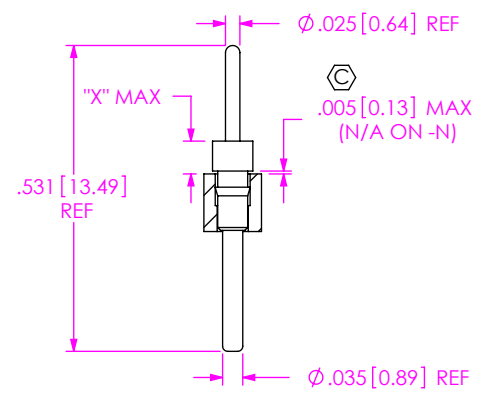

FIG 4
TERMINAL STYLE -A-2

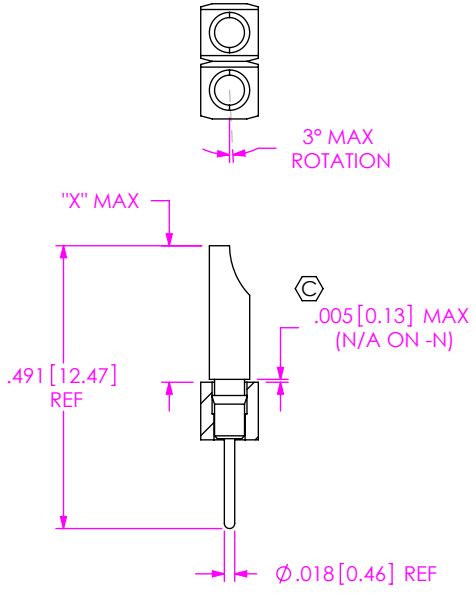

FIG 5
TERMINAL STYLE -B

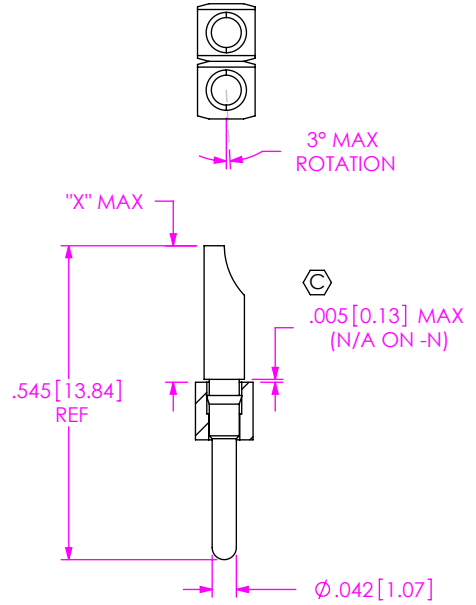

FIG 6
TERMINAL STYLE -B-2

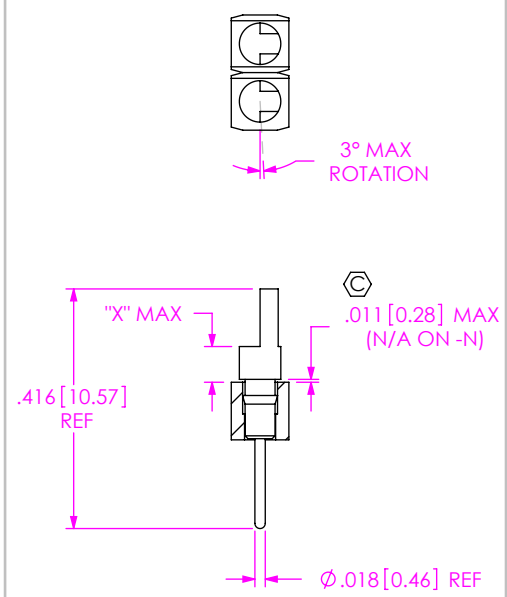

FIG 7
TERMINAL STYLE -C

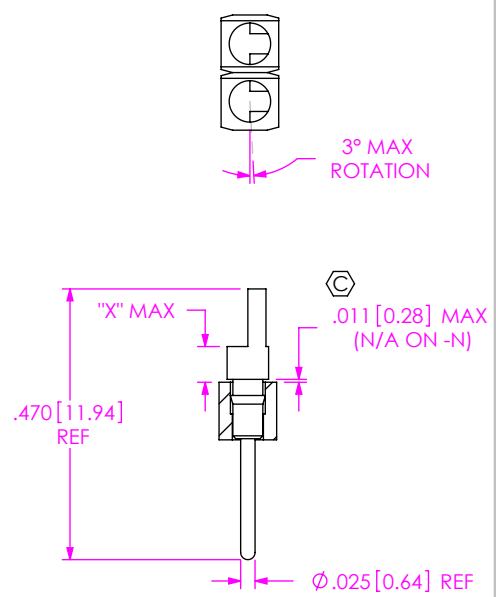

FIG 8
TERMINAL STYLE -C-1

PROPRIETARY NOTE
THIS DOCUMENT CONTAINS CONFIDENTIAL AND PROPRIETARY INFORMATION AND ALL DESIGN, MANUFACTURING, REPRODUCTION, USE, PATENT RIGHTS AND SALES RIGHTS ARE EXPRESSLY RESERVED BY SAMTEC, INC. THIS DOCUMENT SHALL NOT BE DISCLOSED, IN WHOLE OR PART, TO ANY UNAUTHORIZED PERSON OR ENTITY NOR REPRODUCED, TRANSFERRED OR INCORPORATED IN ANY OTHER PROJECT IN ANY MANNER WITHOUT THE EXPRESS WRITTEN CONSENT OF SAMTEC, INC.

DO NOT SCALE DRAWING

SHEET SCALE: 3:1



520 PARK EAST BLVD, NEW ALBANY, IN 47150
PHONE: 812-944-6733 FAX: 812-948-5047
e-Mail info@SAMTEC.com code 55322

DESCRIPTION:
HIGH TEMP, TERMINAL STRIP ASSEMBLY

DWG. NO. HTS-1XX-X-X-X-X-X

BY: L.W. 01/05/1984 SHEET 2 OF 3

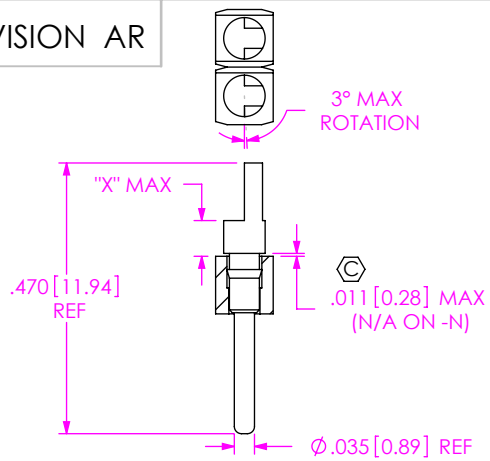

FIG 9
TERMINAL STYLE -C-2

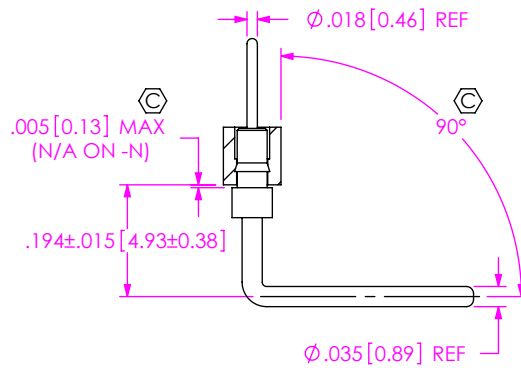

FIG 12
TERMINAL STYLE -E

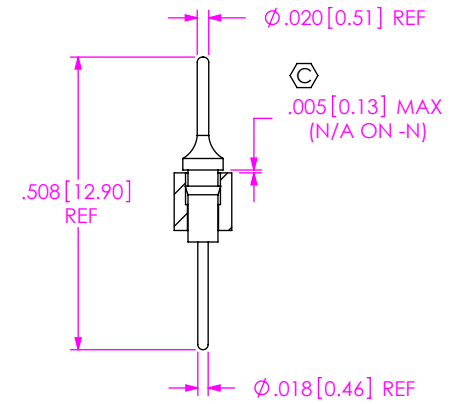

FIG 14
TERMINAL STYLE -G-1

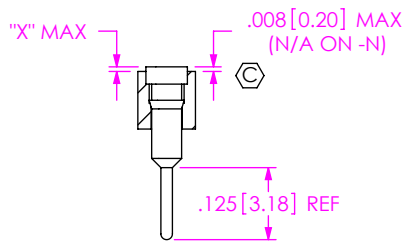

FIG 15
TERMINAL STYLE -J

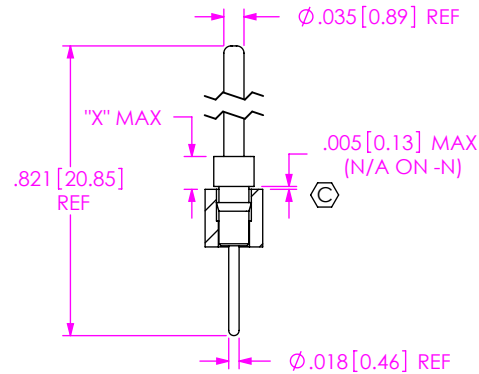

FIG 16
TERMINAL STYLE -K

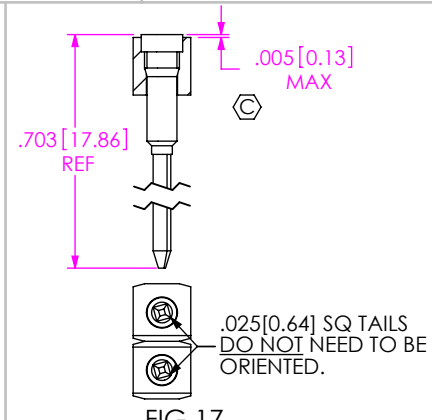

FIG 17
TERMINAL STYLE -L-1

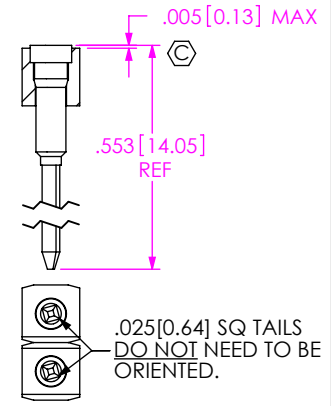

FIG 18
TERMINAL STYLE -L-2

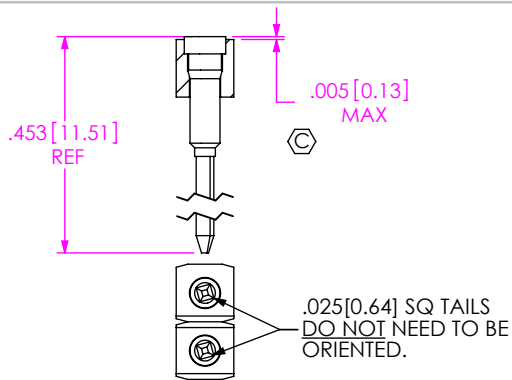

FIG 19
TERMINAL STYLE -L-3

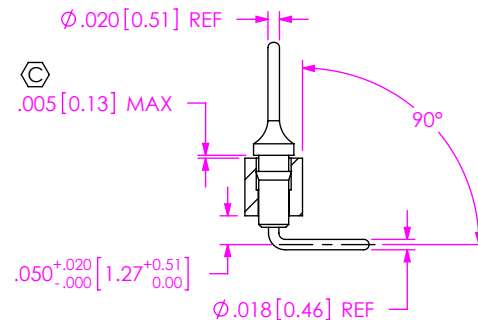

FIG 20
TERMINAL STYLE -N

PROPRIETARY NOTE
THIS DOCUMENT CONTAINS CONFIDENTIAL AND PROPRIETARY INFORMATION AND ALL DESIGN, MANUFACTURING, REPRODUCTION, USE, PATENT RIGHTS AND SALES RIGHTS ARE EXPRESSLY RESERVED BY SAMTEC, INC. THIS DOCUMENT SHALL NOT BE DISCLOSED, IN WHOLE OR PART, TO ANY UNAUTHORIZED PERSON OR ENTITY NOR REPRODUCED, TRANSFERRED OR INCORPORATED IN ANY OTHER PROJECT IN ANY MANNER WITHOUT THE EXPRESS WRITTEN CONSENT OF SAMTEC, INC.

DO NOT SCALE DRAWING

SHEET SCALE: 3:1



520 PARK EAST BLVD, NEW ALBANY, IN 47150
PHONE: 812-944-6733 FAX: 812-948-5047
e-Mail: info@SAMTEC.com code 55322

DESCRIPTION:
HIGH TEMP, TERMINAL STRIP ASSEMBLY

DWG. NO.
HTS-1XX-X-X-X-X-X

BY: L.W. 01/05/1984 SHEET 3 OF 3