

6 5 4 3 2 1

APPROVED: _____
 DATE: _____ TITLE: _____

Rev	AWO #	Description	Date	Appr
-		RELEASED	01/17/07	
A		UPDATE DRAWING	10/25/17	AY/NC

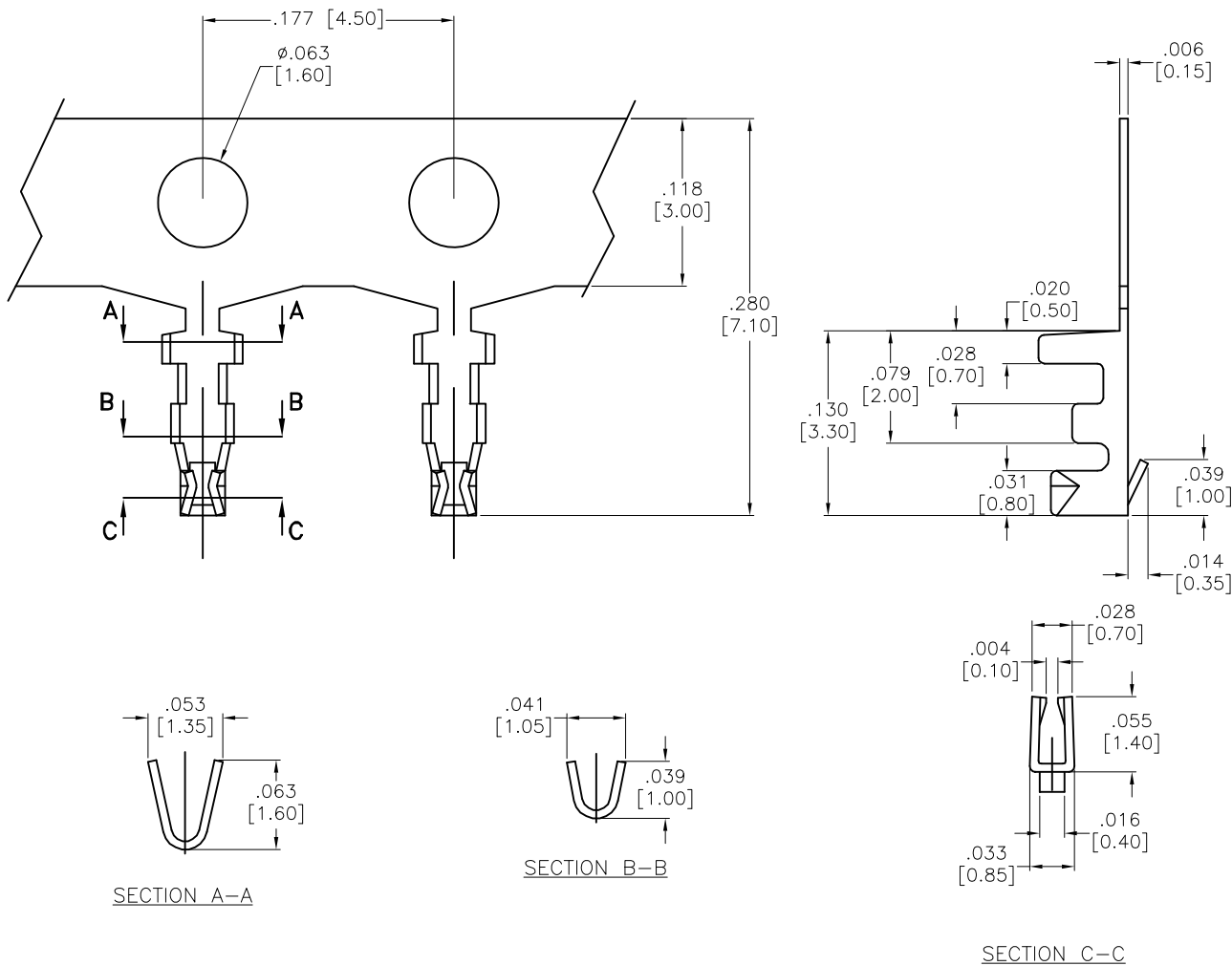

SPECIFICATIONS:
 Material: Phosphor Bronze 0.15mm Thickness
 Plating: Tin Plated
 Electrical:
 Current rating: 1 Amp max AC/DC
 Contact resistance: 20 mohms max.
 Insulation resistance: 100 Mohms min
 Dielectric withstanding voltage: 125 VAC for 1 minute
 Mechanical:
 Wire Range: 28-32 AWG.
 Packaging: 15,000 Pcs / Reel
 Environmental:
 Lead free, RoHS compliant.



APPROVALS		DATE
DRAWN	BW	01/17/07
CHECKED		
APPROVED		

ADAM TECH
 909 Rahway Avenue, Union, NJ 07083
 Phone: 908-687-5000 Fax: 908-687-5710

TITLE: 1.25mm TERMINAL

SIZE X	PART NO. 125CTB-R	REV. A
-----------	----------------------	-----------

REF: S00124T SCALE: NTS SHEET 1 OF 1