

N=Number of contacts

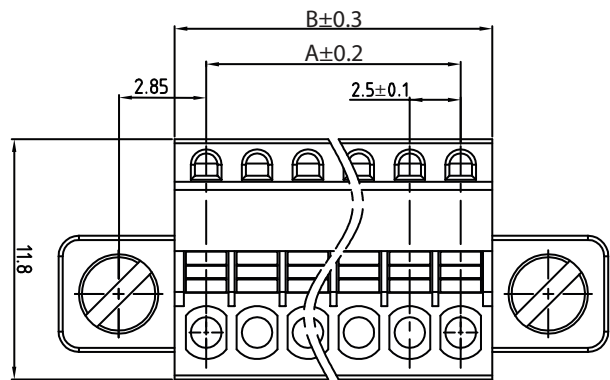
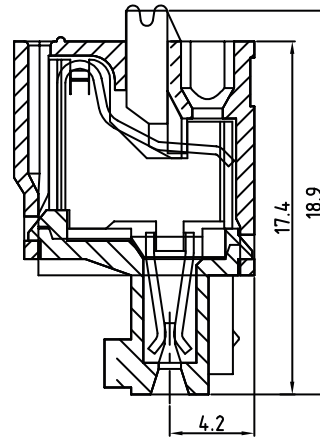

A	(N-1)X2.5
B	NX2.5+0.6

TECHNICAL CHARACTERISTICS

MATERIAL
 INSULATOR: PA 66
 FLAMMABILITY RATING: UL94-V0
 COLOR: GREEN
 CONTACT MATERIAL: COPPER ALLOY
 CONTACT TYPE: STAMPED
 CONTACT PLATING: TIN PLATED
 FLANGE SCREW: STEEL

ENVIRONMENTAL
 OPERATING TEMPERATURE: -40°C UP TO +105°C
 COMPLIANCE: LEAD FREE AND ROHS

ELECTRICAL
 CURRENT RATING: 12A
 WORKING VOLTAGE: 300V AC
 WITHSTANDING VOLTAGE: 2500 VAC/min
 CONTACT RESISTANCE: 20 mΩ max

STANDARD
 RoHS CERTIFIED E315414

MECHANICAL
 SOLID WIRE: 24-16 AWG / 0.205-1.31 MM²
 STRANDED WIRE: 24-16 AWG / 0.205-1.31 MM²

WIRE STRIP LENGTH: 6-8 MM
 PITCH: 2,5 MM

PACKAGING
 BOX

RoHS Compliant

G			
F			
E			
D			
C			
B	12-AUG-15	REMOVE SOLDER	AK
A	23-JUL-14	PDF	AS
REV	DATE	FILE	BY

PROJECTION:	
APPROVAL: FBr	

GENERAL TOLERANCE
.X = +/- 0.2
.XX = +/- 0.15
UNIT: MM
SCALE:
SHEET: 1/2
DRAW: AS

DESCRIPTION: SERIE 381 - VERTICAL CABLE ENTRY PLUG SCREWLESS	
WITH FLANGES - PITCH 2.5mm - WR-TBL	
WERI PART NO: 691 381 030 0XX	

SIZE
A4

1

2

3

4

5

Cautions and Warnings:

This electronic component is designed and developed with the intention for use in general electronics equipments.

Before incorporating the components into any equipments in the field such as aerospace, aviation, nuclear control, submarine, transportation, (automotive control, train control, ship control), transportation signal, disaster prevention, medical, public information network etc. where higher safety and reliability are especially required or if there is possibility of direct damage or injury to human body, Würth Elektronik must be asked for a written approval.

In addition, even electronic component in general electronic equipments, when used in electrical circuits that require high safety, reliability functions or performance, the sufficient reliability evaluation-check for the safety must be performed before by the user before usage.

A

B

C

RoHS Compliant

G				PROJECTION: 	GENERAL TOLERANCE .X = +/- 0.2 .XX = +/- 0.15		
F							
E							
D							
C				APPROVAL: JC	UNIT: MM	DESCRIPTION: DISCLAIMER	SIZE A4
B					SCALE:		
A	10-SEP-14	PDF	QL		SHEET: 2/2	WERI PART NO: DISCLAIMER	
REV	DATE	FILE	BY		DRAW: QL		

D