

THIS DRAWING IS UNPUBLISHED. RELEASED FOR PUBLICATION
 © COPYRIGHT - By - ALL RIGHTS RESERVED.

LOC	DIST	REVISIONS			
P	LTR	DESCRIPTION	DATE	DWN	APVD
AD	00	K1 REVISED PER ECO-11-004820	11MAR11	RK	HMR

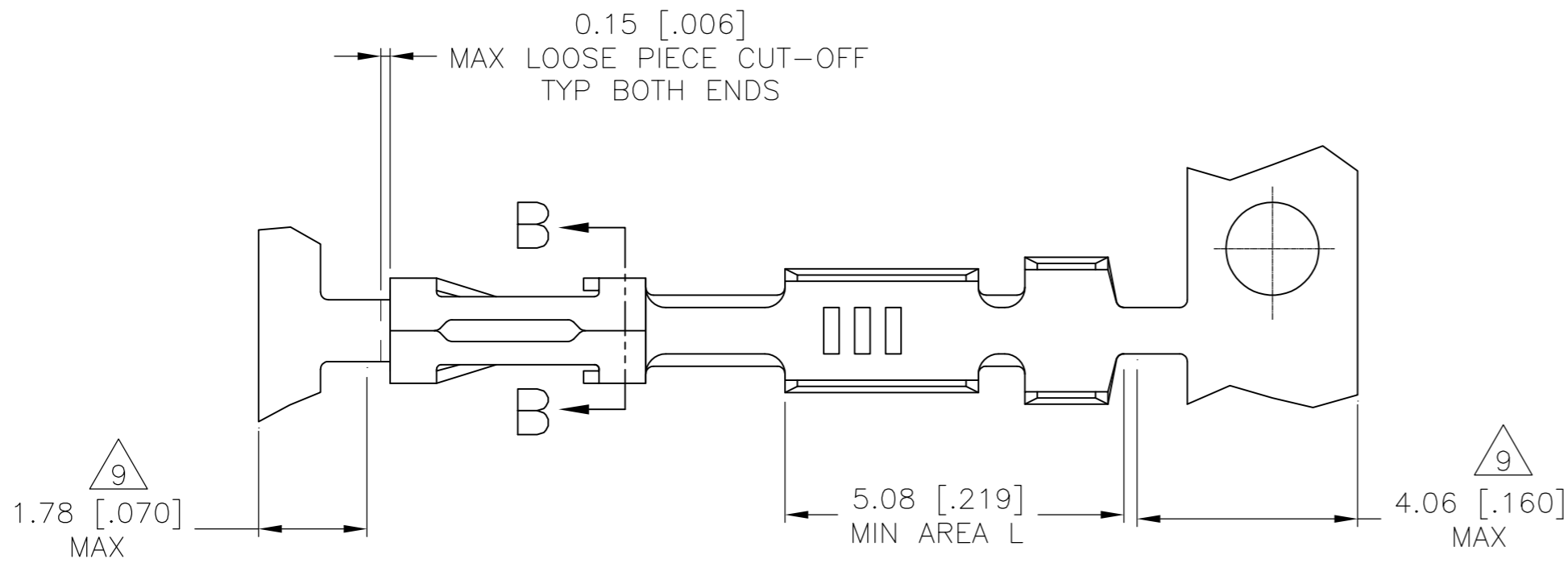

- 1 REELED PER MINI-APPLICATOR.
- 2 0.00076[.000030] GOLD ON CONTACT AREA, GOLD FLASH ON THE REMAINDER, OVER 0.00127[.000050] NICKEL.
- 3 0.00127[.000050]-0.00381[.000150] PREPLATED BRIGHT TIN.
- 4 0.00038[.000015] GOLD IN CONTACT AREA, 0.00254[.000100]-0.00508[.000200] BRIGHT TIN-LEAD IN AREA L, ALL OVER 0.00127[.000050] NICKEL.
- 5 0.00076[.000030] GOLD IN CONTACT AREA, 0.00254[.000100]-0.00508[.000200] BRIGHT TIN-LEAD IN AREA L, ALL OVER 0.00127[.000050] NICKEL.
- 6 SHEARED EDGES PERMITTED TO BE UNPLATED.
- 7 POINT OF MEASUREMENT FOR PLATING THICKNESS (INSIDE BEAMS).
- 8 0.00038[.000015] GOLD ON THE CONTACT AREA, GOLD FLASH ON THE REMAINDER, ALL OVER 0.00127[.000050] NICKEL.
- 9 GOLD LATING NOT REQUIRED IN THIS AREA.

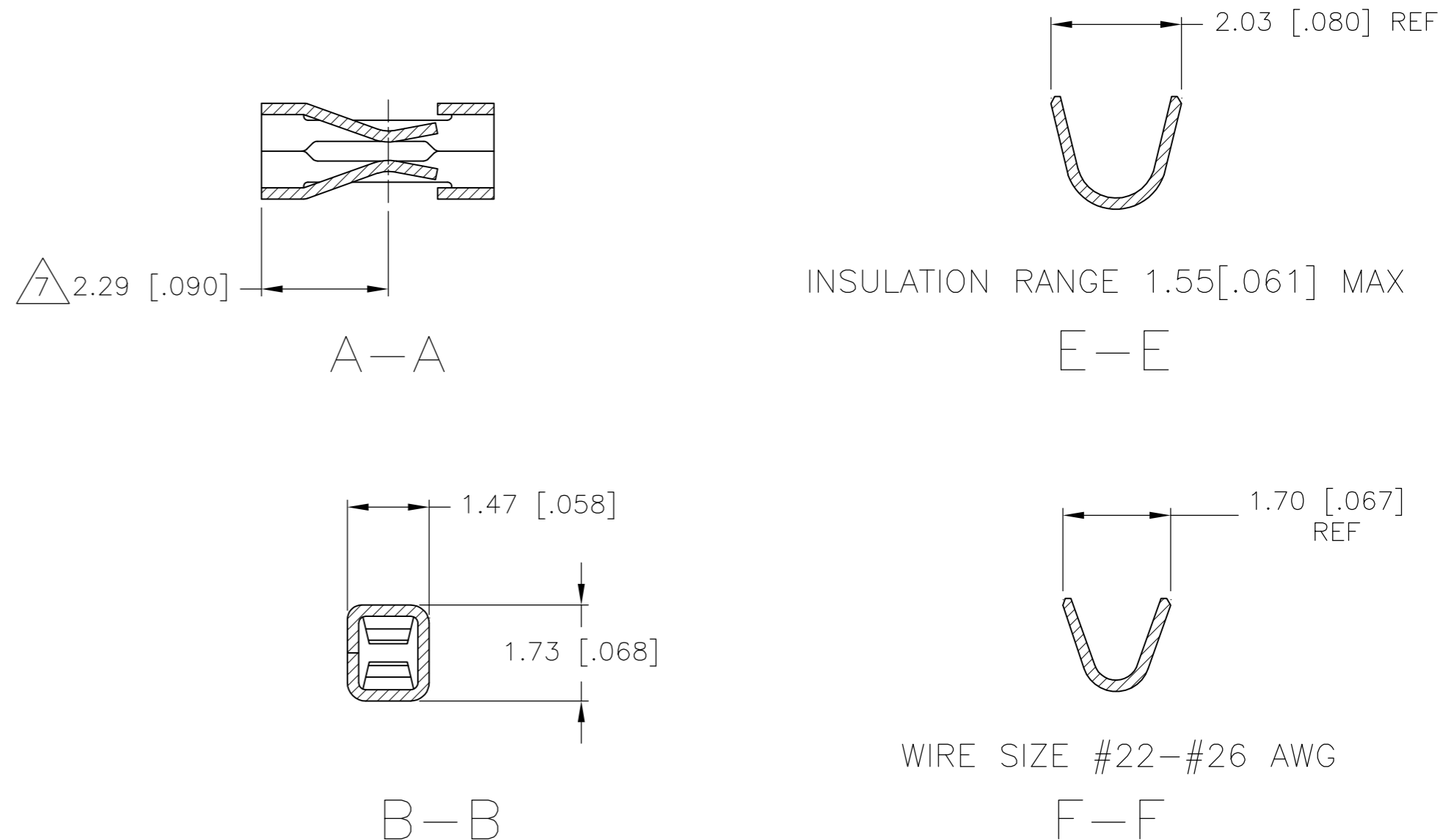
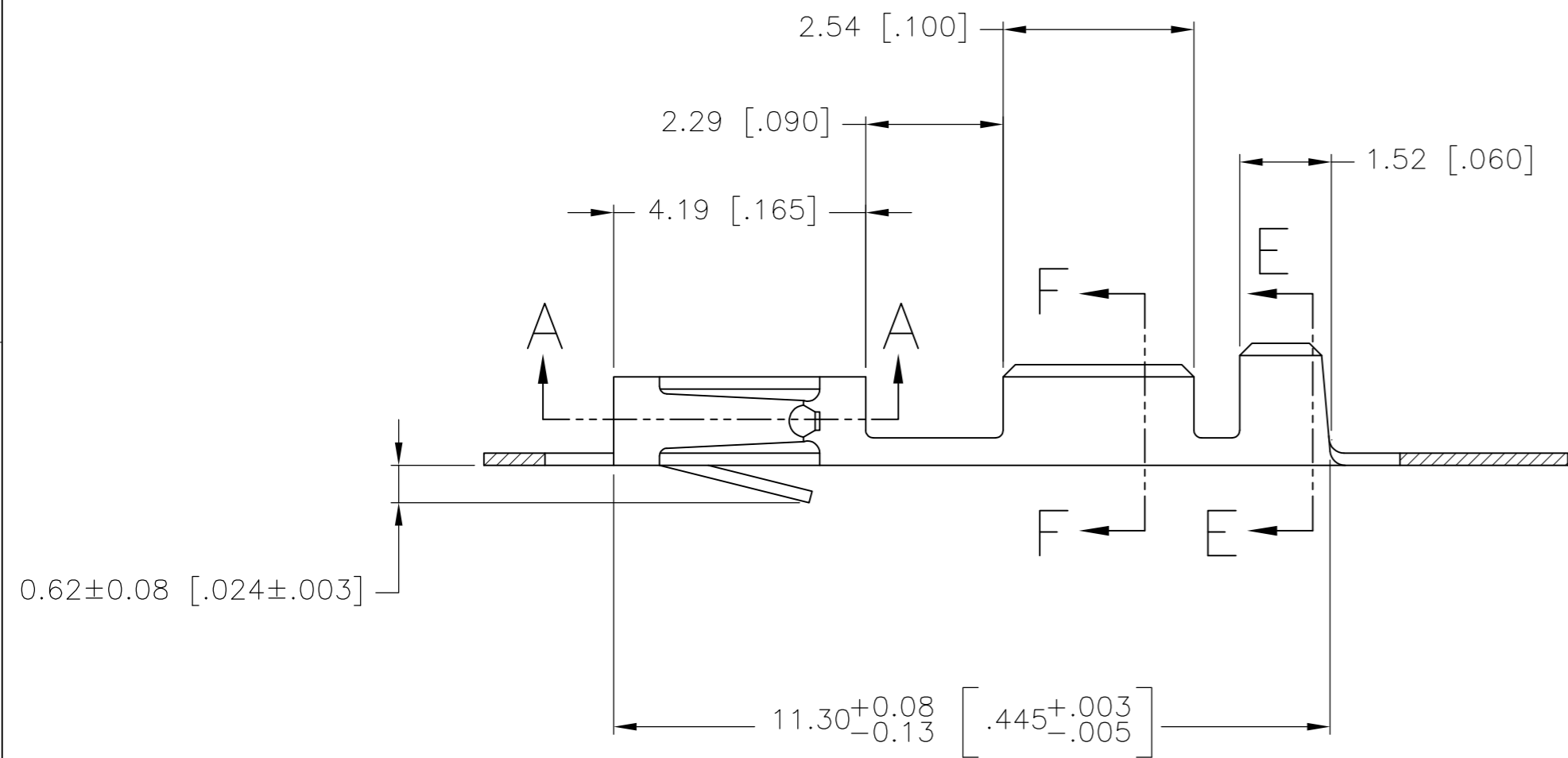

	8	87809-6
OBSOLETE	5 6	87809-5
OBSOLETE	4 6	87809-4
	3	87809-2
	2	87809-1
	FINISH	PART NUMBER

THIS DRAWING IS A CONTROLLED DOCUMENT.		DWN E. BRANDBERG 20FEB96	TE TE Connectivity	
DIMENSIONS: mm [INCHES]		CHK S. SHUEY 20FEB96		
TOLERANCES UNLESS OTHERWISE SPECIFIED:		APVD S. SHUEY 20FEB96	NAME CONTACT, FEMALE, MOD V, CRIMP SNAP-IN	
0 PLC ± -	1 PLC ± -	PRODUCT SPEC 108-25019	SIZE A2	CAGE CODE -
2 PLC ± 0.13[.005]	3 PLC ± -	APPLICATION SPEC 114-25003	DRAWING NO C=87809	RESTRICTED TO -
4 PLC ± -	ANGLES ± -	WEIGHT -	SCALE 10:1	SHEET 1 OF 1
MATERIAL PHOS BRONZE 0.20[.008] THK	FINISH AS NOTED	CUSTOMER DRAWING	REV K1	