



ULTRA LOW NOISE, MEDIUM CURRENT

D-PHEMT Transistor

SAV-331+

Mini-Circuits

50Ω 10-4000 MHz

THE BIG DEAL

- Low Noise Figure, 0.5 dB typ. at 300 MHz
- Gain, 24.1 dB typ. at 300 MHz
- High Output IP3, +32.3 dBm typ. at 300 MHz
- Output Power at 1dB comp., +19.6 dBm typ. at 300 MHz
- Low Current, 60mA
- External biasing and matching required



Generic photo used for illustration purposes only

CASE STYLE: MMM1362

+RoHS Compliant

The +Suffix identifies RoHS Compliance. See our web site for RoHS Compliance methodologies and qualifications

APPLICATIONS

- Cellular
- ISM
- GSM
- WCDMA
- WiMax
- WLAN
- UNII and HIPERLAN

PRODUCT OVERVIEW

Mini-Circuits' SAV-331+ is a MMIC D-PHEMT transistor with an operating frequency range from 10 to 4000 MHz. This model combines high gain with extremely low noise figure, resulting in lower overall system noise. Low NF and IP3 performance make it an ideal choice for sensitive receivers in communications systems. Manufactured using highly repeatable D-PHEMT* technology, the unit comes housed in a tiny 4-lead SOT-343 package. This model requires external biasing and matching.

SIMPLIFIED SCHEMATIC AND PIN DESCRIPTION

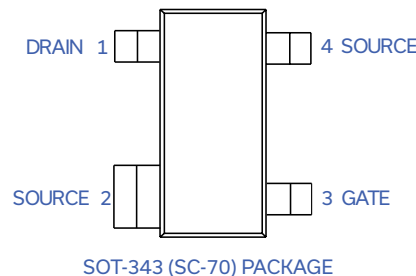
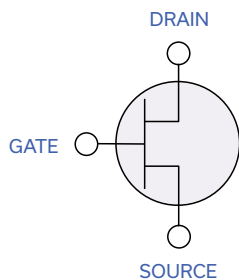

Function	Pin Number	Description
Source	2 & 4	Source terminal, normally connected to ground
Gate	3	Gate used for RF Input
Drain	1	Drain used for RF output

* Depletion mode Pseudomorphic High Electron Mobility Transistor.

REV. B
ECO-010314
SAV-331+
RS/CP/AM
211022





ULTRA LOW NOISE, MEDIUM CURRENT

D-PHEMT Transistor

SAV-331+

Mini-Circuits

ELECTRICAL SPECIFICATIONS AT $T_{AMB}=25^{\circ}\text{C}$, FREQUENCY 10 TO 4000 MHZ

Symbol	Parameter	Condition	Min.	Typ.	Max.	Units
DC Specifications						
V_{GS}	Operational Gate Voltage	$V_{DS}=4\text{V}, I_{DS}=60\text{ mA}$	-0.96	-0.69	-0.51	V
V_P	Pinch-off Voltage	$V_{DS}=1.5\text{ V}, I_{DS}=10\% \text{ of } I_{DSS}$		-0.81		V
I_{DSS}	Saturated Drain Current	$V_{DS}=4\text{V}, V_{GS}=0\text{ V}$		228		μA
G_M	Transconductance	$V_{DS}=4\text{V}, G_m=\Delta I_{DS}/\Delta V_P$	—	282	—	mS
I_{GDO}	Gate to Drain Leakage Current	$V_{GD}=5\text{V}$			1000	μA
I_{GSS}	Gate leakage Current	$V_{GD}=V_{GS}=-4\text{V}$			600	μA
Specifications, $Z_0=50\text{ Ohms}$ (Figure 1)*						
NF	Noise Figure	$V_{DS}=4\text{V}, I_{DS}=60\text{ mA}$		0.9		dB
			f=40 MHz	0.9		
			f=300 MHz	0.5		
			f=900 MHz	0.4	0.8	
			f=2000 MHz	0.5		
			f=4000 MHz	0.9		
Gain	Gain	$V_{DS}=4\text{V}, I_{DS}=60\text{ mA}$		24.6		dB
			f=40 MHz	24.6		
			f=300 MHz	24.1		
			f=900 MHz	21.3	18.3	
			f=2000 MHz	13.9	16.6	
			f=4000 MHz	11.5		
OIP3	Output IP3	$V_{DS}=4\text{V}, I_{DS}=60\text{ mA}$		30.9		dBm
			f=40 MHz	30.9		
			f=300 MHz	32.3		
			f=900 MHz	33.5		
			f=2000 MHz	35.5		
			f=4000 MHz	38.7		
P1dB	Power output at 1 dB Compression	$V_{DS}=4\text{V}, I_{DS}=60\text{ mA}$		19.1		dBm
			f=40 MHz	19.1		
			f=300 MHz	19.6		
			f=900 MHz	18.0	20.2	
			f=2000 MHz	18.9	21.1	
			f=4000 MHz		21.8	
Θ_{JC}	Thermal Resistance			109		$^{\circ}\text{C}/\text{W}$

* Tested on Mini-Circuits TB-471+ test board

MAXIMUM RATINGS⁽¹⁾

Symbol	Parameter	Max.	Units
V_{DS}	Drain-Source Voltage ²	5	V
V_{GS}	Gate-Source Voltage ²	-5	V
V_{GD}	Gate-Drain Voltage ²	-5	V
I_{DS}	Drain Current ²	149	mA
P_{DISS}	Total Dissipated Power	400	mW
P_{IN}	RF Input Power	20	dBm
T_{CH}	Channel Temperature	150	$^{\circ}\text{C}$
T_{OP}	Operating Temperature	-40 to 85	$^{\circ}\text{C}$
T_{STD}	Storage Temperature	-65 to 150	$^{\circ}\text{C}$

(1) Operation of this device above any one of these parameters may cause permanent damage.

(2) Assumes DC quiescent conditions, $V_{GS} = -0.51\text{ V}$, $V_{DS} = 4\text{ V}$.





CHARACTERIZATION TEST CIRCUIT

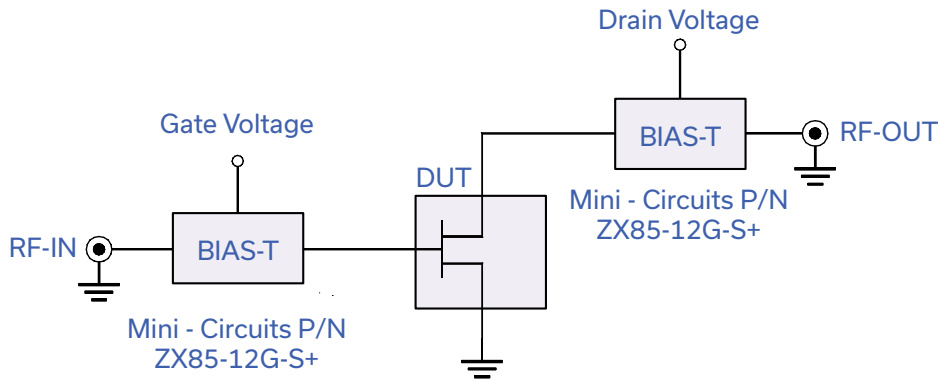

Fig 1. Block Diagram of Test Circuit used for characterization. (DUT soldered on Mini-Circuits Test Board TB-471+)

Gain, Output power at 1dB compression (P1 dB) and output IP3 (OIP3) are measured using R&S Network Analyzer ZVA-24. Noise Figure measured using keysight PNA-X.

Conditions:

1. Drain voltage (with reference to source, VDS)= 4V as shown.
2. Gate Voltage (with reference to source, VGS) is set to obtain desired Drain-Source current (IDS) as shown in graphs or specification table.
3. Gain: Pin= -25dBm
4. Output IP3 (OIP3): Two tones, spaced 1 MHz apart, 0 dBm/tone at output.
5. No external matching components used.

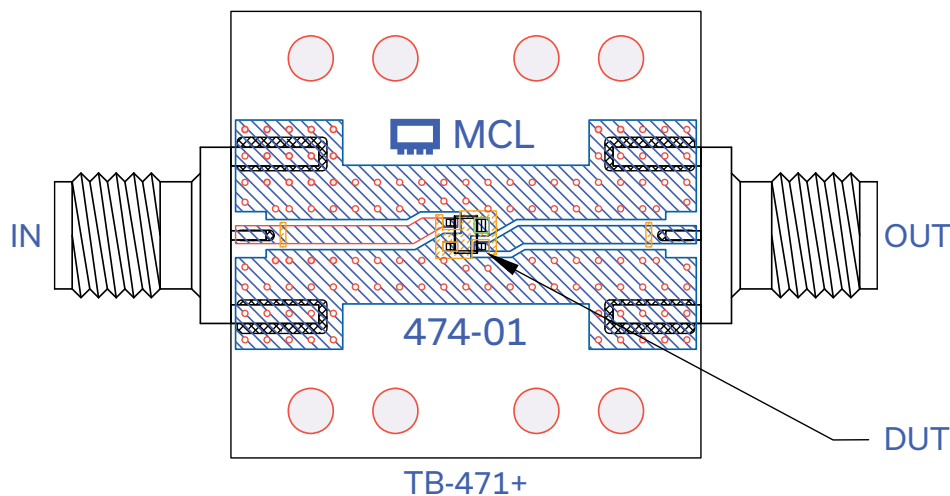
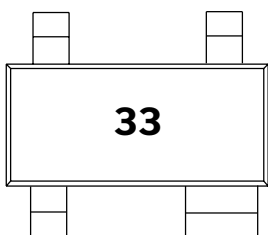

Fig 2. Test Board used for characterization, Mini-Circuits P/N TB-471+ (Material: Rogers 4350, Thickness: 0.02")

PRODUCT MARKING





ULTRA LOW NOISE, MEDIUM CURRENT

D-PHEMT Transistor

SAV-331+

Mini-Circuits

ADDITIONAL DETAILED TECHNICAL INFORMATION IS AVAILABLE ON OUR DASH BOARD. TO ACCESS [CLICK HERE](#)

Performance Data	Data Table
	Swept Graphs
	S-Parameter (S2P Files) Data Set (.zip file)
Case Style	MMM1362 Plastic molded SOT-343 (SC-70) style package, lead finish: matte-tin
Tape & Reel Standard quantities available on reel	F90 7" reels with 20, 50, 100, 200, 500,1K,2K or 3K devices
Suggested Layout for PCB Design	PL-300
Evaluation Board	TB-471+
Environmental Ratings	ENV08T2

ESD RATING

Human Body Model (HBM): Class 0 (<250V) in accordance with ANSI/ESD STM 5.1 - 2001

Machine Model (MM): Class M1 (40 V) in accordance with ANSI/ESD STM 5.2 - 1999

MSL RATING

Moisture Sensitivity: MSL1 in accordance with IPC/JEDEC J-STD-020D

MSL TEST FLOW CHART

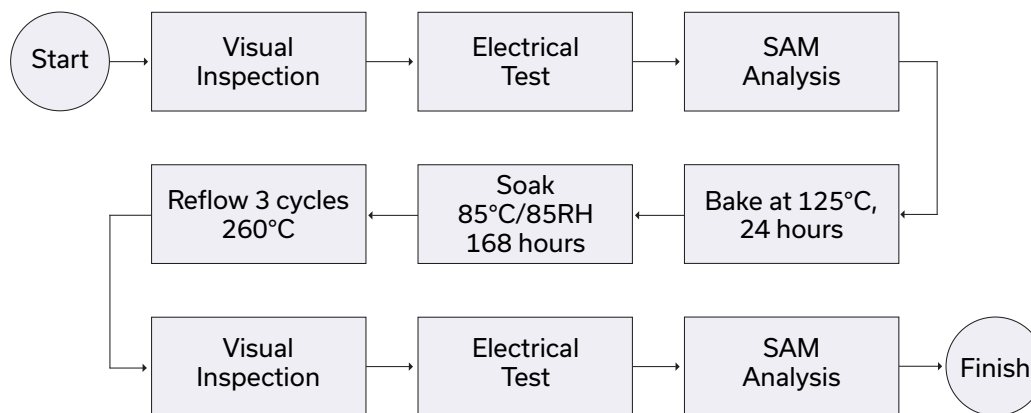

- NOTES**
- A. Performance and quality attributes and conditions not expressly stated in this specification document are intended to be excluded and do not form a part of this specification document.
 - B. Electrical specifications and performance data contained in this specification document are based on Mini-Circuit's applicable established test performance criteria and measurement instructions.
 - C. The parts covered by this specification document are subject to Mini-Circuits standard limited warranty and terms and conditions (collectively, "Standard Terms"); Purchasers of this part are entitled to the rights and benefits contained therein. For a full statement of the standard. Terms and the exclusive rights and remedies thereunder, please visit Mini-Circuits' website at www.minicircuits.com/MCLStore/terms.jsp

