

1

2

3

4

5

RoHS Compliant

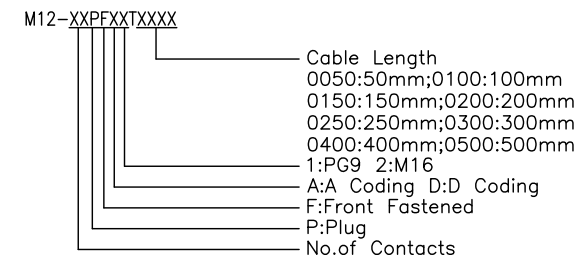
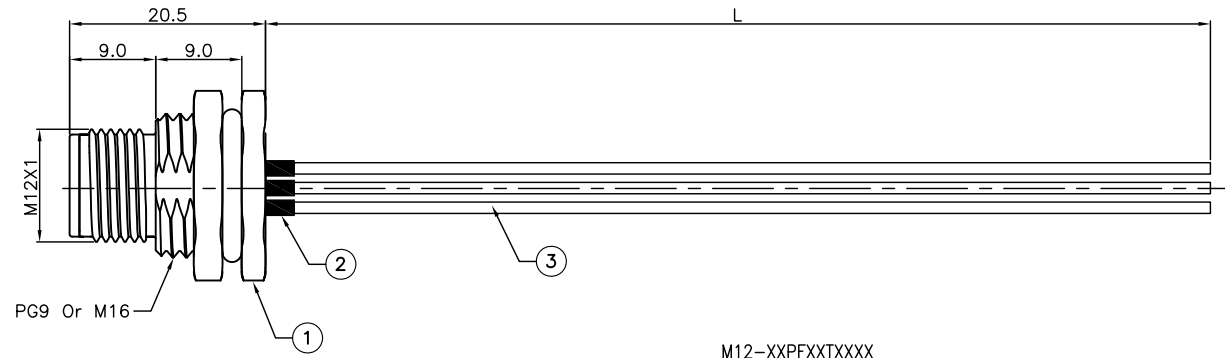
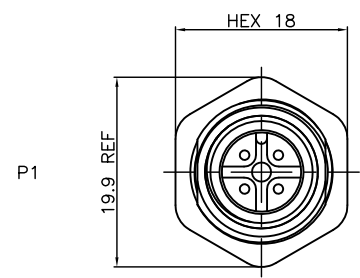

A Coding						
D Coding						

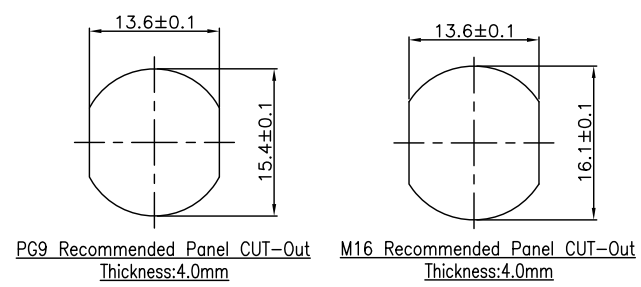

ITEM	PART NO.	DESCRIPTION	Q'TY
1	M12-XXP-FX-PMX	M12 Plug Front Fastened Solder Type	1
2	825-H.S-XX-BK	Heat Shrink Tube Color:Black	A/R
3	809-TPEXXTSW-XX	TPE XXAWG Wire Color:XX	A/R

F				DRAWN: Andrew	GENERAL TOLERANCE:	
E					CHECKED: Bill He	.X=±0.50
D				APPROVAL: Andrew		.XX=±0.30
C					A	01-Jul-2022
B				REV		DATE
A				BY		

OST
ON-SHORE TECHNOLOGY, INC.

DESCRIPTION:
M12 PLUG FRONT FASTENED WIRE HARNESS

PART NO:
M12-XXPFXXTXXXX

UNIT: MM
SCALE: 1:1
SHEET: 1/2
PROJECTION:

A

B

C

D

1

2

3

4

5

RoHS Compliant

2P PIN OUT:

P1	
1	Black
3	Brown

ITEM	PART NO.	DESCRIPTION	Q'TY
1	M12-02P-FX-PMX	M12 2Pin Plug Front Fastened Solder Type	1
2	825-H.S-XX-BK	Heat Shrink Tube Color:Black	A/R
3	809-TPE22TSW-XX	TPE 22AWG Wire Color:XX	A/R

3P PIN OUT:

P1	
1	Black
3	Brown
4	Red

ITEM	PART NO.	DESCRIPTION	Q'TY
1	M12-03P-FX-PMX	M12 3Pin Plug Front Fastened Solder Type	1
2	825-H.S-XX-BK	Heat Shrink Tube Color:Black	A/R
3	809-TPE22TSW-XX	TPE 22AWG Wire Color:XX	A/R

4P PIN OUT:

P1	
1	Black
2	White
3	Brown
4	Red

ITEM	PART NO.	DESCRIPTION	Q'TY
1	M12-04P-FX-PMX	M12 4Pin Plug Front Fastened Solder Type	1
2	825-H.S-XX-BK	Heat Shrink Tube Color:Black	A/R
3	809-TPE22TSW-XX	TPE 22AWG Wire Color:XX	A/R

5P PIN OUT:

P1	
1	Black
2	White
3	Brown
4	Red
5	Yellow

ITEM	PART NO.	DESCRIPTION	Q'TY
1	M12-05P-FX-PMX	M12 5Pin Plug Front Fastened Solder Type	1
2	825-H.S-XX-BK	Heat Shrink Tube Color:Black	A/R
3	809-TPE22TSW-XX	TPE 22AWG Wire Color:XX	A/R

6P PIN OUT:

P1	
1	Black
2	White
3	Brown
4	Red
5	Yellow
6	Blue

ITEM	PART NO.	DESCRIPTION	Q'TY
1	M12-06P-FX-PMX	M12 6Pin Plug Front Fastened Solder Type	1
2	825-H.S-XX-BK	Heat Shrink Tube Color:Black	A/R
3	809-TPE24TSW-XX	TPE 24AWG Wire Color:XX	A/R

7P PIN OUT:

P1	
1	Black
2	White
3	Brown
4	Red
5	Yellow
6	Blue
7	Orange

ITEM	PART NO.	DESCRIPTION	Q'TY
1	M12-07P-FX-PMX	M12 7Pin Plug Front Fastened Solder Type	1
2	825-H.S-XX-BK	Heat Shrink Tube Color:Black	A/R
3	809-TPE24TSW-XX	TPE 24AWG Wire Color:XX	A/R

8P PIN OUT:

P1	
1	Black
2	White
3	Brown
4	Red
5	Yellow
6	Blue
7	Orange
8	Green

ITEM	PART NO.	DESCRIPTION	Q'TY
1	M12-08P-FX-PMX	M12 8Pin Plug Front Fastened Solder Type	1
2	825-H.S-XX-BK	Heat Shrink Tube Color:Black	A/R
3	809-TPE24TSW-XX	TPE 24AWG Wire Color:XX	A/R

9P PIN OUT:

P1	
1	Black
2	White
3	Brown
4	Red
5	Yellow
6	Blue
7	Orange
8	Green
9	Purple

ITEM	PART NO.	DESCRIPTION	Q'TY
1	M12-09P-FX-PMX	M12 9Pin Plug Front Fastened Solder Type	1
2	825-H.S-XX-BK	Heat Shrink Tube Color:Black	A/R
3	809-TPE26TSW-XX	TPE 26AWG Wire Color:XX	A/R

10P PIN OUT:

P1	
1	Black
2	White
3	Brown
4	Red
5	Yellow
6	Blue
7	Orange
8	Green
9	Purple
10	Grey

ITEM	PART NO.	DESCRIPTION	Q'TY
1	M12-10P-FX-PMX	M12 10Pin Plug Front Fastened Solder Type	1
2	825-H.S-XX-BK	Heat Shrink Tube Color:Black	A/R
3	809-TPE26TSW-XX	TPE 26AWG Wire Color:XX	A/R

11P PIN OUT:

P1	
1	Black
2	White
3	Brown
4	Red
5	Yellow
6	Blue
7	Orange
8	Green
9	Purple
10	Grey
11	Pink

ITEM	PART NO.	DESCRIPTION	Q'TY
1	M12-11P-FX-PMX	M12 11Pin Plug Front Fastened Solder Type	1
2	825-H.S-XX-BK	Heat Shrink Tube Color:Black	A/R
3	809-TPE26TSW-XX	TPE 26AWG Wire Color:XX	A/R

12P PIN OUT:

P1	
1	Black
2	White
3	Brown
4	Red
5	Yellow
6	Blue
7	Orange
8	Green
9	Purple
10	Grey
11	Pink
12	Light Green

ITEM	PART NO.	DESCRIPTION	Q'TY
1	M12-12P-FX-PMX	M12 12Pin Plug Front Fastened Solder Type	1
2	825-H.S-XX-BK	Heat Shrink Tube Color:Black	A/R
3	809-TPE26TSW-XX	TPE 26AWG Wire Color:XX	A/R

F				DRAWN: Andrew	GENERAL TOLERANCE:		 ON-SHORE TECHNOLOGY, INC.
E					CHECKED: Bill He	.X=±0.50	
D				APPROVAL: Bill He		UNIT: MM	
C					A	SCALE: 1:1	
B				REV		SHEET: 2/2	
A	01-Jul-2022		Andrew		BY	PROJECTION: 