

FLH-CT-P-1-02 APPLICATOR

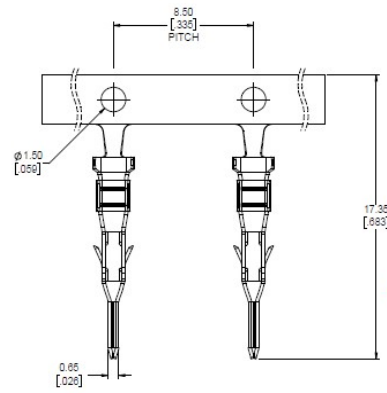

PIN CONTACT FLH-PC136-1-T01

REVISIONS			
REV	DESCRIPTION, ECN, EAR NO.	DATE	APP'D
A	PROPOSAL DWG. NEW PER EAR 15148	JUN30/22	S.M



FLH-CT-0-02 CRIMP MACHINE WITH APPLICATOR

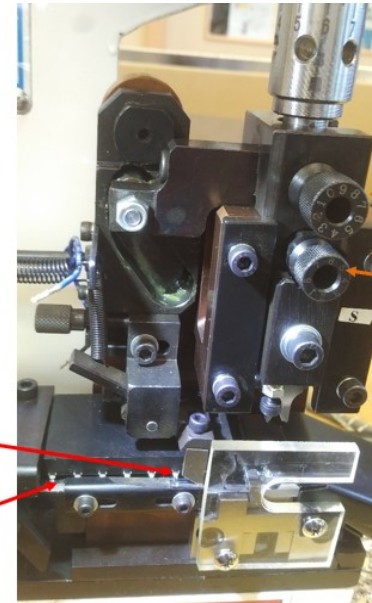

Wire crimp adjuster
Pull and rotate to make adjustments

Insulation crimp adjuster
Pull and rotate to make adjustments

IMPORTANT
Only wire and insulator adjustments are made, and nothing else

NOTES:

1. CRIMP PIN APPLICATOR SHOULD BE USED WITH FLH-CT-0-02 CRIMP MACHINE OR ADOPTED TO OTHER CRIMPING MACHINES
2. CRIMP TOOL IS INCLUDED WITH THE APPLICATOR
3. PIN CONTACT, FLH-PC136-T01 IN REEL ONLY TO BE USED WITH THIS APPLICATOR
4. PLEASE REFER TO APPLICATION SPECIFICATION NO. S 6147C
5. FOR ORDERING INFORMATION PLEASE CONTACT THE AMPHENOL REPRESENTATIVE



AMPHENOL PART No. FLH-CT-P-1-02

UNLESS SPECIFIED OTHERWISE	DRAWN	S.MUGAN	FEB04/21
PRIMARY UNITS MILLIMETERS	CHECKED		
SECONDARY REFERENCE IN PARENTHESES	M.E. APP'D		
GENERAL TOLERANCES	Q.A. APP'D		
1 DECIMAL PLACE	DWG APPR.		
2 DECIMAL PLACES	ENG. REL. NO.		
3 DECIMAL PLACES	REF.		
ANGULAR DEGREES	THIRD ANGLE PROJECTION		

Amphenol Canada Corp.
Commercial Products

FLH PIN CRIMP APPLICATOR
SEMI-AUTOMATIC

DWG. NO.	REV
P-FLH-CT-P-1-02	A
CODE ID NO. 03554	DWG SIZE: X
SCALE: 5:1	SHEET 1 OF 1