

LOC		DIST		REVISIONS			
P	LTR	DESCRIPTION	DATE	DN	APVD		
C		REVISED PER ECO-12-016930	05OCT12	KH	SM		
C1		ECR-12-016748	30AUG13	M.T	D.Z		

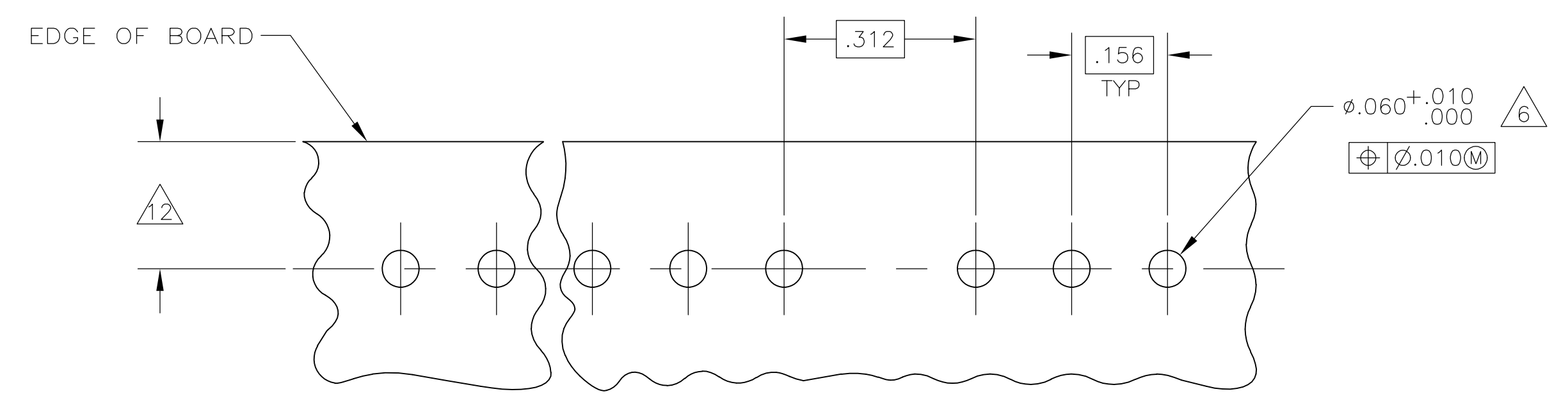
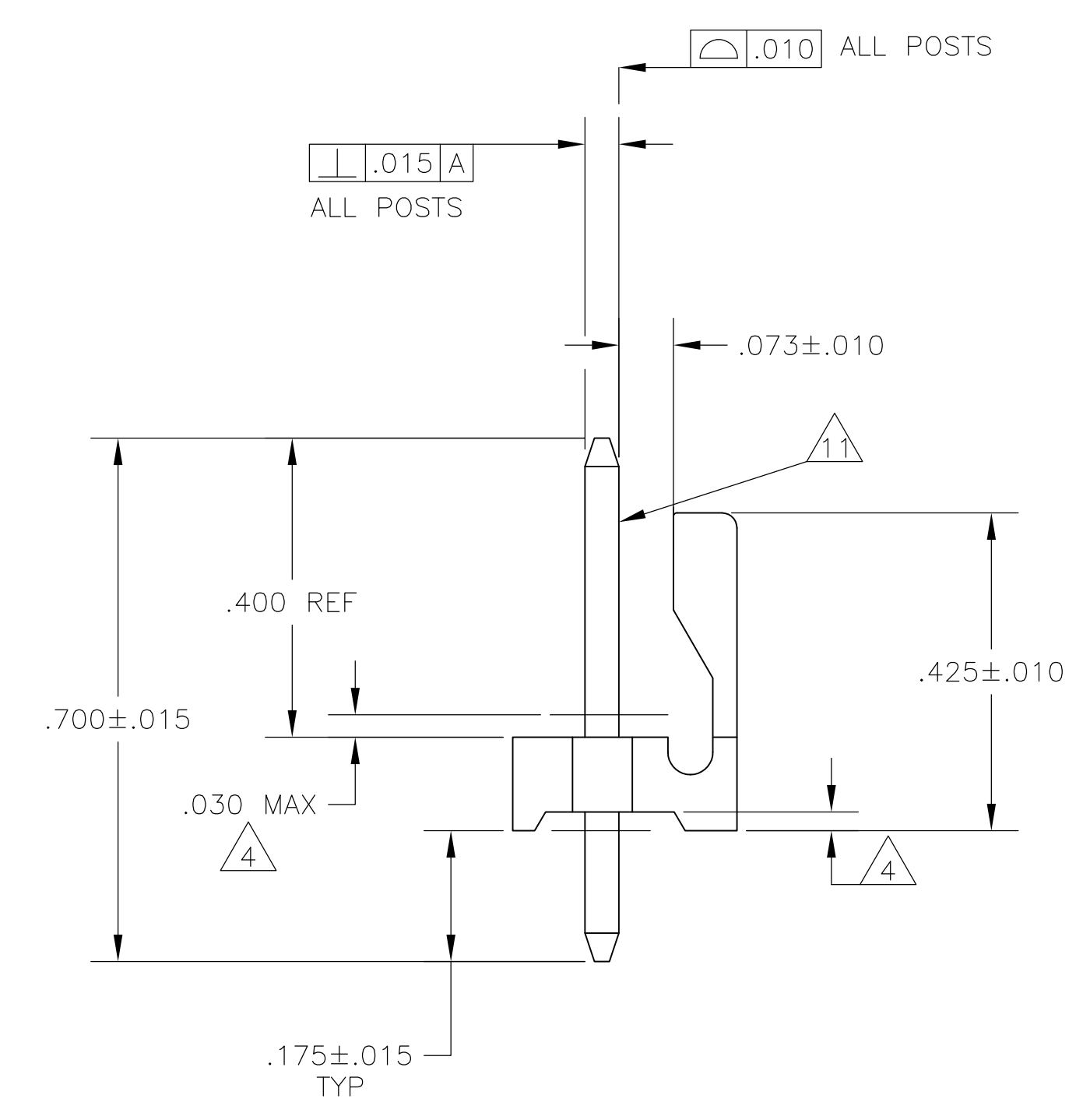
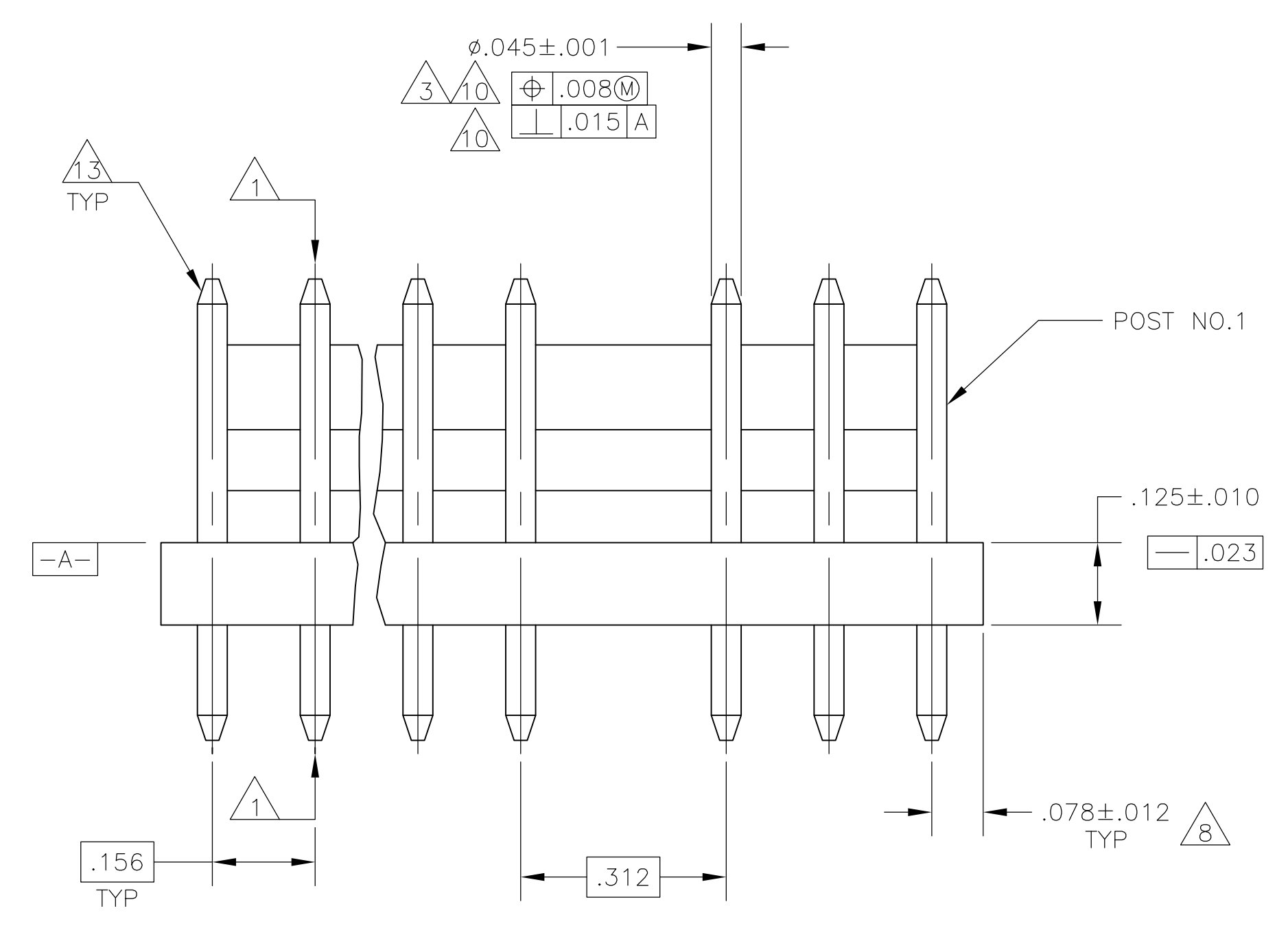
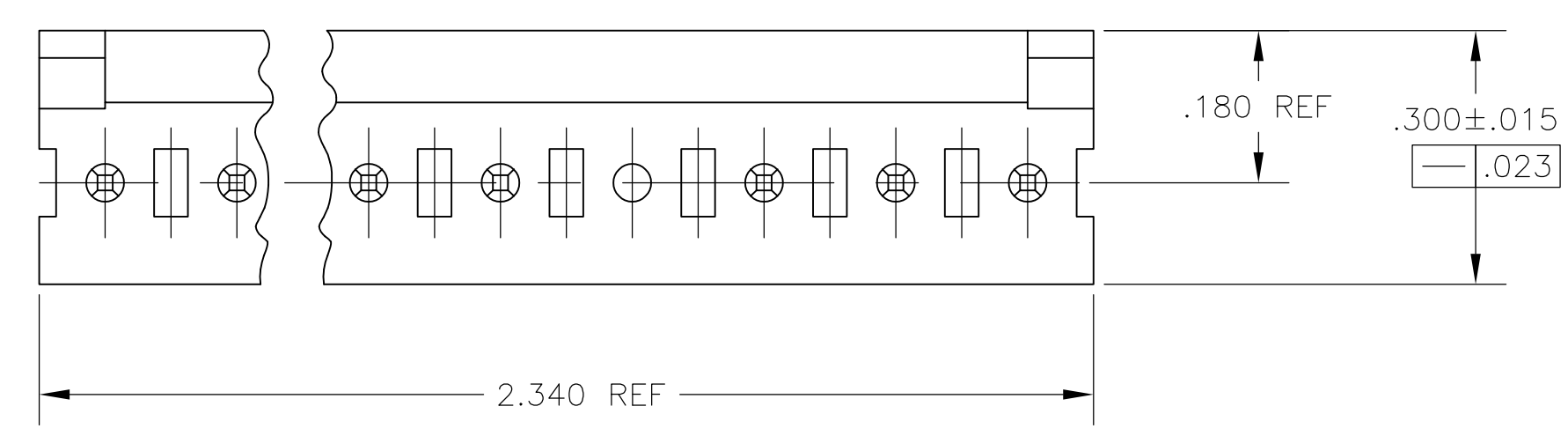

RECOMMENDED MOUNTING HOLE PATTERN FOR .109±.016 THICK P.C. BOARD

- 1 POST TO WITHSTAND 13 NEWTONS (3LBS.) MIN. AXIAL FORCE IN BOTH DIRECTIONS SHOWN WITHOUT DISLODGING.
- 2 TOLERANCES APPLY TO SOLDER SIDE OF BOARD.
- 3 MEASURED AT SURFACE -A-
- 4 PLASTIC FLASH PERMITTED IN THIS AREA.
- 5 PARTS COMPLY WITH AMP SOLDERABILITY SPEC. NO. 109-11-2.
- 6 ONE HOLE MAY BE UNDERSIZED (.051/.046 DIA.) FOR ASSEMBLY RETENTION DURING WAVE SOLDERING.
- 7 MATERIAL: HEADER-THERMOPLASTIC POLYESTER GLASS-FILLED 94V-0(NATURAL) POST-COPPER ALLOY (TIN PLATED)
- 8 COORDINATE DIMENSION APPLIES FROM CENTER OF ACTUAL FEATURE.
- 9 PLASTIC BURRS CAUSED BY CUT-OFF TOOLING ARE PERMITTED WITHIN THE MAXIMUM TOLERANCE ENVELOPE.
- 10 POST TO BE MEASURED WHEN STRIP IS HELD FLAT.
- 11 POST MUST WITHSTAND TWO 90° BENDS AGAINST EXTRUSION WITHOUT BREAKING.
- 12 DIMENSION SHOULD BE .175 MIN WHEN MATING WITH A MTA 156 CONNECTOR ASSEMBLY OR A SL-156 CONNECTOR ASSEMBLY.
- 13 PIN BURR OF .005 MAX. VERTICAL AND .003 MAX. HORIZONTAL PERMITTED AT POST TIPS ON BOTH ENDS.

IN	MM	IN	MM
.060	1.52		
.051	1.30	2.340	59.44
.046	1.17	.750	19.05
.045	1.14	.450	11.43
.030	0.76	.425	10.80
.023	0.58	.312	7.92
.015	0.38	.300	7.62
.012	0.30	.180	4.57
.010	0.25	.175	4.45
.008	0.20	.156	3.96
.005	0.13	.125	3.18
.003	0.08	.078	1.98
.001	0.03	.073	1.85
.000	0.00	.063	1.60
IN	MM	IN	MM

CONVERSION TABLE

4	644999-1
POST NUMBER OMITTED	PART NUMBER

THIS DRAWING IS A CONTROLLED DOCUMENT.

DIN B LEWIS 18AUG96
 CLK R SWING 18AUG96
 APVD D CLARK 18AUG96

NAME: MTA-156 HEADER ASSEMBLY, FRICTION LOCK, STRAIGHT, .045 ROUND POST, TIN PLATED, 15 POSITION, OMITTED POST

PRODUCT SPEC: APPLICATION SPEC

SIZE: A1
 CAGE CODE: 644999
 DRAWING NO: 644999

WEIGHT: --
 CUSTOMER DRAWING

SCALE: 5:1
 SHEET: 1 OF 1
 REV: C1