

RO3075E-1

345.0 MHz
SAW Resonator

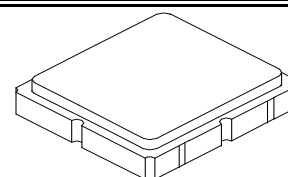

SM3030-6 Case
3.0 X 3.0

- **Ideal for 345 MHz Automotive-Keyless-Entry Transmitters**
- **Very Low Series Resistance**
- **Quartz Stability**
- **Complies with Directive 2002/95/EC (RoHS)**
- **Tape and Reel Standard per ANSI/EIA-481**
- **Moisture Sensitivity Level: 1**

The RO3075E-1 is a true one-port, surface-acoustic-wave (SAW) resonator in a surface-mount, ceramic case. It provides reliable, fundamental-mode, quartz frequency stabilization of fixed frequency transmitters operating at 345 MHz. The RO3075E-1 is designed for wireless remote control and security transmitters operating in the USA under FCC Part 15.

Absolute Maximum Ratings

Rating	Value	Units
Input Power Level	0	dBm
DC Voltage	12	VDC
Storage Temperature Range	-40 to +125	°C
Operating Temperature Range	-40 to +105	°C
Soldering Temperature (10 seconds / 5 cycles max.)	260	°C

Characteristic		Sym	Notes	Minimum	Typical	Maximum	Units
Frequency (+25 °C)	Absolute Frequency	f_C		344.950		345.050	MHz
	Tolerance from 345.0 MHz	Δf_C				±50	kHz
Insertion Loss		IL			1.4	2.2	dB
Quality Factor	Unloaded Q	Q_U			27000		
	50W Loaded Q	Q_L			4200		
Temperature Stability	Turnover Temperature	T_O		10	25	35	°C
	Turnover Frequency	f_O			f_C		
	Frequency Temperature Coefficient	FTC			0.032		ppm/°C ²
Frequency Aging	Absolute Value during the First Year	$ f_A $			10		ppm/yr
DC Insulation Resistance between Any Two Terminals				1.0			MΩ
RF Equivalent RLC Model	Motional Resistance	R_M			18		Ω
	Motional Inductance	L_M			240		μH
	Motional Capacitance	C_M			0.9		fF
	Shunt Static Capacitance	C_O			4.3		pF
Test Fixture Shunt Inductance		L_{TEST}			50		nH
Lid Symbolization: Y = Year, WW = Week, S = Shift				743, YWWS			
Standard Reel Quantity	Reel Size 7 Inch			500 Pieces / Reel			
	Reel Size 13 Inch			3000 Pieces / Reel			



CAUTION: Electrostatic Sensitive Device. Observe precautions for handling.

NOTES:

1. The design, manufacturing process, and specifications of this device are subject to change.
2. US or International patents may apply.
3. RoHS compliant from the first date of manufacture.

Electrical Connections

The SAW resonator is bidirectional and may be installed with either orientation. The two terminals are interchangeable and unnumbered. The callout NC indicates no internal connection. The NC pads assist with mechanical positioning and stability. External grounding of the NC pads is recommended to help reduce parasitic capacitance in the circuit.

Pin	Connection
1	NC
2	Terminal
3	NC
4	NC
5	Terminal
6	NC

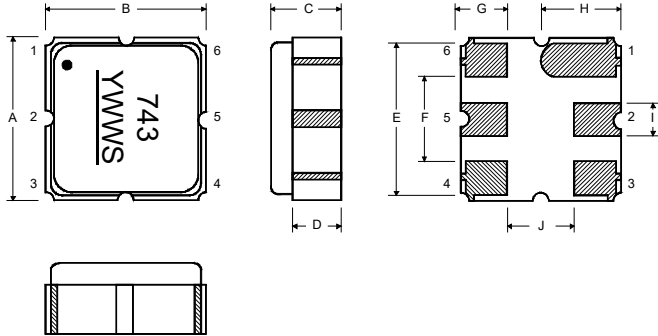

Case Dimensions

Dimension	mm			Inches		
	Min	Nom	Max	Min	Nom	Max
A	2.87	3.0	3.13	0.113	0.118	0.123
B	2.87	3.0	3.13	0.113	0.118	0.123
C	1.12	1.25	1.38	0.044	0.049	0.054
D	0.77	0.90	1.03	0.030	0.035	0.040
E	2.67	2.80	2.93	0.105	0.110	0.115
F	1.47	1.6	1.73	0.058	0.063	0.068
G	0.72	0.85	0.98	0.028	0.033	0.038
H	1.37	1.5	1.63	0.054	0.059	0.064
I	0.47	0.60	0.73	0.019	0.024	0.029
J	1.17	1.30	1.43	0.046	0.051	0.056

Typical Test Circuit

The test circuit inductor, L_{TEST} , is tuned to resonate with the static capacitance, C_O , at F_C .

Electrical Test

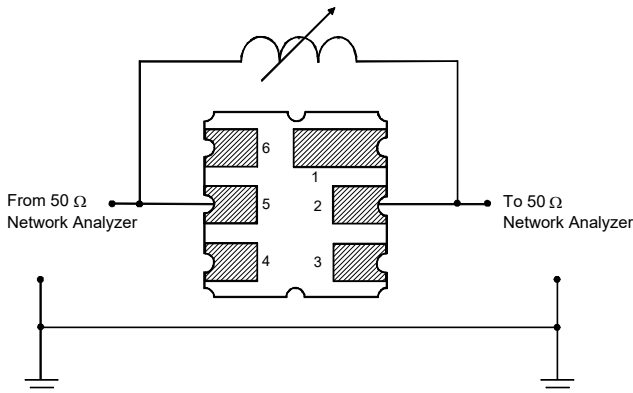

Power Test

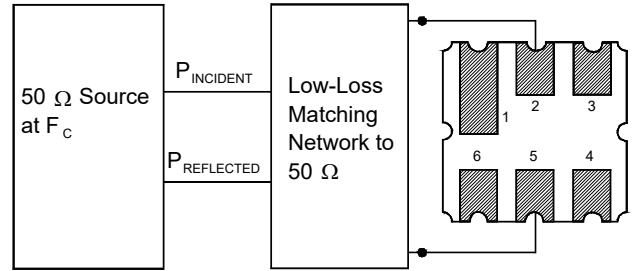

Typical Application Circuits

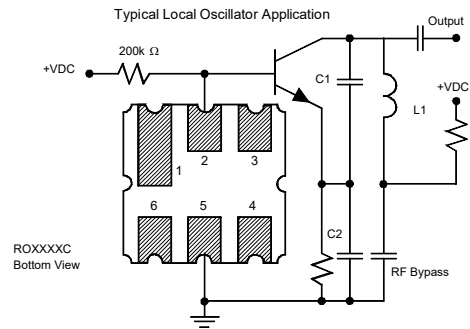
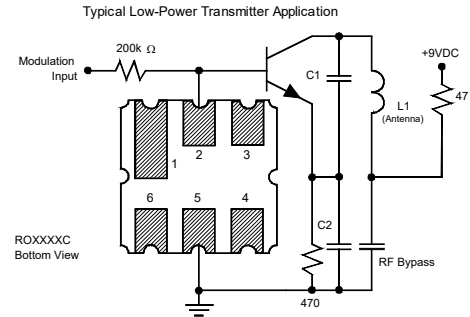

Equivalent LC Model

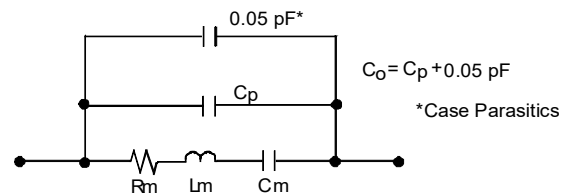

Temperature Characteristics

The curve shown on the right accounts for resonator contribution only and does not include LC component temperature contributions.

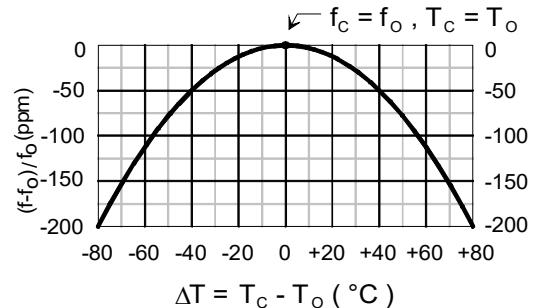

Recommended Reflow Profile

1. Preheating shall be fixed at 150~180°C for 60~90 seconds.
2. Ascending time to preheating temperature 150°C shall be 30 seconds min.
3. Heating shall be fixed at 220°C for 50~80 seconds and at 260°C +0/-5°C peak (10 seconds).
4. Time: 5 times maximum.

